



ARIOSTEA[®] GENERAL BOOK 2016

ARIOSFEA® GENERAL BOOK 2016

ARIOSTEA[®]
HIGHTECH•MARBLE•STONE & WOOD

INDEX

ARIOSTEA	4
ULTRA	16
ULTRA MARMI	34
ULTRA ONICI	66
ULTRA PIETRE	72
ULTRA RESINE	88
ULTRA ICEMENTI	90
ULTRA IRIDIUM	92
ULTRA WOOD	94
MARMI HIGH-TECH	98
PIETRE NATURALI HIGH-TECH	134
MATERIE HIGH-TECH	192
ACTIVE	212
CM2	222
LEGNI HIGH-TECH	236
WOODRAW	288
IRIDIUM	298
TECNOPORCELAIN	304
INSTALLATION	321
INFORMATION AND CODES	329
TECHNICAL FEATURES	330
CERTIFICATIONS	332
SAFE SYSTEM	336
CODES AND SIZES	338
PACKING AND WEIGHTS	360

ARIOSTEA®

MISSION & GREEN FACTORY

ARIOSTEA, DAL 1961 IL CUORE PULSANTE DELL'HIGH-TECH

Qualità assoluta, tecnologia brevettata e rispetto per l'ambiente confermano la leadership di Ariostea nella produzione di lastre compatte in gres fine porcellanato a tutto spessore.

L'unione di alta qualità ed ineguagliabile tecnologia ha portato alla reinterpretazione dei più rari, raffinati e costosi prodotti della natura, migliorandone anche le caratteristiche tecnico-qualitative e diventando in molti casi memoria storica di materiali ormai scomparsi. In questo modo Ariostea permette a chiunque di apprezzare e fruire di tutti i vantaggi dei materiali più pregiati, con l'aggiunta di straordinaria funzionalità, igiene, sicurezza e durevolezza al tempo stesso: il tutto in modo assolutamente alternativo anche dal punto di vista bio-ecologico. Una concezione nuova ed in costante rinnovamento alla ricerca di una qualità superiore della materia.

TECNOLOGIA

Le tecnologie di Ariostea sono uniche : ideate, progettate e costruite direttamente dall'azienda stessa nei propri stabilimenti, esse sono interamente (know-how, meccanica e software) tutelate con brevetti a livello internazionale. Anche le lastre in porcellanato high-tech Ariostea sono create esclusivamente con selezionatissime materie prime naturali e minerali che vengono trasformate da un processo analogo a quello della trasformazione delle rocce sulla terra nel corso dei millenni. Sottoposte a pressioni e temperature elevatissime (1300°), queste materie prime scrupolosamente ricercate in tutto il mondo danno vita ad un materiale estremamente compatto, omogeneo nell'intera massa ed inassorbente.

RESISTENZA E VERSATILITÀ

La compattezza e l'uniformità strutturale assicurano un'eccezionale resistenza all'abrasione, alla flessione, al gelo ed agli agenti chimici, consentendo l'utilizzo dei prodotti Ariostea per ogni tipo di destinazione d'uso, sia per pavimentare che per rivestire.

Dagli ambienti ad elevato calpestio alle innumerevoli applicazioni esterne (Pietre e Legni High-Tech sono le più ricercate) sino ad arrivare a contesti architettonici di altissimo pregio dove il pavimento si debba armonicamente inserire in contesti arredativi di classe assoluta.

DURABILITÀ

Le lastre Ariostea sono realizzate in massa unica, ingeliva e resistente agli attacchi chimici ed atmosferici. Esse sono pertanto garanzia di stabilità e durevolezza nel tempo, idonee a qualunque impiego e ad ogni ambiente sia interno che esterno, poiché mantengono inalterate le proprie caratteristiche tecniche ed estetiche e non necessitano di manutenzione, garantendo considerevoli risparmi di tempo ed energie.

INASSORBENZA E PULIZIA

Il coefficiente di assorbimento praticamente nullo rende i materiali high-tech Ariostea pressoché inattaccabili alle macchie e alla sporcizia, preservandone la bellezza a lungo nel tempo. Ciò rende molto più agevole, economica ed ecologica anche la cura quotidiana di un pavimento o di un rivestimento Ariostea con un evidente risparmio di tempo, di energie e di costi.



NATURA HIGH-TECH

La tecnologia Ariostea è quindi in grado di ricreare la continuità dei materiali con la storia, la cultura ed il gusto formatosi nei secoli ma ne sviluppa anche le performance (grazie alla continua innovazione), ampliandone pertanto le potenzialità applicative e le interpretazioni estetiche e tecniche in modo esponenziale.

Le caratteristiche tecniche ed estetiche delle lastre high-tech Ariostea sono uniformi in tutto lo spessore e consentono le stesse lavorazioni dei marmi, dei legni e delle pietre ornamentali valorizzando ricchezza cromatica e venature che sono uniche del nostro materiale.

COSTANZA QUALITATIVA

La gestione elettronica computerizzata del processo produttivo garantisce qualità strutturali costanti nel tempo e risultati estetici variabili in modo naturale ma controllato.

Soluzioni tecniche innovative consentono infatti di ottenere variazioni casuali delle venature e della tessitura cromatica, evitando ogni tipo di ripetitività: ciascuna lastra è diversa dalle altre, un pezzo unico, con venature uniche e che attraversano la lastra in tutto il suo spessore, esattamente come creato dalla natura.

MONOCALIBRO

Le operazioni di squadratura e di rettifica in un'unica dimensione di fabbricazione (monocalibro) a cui vengono sottoposti tutti i prodotti high-tech Ariostea, in tutte le finiture, garantiscono non solo costanza qualitativa nelle dimensioni dei prodotti forniti (facilitando notevolmente la progettazione ed il lavoro di tutti gli interessati) ma consentono anche l'abbinamento di superfici e materiali diversi.

Questa caratteristica qualitativa permette inoltre la modularità nella posa tra i numerosi formati, favorita anche dallo spessore uniforme tra i vari materiali (monospessore).

È possibile inoltre effettuare la posa con giunti molto ridotti, ottenendo risultati esteticamente sempre più gradevoli.

PERSONALIZZAZIONE

Le infinite geometrie compositive, la possibilità di creare elementi grafici con la tecnologia dell'idrogetto e dell'incisione cromatica al laser, la ricchezza di elementi ornamentali e degli infiniti pezzi speciali proposti, rendono praticamente illimitate le possibilità di personalizzazione di ogni spazio commerciale, dai più ampi e frequentati ai più raffinati ed esclusivi.



ARIOSTEA THE BEATING HEART OF CUTTING-EDGE TECHNOLOGY SINCE 1961.

Total quality, patented technology and environmental protection have assured Ariostea's leadership in the production of compact porcelain tiles in all sizes.

High quality combined with unrivalled technology has enabled us to re-interpret some of the rarest, most refined and valuable products of nature, while also enhancing their technical and qualitative properties, saving many of these materials from oblivion.

In this way, Ariostea allows you to appreciate and take full advantage of some of the most prized materials available. Other hallmarks include exceptional functionality, hygiene, safety and long-lasting durability: for what can also be seen as the perfect green, ecological alternative. The concept of the material is new and constantly being developed upon in the search for ultimate quality.

TECHNOLOGY

Ariostea's technologies are unique: they are devised, designed and implemented directly in-house at the company's own sites, and are all protected by international patents (which cover the know-how, mechanics and software).

Ariostea's high-tech porcelain tiles are made using only the choicest of natural and mineral raw materials which are subjected to a process similar to that undergone by rocks on our planet over millennia. Put to high pressure and intense heat (1300°) these raw materials, carefully researched worldwide, form a material of extreme compactness, homogeneousness and non-absorbency.

RESISTANCE AND VERSATILITY

The compactness and structural uniformity of Ariostea's products ensure their exceptional resistance to abrasion, flexure, frost and chemical agents, and therefore make them ideal for any application, whether for floors or for walls.

The tiles can be laid in areas subject to intensive use, put to a whole range of external applications (High-Tech Stone and Wood are among the most sought after) and used in architecturally impressive buildings where tiled floors have to blend gracefully in with stylish surroundings.

DURABILITY

Ariostea's tiles are solid, frost-proof and resistant to chemical and atmospheric agents. They are therefore a guarantee of stability and long-lasting durability. They are suited to any environment inside or outside as they maintain their same technical and aesthetic properties over time and do not require maintenance, saving you considerable time and energy.

NON-ABSORBENCY AND CLEANING

A virtually insignificant degree of absorbency means Ariostea's high-tech materials are practically impregnable to stains and dirt, able therefore to preserve their beauty over time.

This makes it much easier, more economical and ecological to look after an Ariostea floor or wall, saving you time, energy and expense.

HIGH-TECH NATURE

Ariosteas technology therefore recreates materials in keeping with age-old history, culture and taste, while also enhancing their performance (due to constant innovation), broadening their applicative potential and aesthetic and technical qualities on an exponential level. The technical and aesthetic properties of Ariosteas high-tech tiles are uniform throughout, ensuring consistent processing of all the marble, wood and ornamental stone. In this way we can preserve all the rich colours and veining unique to our materials.

CONSTANT QUALITY

Computerized electronic management of the production process guarantees long-lasting structural quality and control over naturally variable aesthetics.

Innovative technical solutions enable random variation in the veining and blends of colours, avoiding all repetition: each tile is unique, different from all the others, with its very own veining that courses all the way through exactly as intended by nature.

SINGLE CALIBRE

The squaring and grinding in a single manufacturing process (single calibre) to which are put all of Ariosteas high-tech products, regardless of finish, guarantee not only constant quality in terms of the finished products dimensions (vastly simplifying the design and processing of all the tiles) but also enable the combination of different surfaces and materials.

This standard of quality also permits modular installation in the many sizes, aided moreover by the uniform thickness of the various materials (single thickness).

It is also possible to lay the tiles with the thinnest of joins for a more aesthetically pleasing result.

CUSTOMIZATION

The infinite forms and shapes, the option of creating graphical elements with hydrojet and chromatic laser-cutting technology, the sheer variety of ornamental features and an endless range of special parts offer almost unlimited possibilities for customizing all commercial premises, no matter how large, busy, refined or exclusive.

ARIOSTEA SEIT 1961 DAS PULSIERENDE HERZ DER HOCHTECHNOLOGIE.

Beste Qualität, eine patentierte Technologie und Umweltschutz sichern Ariostea die Führung in der Herstellung kompakter und durchgehend gesinterter Feinsteinzeugfliesen.

Die hohe Qualität, vereint mit bester Technologie hat zu einer Neuinterpretierung der seltensten, edelsten und kostbarsten Erzeugnisse der Natur geführt und deren technische und qualitative Eigenschaften verbessert. In vielen Fällen erinnern die Produkte von Ariostea an längst verschwundene Materialien.

Auf diese Weise macht Ariostea dem Verbraucher sämtliche Vorteile der wertvollsten Materialien zugänglich, während gleichzeitig ein besonderes Augenmerk auf Funktionalität, Hygiene, Sicherheit und Haltbarkeit gelegt werden. Auch der bio-ökologische Standpunkt wird auf eine absolut alternative Weise respektiert.

Ein neues und in ständiger Erneuerung begriffenes Konzept auf der ständigen Suche nach besserer Materialqualität.

TECHNOLOGIE

Das Unternehmen Ariostea bedient sich einzigartiger Technologien: diese werden direkt in den Werken entworfen, geplant und hergestellt und sind alle (Know-how, Mechanik und Software) durch internationale Patente geschützt.

Auch die Platten aus Hightech-Steinzeug von Ariostea werden ausschließlich aus besten natürlichen Rohmaterialien und Mineralen hergestellt, die durch ein Verfahren verarbeitet werden, das analog zu dem ist, wie es die Natur im Lauf der Jahrtausende auf die Felsen ausübt. Die kostbaren, aus den verschiedensten Ländern der Erde stammenden Rohmaterialien werden sehr hohem Druck und extrem hohen Temperaturen (1300°) ausgesetzt, wodurch ein äußerst kompaktes, durchgehend gesintertertes und wasserabweisendes Material entsteht.

WIDERSTANDSFÄHIGKEIT UND VIELSEITIGKEIT

Die Kompaktheit und die strukturelle Gleichförmigkeit gewährleisten ein abriebfestes, flexibles und gegen Frost und chemische Wirkstoffe beständiges Material und ermöglichen die Anwendung der Produkte von Ariostea sowohl als Bodenbelag als auch als Wandverkleidung. Diese reicht von stark begangenen Flächen und zahllosen Außenanwendungen (High tech-Platten in Stein- und Holzoptik sind besonders begehrt) bis hin zum Einsatz in architektonischen Baukontexten von höchstem Niveau, in welche sich der Boden harmonisch in die erstklassigen Inneneinrichtungen einfügen muss.

HALTBARKEIT

Die Fliesen von Ariostea bestehen aus durchgehend gesinterter, frost- und witterungsbeständiger und gegen chemische Einflüsse beständiger Tonmasse. Sie sind zeitlos stabil und haltbar, eignen sich für vielfältige Anwendungen im Innen- wie im Außenbereich und bewahren unverändert ihre technischen und ästhetischen Eigenschaften. Sie bedürfen keiner Instandhaltung, wodurch Zeit und Energie gespart werden.

WASSERABWEISUNG UND REINIGUNG

Der Absorptionskoeffizient ist praktisch null und macht die Hightech-Materialien von Ariostea extrem beständig gegen Flecken und Schmutz, so dass sie ihre Schönheit fast zeitlos bewahren. Damit wird auch die tägliche Pflege der Böden oder der Wandverfliesungen einfacher, billiger und umweltfreundlicher und gleichzeitig werden Zeit, Energie und Kosten gespart.



HIGH TECH-NATUR

Die Technologie von Ariostea ist in der Lage, die Kontinuität der Materialien mit der Geschichte, der Kultur und dem Geschmack so wiederherzustellen, wie sie sich über die Jahrhunderte hinaus entwickelt haben, während gleichzeitig die Leistungen (dank der ständigen Innovation) und die Anwendungsmöglichkeiten sowie die ästhetischen Interpretationen exponentiell erweitert werden.

Die technischen und ästhetischen Eigenschaften der High tech-Fliesen von Ariostea sind einheitlich und durchgehend in der gesamten Fliesenmasse verteilt und ermöglichen dadurch die gleiche Verarbeitung wie bei Marmor, Holz und Zierstein. Auf diese Weise können die Farbvielfalt und die einzigartige Maserung unserer Materialien zur vollen Geltung gebracht werden.

GLEICH BLEIBENDE QUALITÄT

Die computergestützte elektronische Steuerung des Herstellungsverfahrens gewährleistet eine langfristig gleich bleibende strukturelle Qualität und ein ästhetisches, auf natürliche und kontrollierte Weise variables Ergebnis.

Die innovativen technischen Systeme machen es möglich, zufällige Variationen der Maserungen und der Farbgebung wie in der Natur zu imitieren und somit jede Art von Eintönigkeit zu vermeiden: Jede Fliese unterscheidet sich von den anderen und ist ein Einzelstück mit besonderen Maserungen, die die Fliese in ihrer ganzen Stärke durchziehen, so als hätte sie die Natur geschaffen.

EINKALIBER

Die Abvierungs- und Rektifizierungsvorgänge in einer einzigen Herstellungsgröße (Einkaliber), denen alle High tech-Produkte von Ariostea in all ihren Ausführungen unterzogen werden, gewährleisten nicht nur eine qualitative Beständigkeit bei den Abmessungen der gelieferten Produkte (wodurch die Planung und die Arbeit alle betreffenden Handwerker beträchtlich erleichtert wird), sondern gestatten auch die Kombination verschiedener Oberflächen und Materialien.

Diese Qualitätseigenschaft ermöglicht außerdem die Modularität beim Verlegen der jeweiligen zahlreichen Formate. Dies wird auch durch die einheitliche Stärke der verschiedenen Materialien begünstigt (nur eine Stärke).

Dadurch kann das Verlegen mit sehr kleinen Fugen ausgeführt werden, wodurch sehr ästhetische Resultate erzielt werden.

INDIVIDUELLE GESTALTUNG

Die unendlichen kompositorischen Geometrien, die Möglichkeit, mittels der Wasserstrahltechnik und dem chromatischen Laserschnitt graphische Elemente zu schaffen, der Reichtum an ornamentalen Elementen und das unendliche Angebot von Sonderstücken, machen die Möglichkeiten für die individuelle Gestaltung jedes kommerziellen Bereichs praktisch unbegrenzt. Sie eignen sich daher gleichermaßen für große und häufig begangene wie für vornehme und exklusive Räumlichkeiten.



ARIOSTEA LE COEUR DE LA HAUTE-TECHNOLOGIE DEPUIS 1961.

Qualité absolue, technologie brevetée et respect de l'environnement, confèrent à Ariostea une place de leader dans la production de dalles compactes en grès fin porcelainé, toutes épaisseurs. L'association d'une très grande qualité et d'une technologie unique ont permis de réinterpréter les produits de la nature les plus rares, les plus raffinés et les plus coûteux, en améliorant également leurs caractéristiques techniques et leur qualité et en devenant dans de nombreux cas la mémoire historique de matériaux désormais disparus.

De cette façon, Ariostea permet à chacun d'apprécier et d'exploiter tous les avantages des matériaux les plus appréciés en leur apportant des fonctionnalités extraordinaires en matière d'hygiène, de sécurité et de durabilité réunies en un seul matériau : le tout de façon totalement alternative, y compris du point de vue bioécologique.

Une conception nouvelle qui se renouvelle constamment en quête d'une qualité supérieure de la matière.

TECHNOLOGIE

Les technologies d'Ariostea sont uniques : conçues, développées et mises au point par l'entreprise, dans ses propres locaux, et intégralement protégées (savoir-faire, mécanique et logiciel) par des brevets reconnus au niveau international.

Même les dalles porcelainées de haute-technologie d'Ariostea sont créées exclusivement avec des matières premières naturelles et minérales faisant l'objet d'une sélection rigoureuse qui sont transformées au terme d'un processus analogue à celui de la transformation des roches sur la terre au fil des millénaires.

Soumises à des pressions et à des températures très élevées (1300°C), ces matières premières scrupuleusement recherchées dans le monde entier donnent vie à un matériau extrêmement compact, homogène dans la masse et imperméable.

RÉSISTANCE ET POLYVALENCE

La nature compacte et l'uniformité structurelle assurent une résistance exceptionnelle à l'abrasion, à la flexion, au gel et aux agents chimiques. Ils permettent l'utilisation des produits Ariostea dans des contextes variés, qu'il s'agisse de paver ou de revêtir.

Ces dalles sont adaptées à une gamme étendue d'utilisations allant des environnements soumis à un piétinement important, aux infinies applications en extérieur (les pierres et le bois high-tech sont les plus recherchés), en passant par des contextes architectoniques de très grande valeur où le revêtement de sol doit être en parfaite harmonie avec un mobilier luxueux.

DURABILITÉ

Les dalles Ariostea sont réalisées en une unique masse, ingélive et résistante aux attaques chimiques et atmosphériques. Leur stabilité et leur durabilité est garantie dans le temps. Elles sont idéales quel que soit leur emploi et le type d'environnement intérieur ou extérieur puisqu'elles conservent leurs caractéristiques techniques et esthétiques et ne nécessitent aucun entretien particulier. Outre un véritable gain de temps, elles permettent de réaliser d'importantes économies d'énergie.



IMPERMÉABILITE ET PROPRETÉ

Le coefficient d'absorption pratiquement nul rend les matériaux high-tech Ariosteas quasiment imperméables aux tâches et à la saleté ; il en préserve la beauté au fil du temps.

Ceci permet un entretien journalier plus facile, économique et écologique du revêtement de sol Ariosteas et de réaliser des économies substantielles en termes de temps, d'énergie et d'argent.

NATURE HIGH-TECH

La technologie Ariosteas est donc capable de renouer avec la continuité des matériaux dans l'histoire, la culture et le goût qui s'est développé au fil des siècles. Mais elle en optimise également les performances (grâce à l'innovation continue), en développant les potentialités d'application, les interprétations esthétiques et techniques de façon exponentielle.

Les caractéristiques techniques et esthétiques des dalles high-tech Ariosteas sont uniformes, quelle que soit l'épaisseur choisie. Elles permettent les mêmes transformations des marbres, des bois et des pierres ornementales dont elles mettent en valeur la richesse chromatique et le veinage unique de notre matériau.

CONSTANCE QUALITATIVE

La gestion électronique informatisée du processus de production garantit des qualités structurelles constantes dans le temps. Les résultats esthétiques varient de façon naturelle, mais contrôlée.

Les solutions techniques innovantes permettent en fait d'obtenir des variations aléatoires des veines et de la tessiture chromatique,

en évitant tout type de répétitivité : chaque dalle est différente des autres. C'est une pièce unique, avec un veinage unique qui traverse la dalle dans toute son épaisseur, exactement comme ce qui a été créé par la nature.

MONOCALIBRE

Les opérations d'équerrage et de rectification dans une dimension unique de fabrication (monocalibre) auxquelles sont soumis les produits high-tech d'Ariosteas, quelle que soit leur finition, garantissent non seulement une constance qualitative dans les dimensions des produits fournis (en facilitant considérablement la conception et le travail de toutes les personnes impliquées), mais permettent également d'associer des surfaces et des matériaux différents.

Cette caractéristique qualitative permet en outre la modularité dans la pose, entre les différents formats disponibles. Elle bénéficie également de l'épaisseur uniforme entre les différents matériaux (monoépaisseur).

Par ailleurs, la pose est réalisable avec des joints très fins, ce qui permet d'obtenir, sur le plan esthétique, des résultats très appréciés.

PERSONNALISATION

Les compositions géométriques infinies, la possibilité de créer des éléments graphiques grâce à la technologie de l'hydrojet et de l'incision chromatique au laser, la richesse des éléments ornementaux et du très grand nombre de pièces spéciales proposées, font que les possibilités de personnalisation de chaque espace commercial, des plus vastes et fréquentés aux plus raffinés et exclusifs, sont presque illimitées.

ARIOSTEAGREENROOM

Progettare il GreenRoom è stata per me l'occasione di sperimentare nuove applicazioni delle grandi superfici ceramiche che la tecnologia Ultra offre e di studiare l'incontro tra materiali lontani come vetro e ceramica.

L'area dedicata allo showroom, spogliata delle superfetazioni del passato, si è presentata nella sua forma più semplice in cui una grande quantità di situazioni strutturali differenti hanno fornito la grammatica essenziale per un nuovo linguaggio di geometrie e volumi.

Al fine di creare una stimolante esperienza espositiva e di ricavare spazi in equilibrio e continuità tra loro, ho sfruttato la moltitudine di pilastri presenti nelle due ali del palazzo inscrivendoli in portali di superfici variabili. Attraverso il loro susseguirsi ogni area tematica si mantiene in contatto

con il progetto nel suo insieme. I due anonimi porticati che affiancavano i percorsi principali, una volta ricongiunti al volume interno, sono stati trasformati in cannocchiali espositivi con la duplice funzione di filtro e collegamento visivo con il garden esterno.

In considerazione della genesi simmetrica dell'edificio e delle aree adiacenti, ho trovato opportuno trasporre il concetto di incontro anche nel grande salone centrale dove è stato collocato l'ingresso principale, oltrepassato il quale si intuisce immediatamente lo sviluppo dei due rami che qui confluiscono dando origine ad una scenografia frontale in cui il contatto tra natura e materia trova la sua massima espressione, fondendo la luce naturale e quella artificiale.

Architetto Marco Porpora



Design the Greenroom was the opportunity for me to experiment new applications of large ceramic surfaces offered by Ultra technology and to study the encounter between different materials as glass and ceramics. The showroom area, deprived of past traces, in its simplest structure, with a large amount of different structural situations, provided the essential grammar for a new language of shapes and volumes. In order to create an inspiring exhibition experience and to protect areas equilibrium and continuity, I took advantage of the two wings pillar multitude of the building inscribing them into variable surface gates. Each thematic area, through this sequence, keep connection with the

whole project.

Two anonymous colonnades following the main routes, once rejoined to the internal volume, have been turned into exhibition telescopes with the dual function of filtering and visually relating the outside garden. In consideration of the building and adjacent areas symmetrical genesis, I've wanted to transpose the encounter concept even in the wide central room where is placed the main entrance, beyond which is immediately perceptible the beginning of two route branches that come together here to create a frontal stage where nature and material contact is in its highest expression, melting natural and artificial light.

Architect Marco Porpora







ARIOSTEAGREENROOM



Ci sono momenti tecnologici in cui un prodotto segna il passo allo stato della tecnica modificando il nostro stile di vita. È stato così con l'avvento dell'automobile, della televisione, di internet o degli smartphone per esempio. Crediamo che ragionevolmente ed egualmente si possa guardare, con simile ammirazione, al salto tecnologico che ha consentito al settore ceramico di passare dai formati tradizionali a quelli giganti che contraddistinguono il progetto Ultra. La scala di grandezza dei materiali supera ora ampiamente i riferimenti antropometrici del Modulor teorizzato da Le Corbusier nel 1948, toccando i 3 metri di altezza e rapportandosi non più solo al fattore umano ma all'edificio nel suo complesso, consentendone la risoluzione dell'interfaccia esterna oltre alla vestizione degli spazi interni.

There are technological moments in which a product makes the leap to being state of the art and changes our life style. For example, it was so for the automobile, the television, the Internet and smartphones. We feel that you could reasonably and equally look, with similar admiration, to the technological leap that has allowed the ceramic sector to move on from its traditional sizes to giant ones, like those that distinguish the Ultra project. The scale of proportions is now far larger than the anthropometric reference points of the Modulor originally theorized by Le Corbusier in 1948. These reach 3 metres in height and relate not only to just the human factor, but to the building in its entirety allowing the resolution of the external interface as well as the dressing of the internal spaces.



ULTRA[®]

ARIOSTEA[®]HIGHTECH



Es gibt Momente, in denen ein Produkt der modernen Technik weicht und so unseren Lebensstil verändert.

Dies war ganz eklatant der Fall, als das Automobil, der Fernseher, Internet oder die modernen Smartphones erfunden wurden.

Wir sind der Meinung, dass man auf gleiche Weise und mit fast ähnlicher Bewunderung den technischen Fortschritt betrachten kann, der es der Keramikindustrie ermöglicht hat, von den traditionellen Größen zu den gigantischen und großformatigen Platten zu wechseln, die unser Projekt Ultra auszeichnen. Die Größenordnung des Materials überragt bei Weitem das anthropometrische Proportions-System des von Le Corbusier im Jahr 1948 theoretisierten Modulors und passt sich mit seinen 3 Metern Höhe nicht nur dem Faktor Mensch an, sondern auch dem gesamten Gebäudekomplex, wodurch eine Auflösung der externen Schnittstelle ermöglicht wird, die weit über die einfache Verkleidung des Innenraums hinausgeht.

Il existe des moments technologiques où le produit marque le pas sur l'état de la technique, en modifiant notre style de vie.

C'est ce qui est arrivé avec l'avènement de l'automobile, de la télévision, d'Internet ou des smartphones, par exemple.

Nous pensons qu'il est possible d'étudier de manière raisonnable et égale, mais aussi avec une admiration semblable, les progrès technologiques qui ont permis au secteur de la céramique de passer des formats traditionnels aux formats immenses qui distinguent le projet Ultra. L'échelle de grandeur des matériaux dépasse désormais largement les références anthropométriques du Modulor théorisé par Le Corbusier en 1948, atteignant 3 mètres de hauteur et se rapportant non plus seulement au facteur humain, mais au bâtiment dans son intégralité, permettant la résolution de l'interface externe, ainsi que l'habillage des espaces internes.

6_{mm} THICKNESS

10_{mm} THICKNESS

7 COLLECTIONS

4 FINISHES

ULTRA[®]

ARIOSTEA[®] HIGHTECH

320 X 160

300 X 150

300 X 100

320x160
128" x 64"

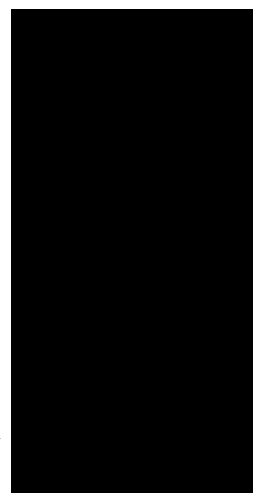

160x160
64" x 64"

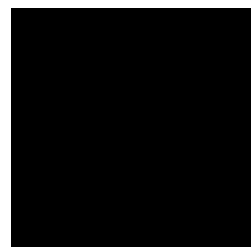

300x150
120" x 60"



150x150
60" x 60"



150x100
60" x 40"



150x75
60" x 30"

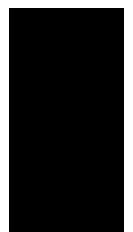

BIGGEST

ULTRA con i suoi 5,12 m² è il nuovo punto di riferimento per i progettisti e per tutti gli interventi dove le dimensioni fanno la differenza.

With its area of 5,12 m², ULTRA is the new industry standard for project designers and for all projects where dimensions make the difference.

Mit seinen 5,12 m² ist ULTRA die neue Bezugsgröße für die Gestalter und für alle Gelegenheiten, bei denen die Maße den Unterschied bilden.

ULTRA et ses 5,12 m² est un nouveau point de référence pour les concepteurs et dans toutes les interventions où les dimensions font la différence.

LIGHTEST

ULTRA con il suo spessore 6 mm nativo, garantisce leggerezza e resistenza per tutte le applicazioni, anche quelle a cui non avevi pensato.

Thanks to its native 6 mm thickness, ULTRA provides lightness and strength in all applications - even the ones you'd never even imagined.

Mit seiner ursprünglichen Dicke von 6 mm garantiert ULTRA leichtes Gewicht und Widerstandsfähigkeit für alle Anwendungen, auch solchen, an die Sie vielleicht nicht gedacht haben.

ULTRA, aux épaisseurs de 6 mm à l'état natif, est un gage de légèreté et de résistance pour toutes les applications, même celles auxquelles vous n'aviez pas pensé.

TAILORED

ULTRA offre estrema flessibilità al progetto e la libertà di realizzare le tue idee senza vincoli di formato.

ULTRA offers unmatched project flexibility and the freedom to give concrete form to your ideas without being shackled by size.

ULTRA bietet höchste Flexibilität der Gestaltung und die Freiheit, Ideen zu entwickeln, ohne durch das Format eingeschränkt zu sein.

ULTRA offre une grande polyvalence dans la création de projet ainsi que la liberté de réaliser vos idées sans contraintes de format.

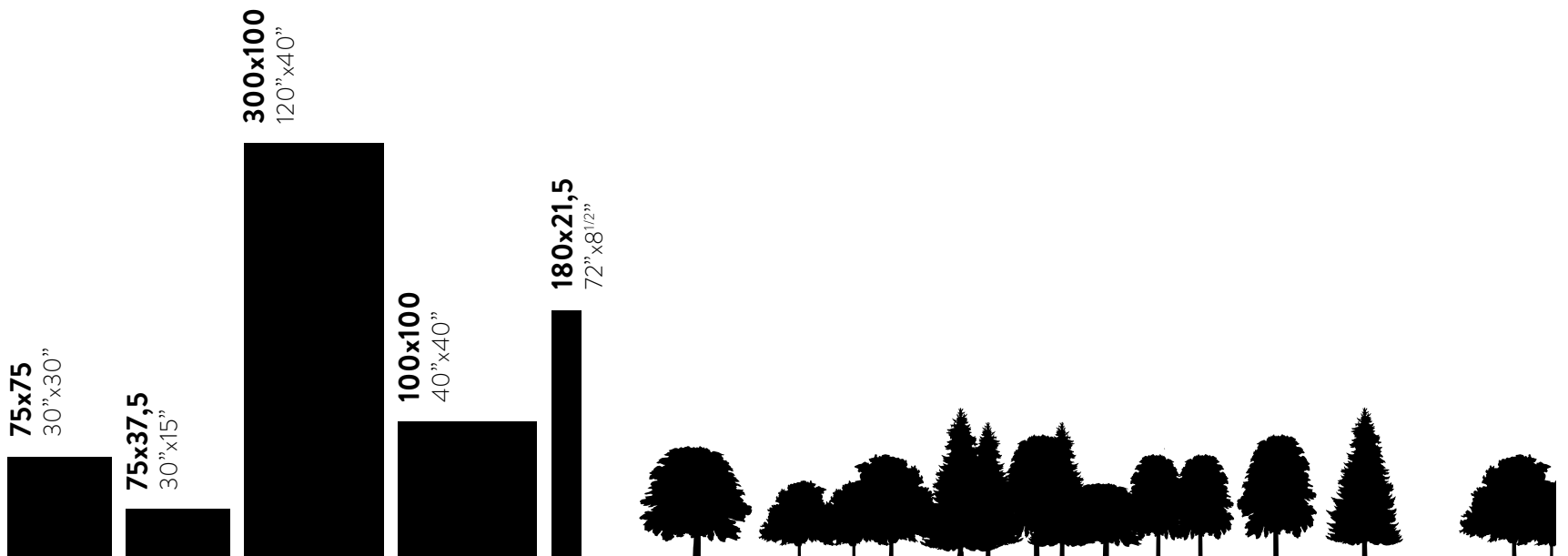

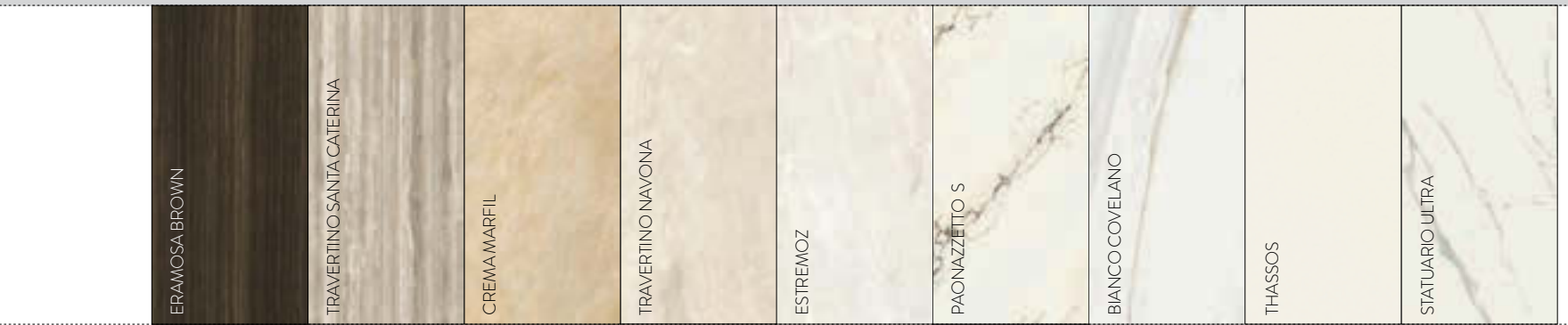

ULTRA ONICI
 soft/shiny



ULTRA iCementi
 soft

180X21,5 cm

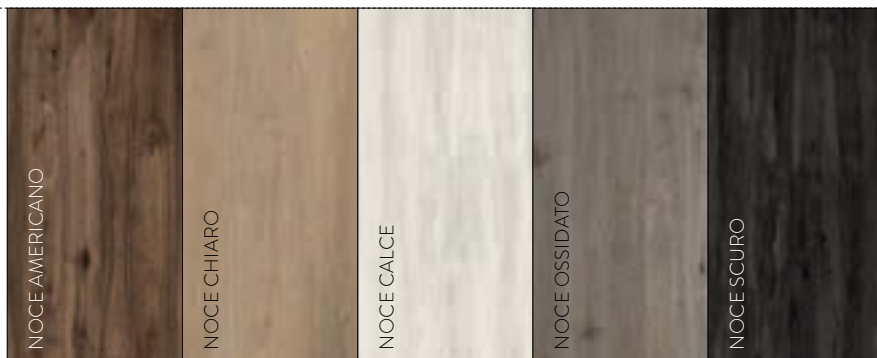

ULTRA WOOD
 soft

METRO

ULTRA TECHNOLOGY by ARIOSTEA HIGH-TECH

300 X 100

100 X 100

STATUARIO ALTISSIMO

ARABESCATO STATUARIO

GRIS DE SAVOIE

ZEBRINO BLACK

CREMA MARFIL

THASSOS

ULTRA MARMI
soft/shiny

BIANCO

GRIGIO

NERO

BIANCO

NERO

ULTRA IRIDIUM
soft/shiny

GRAPHITE

IRON

SILVER

IVORY

ULTRA Pietre
soft/structured/prelucidato

JERUSALEM LIMESTONE

AZUL BATEIG LIMESTONE

SAN VICENTE LIMESTONE

BASALTINA ANTRACITE

BASALTINA GREY

BASALTINA WHITE

BASALTINA SAND

BASALTINA MOKA

ULTRA Resine
soft/prelucidato

CALCE

SILICIO

PIOMBO

EBANO

300X150 cm

300X100 cm



T H I C K N E S S

6/10_{mm}

Per rendere la tecnologia Ultra sempre più flessibile e adattabile alle diverse esigenze applicative, tutte le collezioni basate sui formati nativi 320 x 160, 300 x 150, 300 x 100 cm sono disponibili con spessore 6 mm e a richiesta 10 mm.

To make Ultra technology more and more flexible and adaptable to different application needs, all the collections based on the native sizes of 320 x 160, 300 x 150, 300 x 100 cm are available with a thickness of 6 mm and on request also 10 mm.

Um die Ultra-Technologie stets flexibler gestalten und besser an die unterschiedlichsten Verwendungszwecke anpassen zu können, sind alle Produkte aus der Kollektion in den standardmäßigen Größenformaten 320 x 160, 300 x 150, 300 x 100 cm erhältlich, die mit einer Stärke von 6 mm und auf Wunsch 10 mm erhältlich sind.

Pour rendre la technologie Ultra de plus en plus flexible et adaptable aux besoins des différentes applications, toutes les collections basées sur des formats traditionnels 320 x 160, 300 x 150, 300 x 100 cm sont disponibles avec une épaisseur 6 mm et sur demande 10 mm.



F I N I S H E S



SHINY

SOFT

STRUCTURED

PRELUCIDATO



APPLICATIONS



LARGE FIELDS OF APPLICATION

The flexibility of ULTRA technology allows the various product collections developed by Ariostea to be completely adapted to generate projects ranging from simple flooring or coverings for large or small surfaces to object-based applications and furnishing accessories.

Using this new concept that combines light weight and technical performance, it is now possible to create genuine products or installations with the added benefits that come with ceramic technology. The very nature of the material also lets designers apply each of these possibilities in indoor and outdoor environments to develop smooth, curved and even backlit surfaces.

La duttilità della tecnologia ULTRA consente di adattare le varie collezioni di prodotti sviluppate da Ariostea generando progetti che spaziano dal semplice pavimento o rivestimento di piccole e grandi superfici, all'applicazione su oggetti e complementi d'arredo.

Realizzare veri e propri manufatti o installazioni con un nuovo concetto di leggerezza e prestazione tecnica coniugata è ora possibile avendo accesso anche alle prestazioni superiore date dalla tecnologia ceramica. La natura stessa del materiale consente inoltre al progettista di declinare ognuna di queste possibilità in ambienti interni ed esterni sviluppando superfici omogenee, curve e anche retroilluminate.



**FLOORS &
WALLS**



**TOPS &
BATHROOMS**

A vertical photograph showing a dark, vertically-grained wood wall. In the foreground, a white, rectangular table with a marble top is partially visible. The floor is a light-colored, neutral tone.

**INTERIOR
DECORATION
& DESIGN**

A vertical photograph of a white marble door with a sliding mechanism. The marble has a pattern of grey and gold veins. A black handle and a small circular detail are visible on the right side of the door.

**DOORS &
SLIDING
WALLS**

A vertical photograph of a curved wall with a white marble pattern featuring blue and grey veins. A white modern chair with a black metal base is positioned in the foreground. The floor is a light, reflective surface.

**CURVED
WALLS**



VENTILATED FAÇADE

SAFETY CLIP SYSTEM
WET ENVELOPES

SISTEMA SAFETY CLIP
INVOLUCRO A UMIDO



THERMAL CLADDING SYSTEM
WET ENVELOPES

SISTEMA A CAPPOTTO
INVOLUCRO A UMIDO



MICRO SYSTEM
DRY ENVELOPES

SISTEMA MICRO
INVOLUCRO A SECCO



VENTILATED FAÇADE
DRY ENVELOPES

FACCIATA VENTILATA
INVOLUCRO A SECCO



ULTRA FRAME SYSTEM
DRY ENVELOPES

SISTEMA ULTRA FRAME
INVOLUCRO A SECCO



ULTRA LIGHT SYSTEM
DRY ENVELOPES

SISTEMA ULTRA LIGHT
INVOLUCRO A SECCO



BACKLIGHT





The extremely reduced 6mm thickness, together with the advanced Ultra technology, allows an appropriately powerful band of light to travel through the Ultra slabs and backlight the material.

Lo spessore estremamente contenuto di 6 mm insieme all'evoluta tecnologia consentono ad alcuni prodotti Ultra di poter essere attraversate da un fascio luminoso di adeguata potenza ottenendo la retroilluminazione del materiale.

ULTRA[®]

ARIOSTEA[®] HIGHTECH

MARMI

RETTIFICATO MONOCALIBRO

RECTIFIED SINGLE-CALIBRE /
REKTIFIZIERT EINKALIBRIG /
RECTIFIÉ MONOCALIBRE

SPESSORE

THICKNESS / DICKE / ÉPAISSEUR

▼
6mm
▲

FORMATI

SIZES / FORMATE / FORMATS

150 x 150 cm

60" x 60"

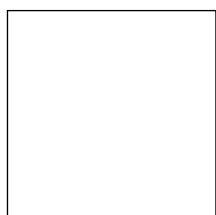

150 x 75 cm

60" x 30"



75 x 75 cm

30" x 30"

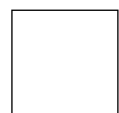

75 x 37,5 cm

30" x 15"



SUPERFICI / SURFACES / OBERFLÄCHEN / SURFACES

SHINY

SOFT

FORMATI pag. 338

SIZES pag. 338 / FORMATE pag. 338 / FORMATS pag. 338



ARABESCATO STATUARIO



ULTRA[®]

ARIOSTEA[®] HIGHTECH

MARMI

.....

RETTIFICATO MONOCALIBRO

RECTIFIED SINGLE-CALIBRE /
REKTIFIZIERT EINKALIBRIG /
RECTIFIÉ MONOCALIBRE

SPESSORE

THICKNESS / DICKE / ÉPAISSEUR

▼
6mm
▲

FORMATI

SIZES / FORMATE / FORMATS

300 x 150 cm

120" x 60"

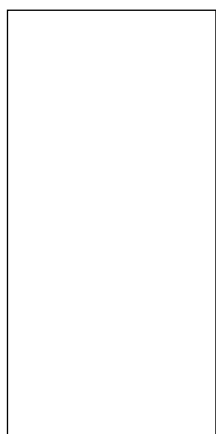

SUPERFICI / SURFACES /
OBERFLÄCHEN / SURFACES

SHINY
SOFT

FORMATI pag. 338

SIZES pag. 338 / FORMATE pag. 338 / FORMATS pag. 338

300 X 150

ARABESCATO STATUARIO BLOCK A

BOOKMATCH

ARABESCATO
STATUARIO
BLOCK B

ULTRA[®]

ARIOSTEA[®] HIGHTECH

MARMI

RETTIFICATO MONOCALIBRO

RECTIFIED SINGLE-CALIBRE /
REKTIFIZIERT EINKALIBRIG /
RECTIFIÉ MONOCALIBRE

SPESSORE

THICKNESS / DICKE / ÉPAISSEUR

▼
6mm
▲

FORMATI

SIZES / FORMATE / FORMATS

300 x 150 cm

120" x 60"

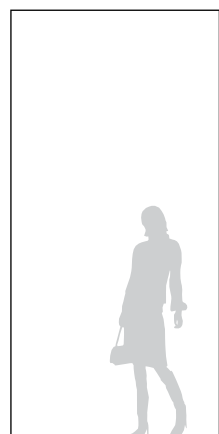

300 x 100 cm

120" x 40"

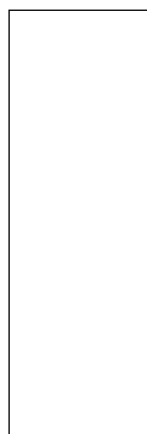

150 x 150 cm

60" x 60"



150 x 100 cm

60" x 40"

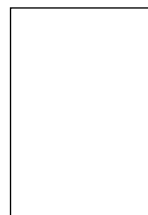

150 x 75 cm

60" x 30"

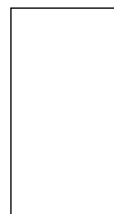

100 x 100 cm

40" x 40"

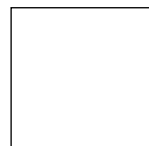

75 x 75 cm

30" x 30"

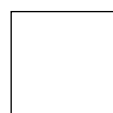

75 x 37,5 cm

30" x 15"



SUPERFICI / SURFACES / OBERFLÄCHEN / SURFACES

SHINY

SOFT

FORMATI pag. 338

SIZES pag. 338 / FORMATE pag. 338 / FORMATS pag. 338

300 X 150

THASSOS

ULTRA[®]

ARIOSTEA[®] HIGHTECH

MARMI

RETTIFICATO MONOCALIBRO

RECTIFIED SINGLE-CALIBRE /
REKTIFIZIERT EINKALIBRIG /
RECTIFIÉ MONOCALIBRE

SPESSORE

THICKNESS / DICKE / ÉPAISSEUR

▼
6mm
▲

FORMATI

SIZES / FORMATE / FORMATS

300 x 150 cm

120" x 60"

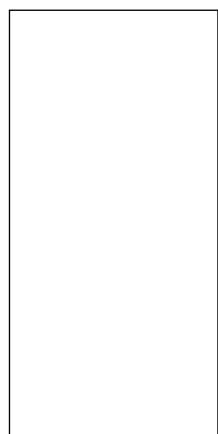

150 x 150 cm

60" x 60"



150 x 75 cm

60" x 30"

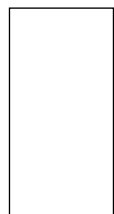

75 x 75 cm

30" x 30"

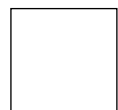

75 x 37,5 cm

30" x 15"



SUPERFICI / SURFACES / OBERFLÄCHEN / SURFACES

SHINY

SOFT

FORMATI pag. 338

SIZES pag. 338 / FORMATE pag. 338 / FORMATS pag. 338

300X150



STATUARIO ALTISSIMO



ULTRA[®]

ARIOSTEA[®] HIGHTECH

MARMI

.....

RETTIFICATO MONOCALIBRO

RECTIFIED SINGLE-CALIBRE /
REKTIFIZIERT EINKALIBRIG /
RECTIFIÉ MONOCALIBRE

SPESSORE

THICKNESS / DICKE / ÉPAISSEUR

▼
6mm
▲

FORMATI

SIZES / FORMATE / FORMATS

300 x 150 cm

120" x 60"

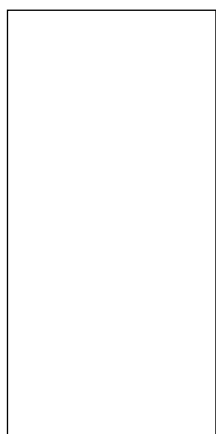

**SUPERFICI / SURFACES /
OBERFLÄCHEN / SURFACES**

**SHINY
SOFT**

FORMATI pag. 338

SIZES pag. 338 / FORMATE pag. 338 / FORMATS pag. 338

300 X 150

STATUARIO ALTISSIMO BLOCK A

BOOKMATCH

STATUARIO
ALTISSIMO
BLOCK B

ULTRA®

ARIOSFEA® HIGHTECH

MARMI

RETTIFICATO MONOCALIBRO

RECTIFIED SINGLE-CALIBRE /
REKTIFIZIERT EINKALIBRIG /
RECTIFIÉ MONOCALIBRE

SPESSORE

THICKNESS / DICKE / ÉPAISSEUR

▼
6mm
▲

FORMATI

SIZES / FORMATE / FORMATS

300 x 150 cm

120" x 60"

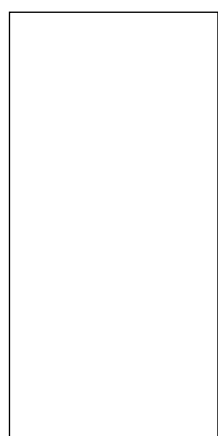

150 x 150 cm

60" x 60"



150 x 75 cm

60" x 30"



75 x 75 cm

30" x 30"

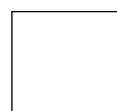

75 x 37,5 cm

30" x 15"



300 X 150

SUPERFICI / SURFACES / OBERFLÄCHEN / SURFACES

SHINY

SOFT

FORMATI pag. 338

SIZES pag. 338 / FORMATE pag. 338 / FORMATS pag. 338

BIANCO COVELANO



ULTRA[®]

ARIOSFEA[®] HIGHTECH

MARMI

.....

RETTIFICATO MONOCALIBRO

RECTIFIED SINGLE-CALIBRE /
REKTIFIZIERT EINKALIBRIG /
RECTIFIÉ MONOCALIBRE

SPESSORE

THICKNESS / DICKE / ÉPAISSEUR

▼
6mm
▲

FORMATI

SIZES / FORMATE / FORMATS

300 x 150 cm

120" x 60"

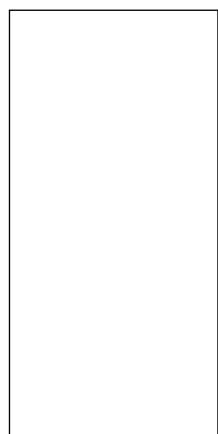

150 x 150 cm

60" x 60"



150 x 75 cm

60" x 30"



75 x 75 cm

30" x 30"



75 x 37,5 cm

30" x 15"



SUPERFICI / SURFACES / OBERFLÄCHEN / SURFACES

SHINY

SOFT

FORMATI pag. 338

SIZES pag. 338 / FORMATE pag. 338 / FORMATS pag. 338

300 X 150

ESTREMOZ



ULTRA[®]

ARIOSFEA[®] HIGHTECH

MARMI

RETTIFICATO MONOCALIBRO

RECTIFIED SINGLE-CALIBRE /
REKTIFIZIERT EINKALIBRIG /
RECTIFIÉ MONOCALIBRE

SPESSORE

THICKNESS / DICKE / ÉPAISSEUR

▼
6mm
▲

FORMATI

SIZES / FORMATE / FORMATS

300 x 150 cm

120" x 60"

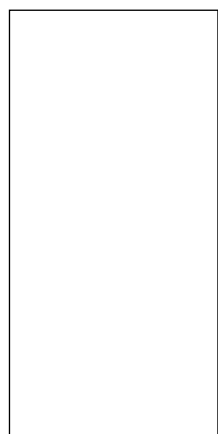

150 x 150 cm

60" x 60"



150 x 75 cm

60" x 30"



75 x 75 cm

30" x 30"

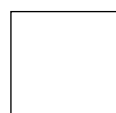

75 x 37,5 cm

30" x 15"



SUPERFICI / SURFACES / OBERFLÄCHEN / SURFACES

SHINY

SOFT

FORMATI pag. 338

SIZES pag. 338 / FORMATE pag. 338 / FORMATS pag. 338

300X150

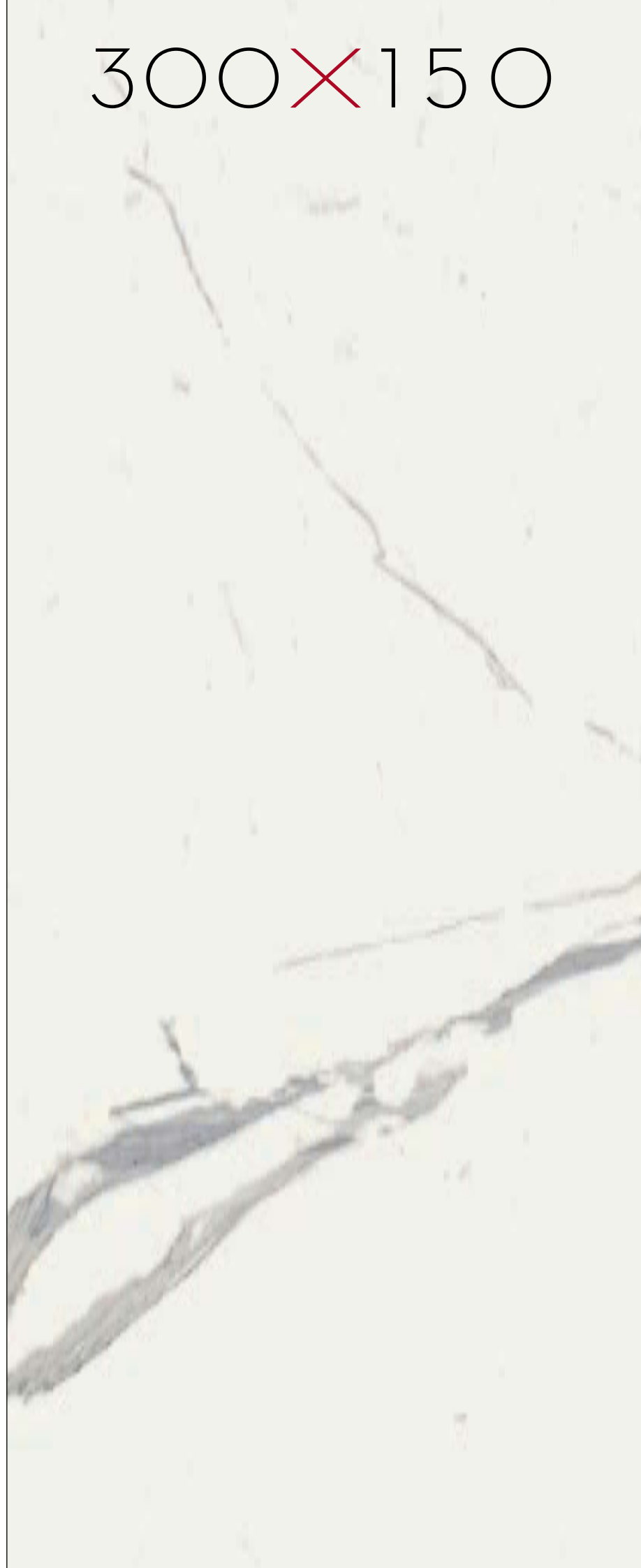

STATUARIO ULTRA



ULTRA[®]

ARIOSTEA[®] HIGHTECH

MARMI

.....

RETTIFICATO MONOCALIBRO

RECTIFIED SINGLE-CALIBRE /
REKTIFIZIERT EINKALIBRIG /
RECTIFIÉ MONOCALIBRE

SPESSORE

THICKNESS / DICKE / ÉPAISSEUR

▼
6mm
▲

FORMATI

SIZES / FORMATE / FORMATS

300 x 150 cm

120" x 60"

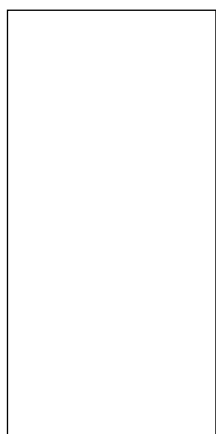

SUPERFICI / SURFACES /
OBERFLÄCHEN / SURFACES

SHINY
SOFT

FORMATI pag. 338

SIZES pag. 338 / FORMATE pag. 338 / FORMATS pag. 338

300 X 150

STATUARIO ULTRA BLOCK A



BOOKMATCH

STATUARIO
ULTRA
BLOCK B

ULTRA[®]

ARIOSTEA[®] HIGHTECH

MARMI

RETTIFICATO MONOCALIBRO

RECTIFIED SINGLE-CALIBRE /
REKTIFIZIERT EINKALIBRIG /
RECTIFIÉ MONOCALIBRE

SPESSORE

THICKNESS / DICKE / ÉPAISSEUR

▼
6mm
▲

FORMATI

SIZES / FORMATE / FORMATS

300 x 150 cm

120" x 60"

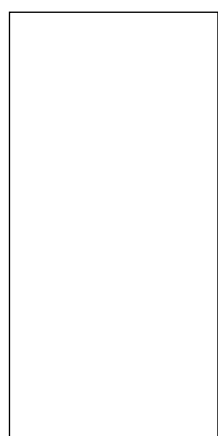

150 x 150 cm

60" x 60"



150 x 75 cm

60" x 30"

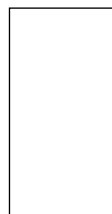

75 x 75 cm

30" x 30"

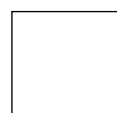

75 x 37,5 cm

30" x 15"



SUPERFICI / SURFACES / OBERFLÄCHEN / SURFACES

SHINY

SOFT

FORMATI pag. 338

SIZES pag. 338 / FORMATE pag. 338 / FORMATS pag. 338

300 X 150

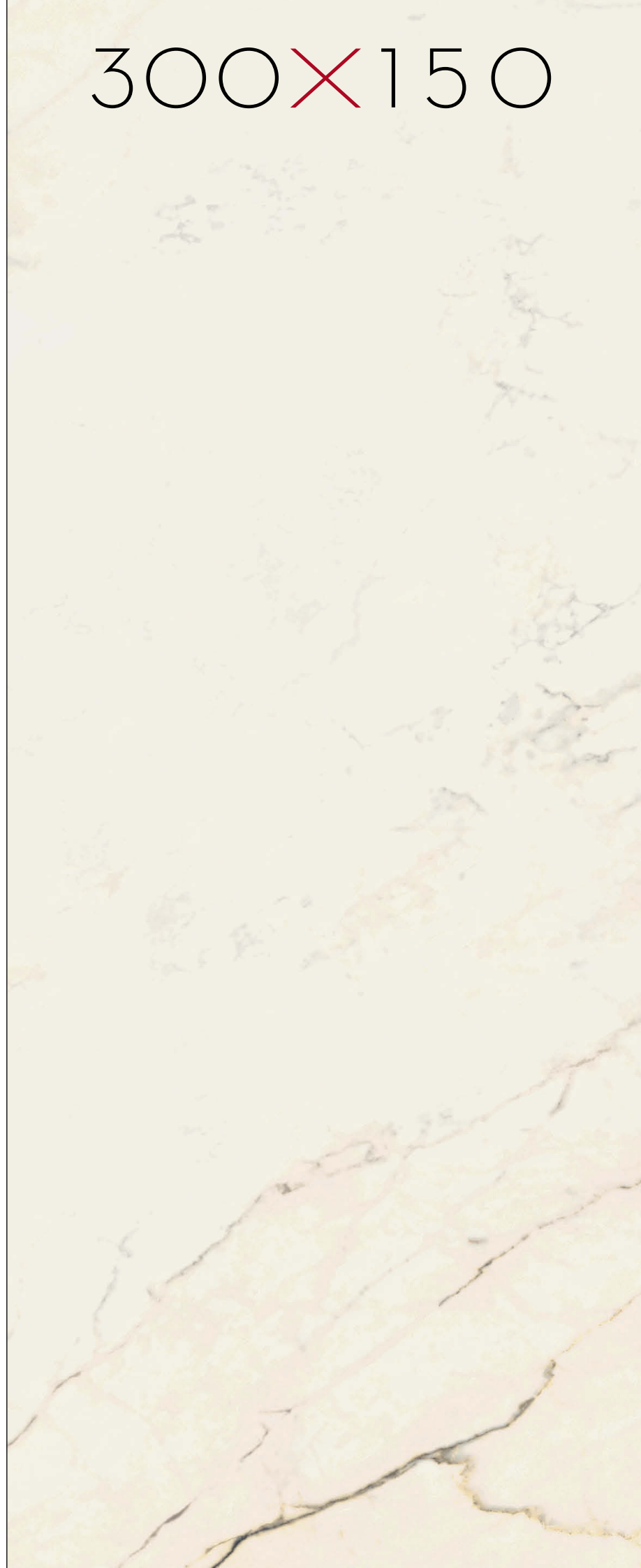



ULTRA®

ARIOSTEA® HIGHTECH

MARMI

RETTIFICATO MONOCALIBRO

RECTIFIED SINGLE-CALIBRE /
REKTIFIZIERT EINKALIBRIG /
RECTIFIÉ MONOCALIBRE

SPESSORE

THICKNESS / DICKE / ÉPAISSEUR

▼
6mm
▲

FORMATI

SIZES / FORMATE / FORMATS

300 x 150 cm

120" x 60"

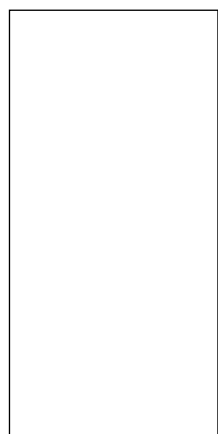

150 x 150 cm

60" x 60"

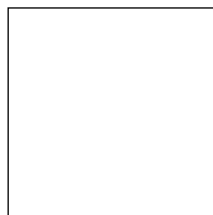

150 x 75 cm

60" x 30"



75 x 75 cm

30" x 30"

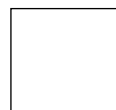

75 x 37,5 cm

30" x 15"



300 X 150

SUPERFICI / SURFACES / OBERFLÄCHEN / SURFACES

SHINY

SOFT

FORMATI pag. 338

SIZES pag. 338 / FORMATE pag. 338 / FORMATS pag. 338

TRAVERTINO NAVONA



ULTRA[®]

ARIOSTEA[®] HIGHTECH

MARMI

RETTIFICATO MONOCALIBRO

RECTIFIED SINGLE-CALIBRE /
REKTIFIZIERT EINKALIBRIG /
RECTIFIÉ MONOCALIBRE

SPESSORE

THICKNESS / DICKE / ÉPAISSEUR

▼
6mm
▲

FORMATI

SIZES / FORMATE / FORMATS

300 x 150 cm

120" x 60"

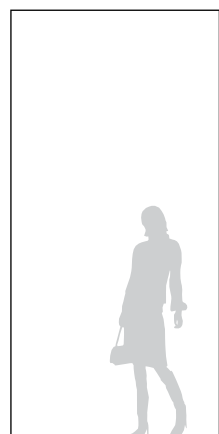

300 x 100 cm

120" x 40"

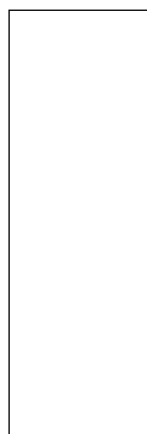

150 x 150 cm

60" x 60"



150 x 100 cm

60" x 40"

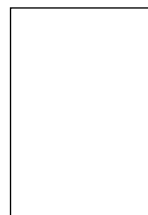

150 x 75 cm

60" x 30"

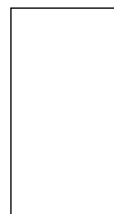

100 x 100 cm

40" x 40"

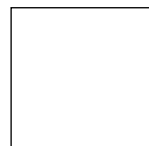

75 x 75 cm

30" x 30"

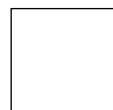

75 x 37,5 cm

30" x 15"



SUPERFICI / SURFACES / OBERFLÄCHEN / SURFACES

SHINY

SOFT

FORMATI pag. 338

SIZES pag. 338 / FORMATE pag. 338 / FORMATS pag. 338

300 X 150



CREMA MARFIL

METRO
ULTRA TECHNOLOGY by ARIOSTEA HIGH-TECH

ULTRA[®]

ARIOSTEA[®] HIGHTECH

MARMI

RETTIFICATO MONOCALIBRO

RECTIFIED SINGLE-CALIBRE /
REKTIFIZIERT EINKALIBRIG /
RECTIFIÉ MONOCALIBRE

SPESSORE

THICKNESS / DICKE / ÉPAISSEUR

▼
6mm
▲

FORMATI

SIZES / FORMATE / FORMATS

300 x 150 cm

120" x 60"

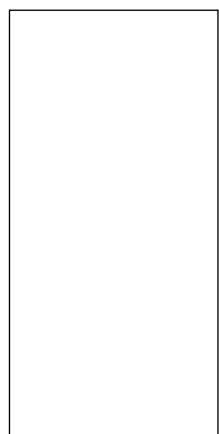

150 x 150 cm

60" x 60"



150 x 75 cm

60" x 30"

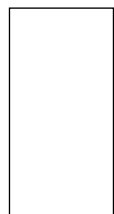

75 x 75 cm

30" x 30"

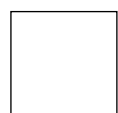

75 x 37,5 cm

30" x 15"



SUPERFICI / SURFACES / OBERFLÄCHEN / SURFACES

SHINY

SOFT

FORMATI pag. 338

SIZES pag. 338 / FORMATE pag. 338 / FORMATS pag. 338

300X150



GRIS DE SAVOIE

ULTRA[®]

ARIOSFEA[®] HIGHTECH

MARMI

RETTIFICATO MONOCALIBRO

RECTIFIED SINGLE-CALIBRE /
REKTIFIZIERT EINKALIBRIG /
RECTIFIÉ MONOCALIBRE

SPESSORE

THICKNESS / DICKE / ÉPAISSEUR

▼
6mm
▲

FORMATI

SIZES / FORMATE / FORMATS

300 x 150 cm

120" x 60"

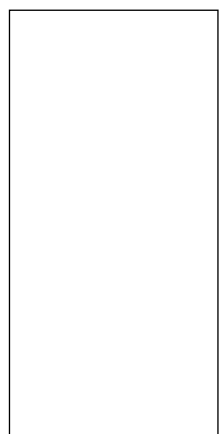

150 x 150 cm

60" x 60"



150 x 75 cm

60" x 30"

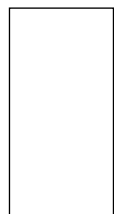

75 x 75 cm

30" x 30"

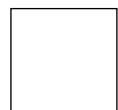

75 x 37,5 cm

30" x 15"



300X150

SUPERFICI / SURFACES / OBERFLÄCHEN / SURFACES

SHINY

SOFT

FORMATI pag. 338

SIZES pag. 338 / FORMATE pag. 338 / FORMATS pag. 338

TRAVERTINO SANTA CATERINA



ULTRA[®]

ARIOSFEA[®] HIGHTECH

MARMI

.....

RETTIFICATO MONOCALIBRO

RECTIFIED SINGLE-CALIBRE /
REKTIFIZIERT EINKALIBRIG /
RECTIFIÉ MONOCALIBRE

SPESSORE

THICKNESS / DICKE / ÉPAISSEUR

▼
6mm
▲

FORMATI

SIZES / FORMATE / FORMATS

300 x 150 cm

120" x 60"

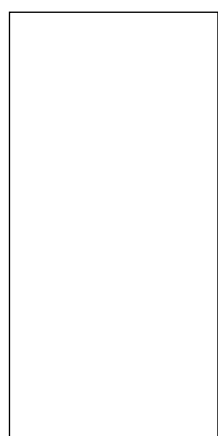

150 x 150 cm

60" x 60"



150 x 75 cm

60" x 30"



75 x 75 cm

30" x 30"



75 x 37,5 cm

30" x 15"



SUPERFICI / SURFACES / OBERFLÄCHEN / SURFACES

SHINY

FORMATI pag. 338

SIZES pag. 338 / FORMATE pag. 338 / FORMATS pag. 338

300 X 150

ERAMOSA BROWN

ULTRA®

ARIOSFEA® HIGHTECH

MARMI

.....

RETTIFICATO MONOCALIBRO

RECTIFIED SINGLE-CALIBRE /
REKTIFIZIERT EINKALIBRIG /
RECTIFIÉ MONOCALIBRE

SPESSORE

THICKNESS / DICKE / ÉPAISSEUR

▼
6mm
▲

FORMATI

SIZES / FORMATE / FORMATS

300 x 150 cm

120" x 60"

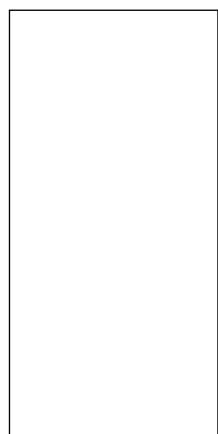

150 x 150 cm

60" x 60"

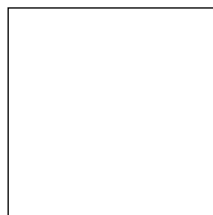

150 x 75 cm

60" x 30"



75 x 75 cm

30" x 30"

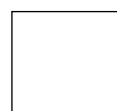

75 x 37,5 cm

30" x 15"



SUPERFICI / SURFACES / OBERFLÄCHEN / SURFACES

SHINY

FORMATI pag. 338

SIZES pag. 338 / FORMATE pag. 338 / FORMATS pag. 338

300 X 150

ZEBRINO BLACK

ULTRA[®]

ARIOSFEA[®] HIGHTECH

ONICI

RETTIFICATO MONOCALIBRO

RECTIFIED SINGLE-CALIBRE /
REKTIFIZIERT EINKALIBRIG /
RECTIFIÉ MONOCALIBRE

SPESSORE

THICKNESS / DICKE / ÉPAISSEUR

▼
6mm
▲

FORMATI

SIZES / FORMATE / FORMATS

300 x 150 cm

120" x 60"

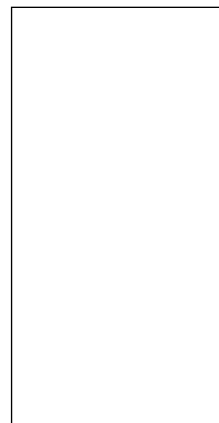

150 x 150 cm

60" x 60"

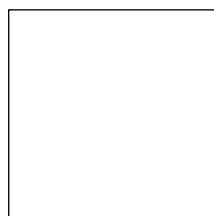

150 x 75 cm

60" x 30"

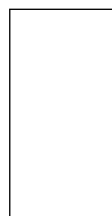

75 x 75 cm

30" x 30"

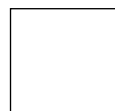

75 x 37,5 cm

30" x 15"



SUPERFICI / SURFACES / OBERFLÄCHEN / SURFACES

SHINY

SOFT

FORMATI pag. 339

SIZES pag. 339 / FORMATE pag. 339 / FORMATS pag. 339

300 X 150

ONICE GRIGIO



ULTRA[®]

ARIOSFEA[®] HIGHTECH

ONICI

.....

RETTIFICATO MONOCALIBRO

RECTIFIED SINGLE-CALIBRE /
REKTIFIZIERT EINKALIBRIG /
RECTIFIÉ MONOCALIBRE

SPESSORE

THICKNESS / DICKE / ÉPAISSEUR

▼
6mm
▲

FORMATI

SIZES / FORMATE / FORMATS

300 x 150 cm

120" x 60"

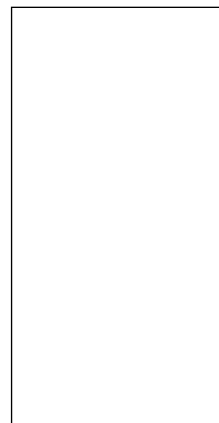

150 x 150 cm

60" x 60"

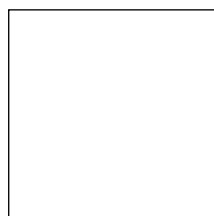

150 x 75 cm

60" x 30"

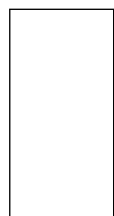

75 x 75 cm

30" x 30"

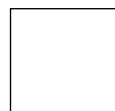

75 x 37,5 cm

30" x 15"



SUPERFICI / SURFACES / OBERFLÄCHEN / SURFACES

SHINY

SOFT

FORMATI pag. 339

SIZES pag. 339 / FORMATE pag. 339 / FORMATS pag. 339

300 X 150

ONICE BIANCO EXTRA



ULTRA[®]

ARIOSFEA[®] HIGHTECH

ONICI

.....

RETTIFICATO MONOCALIBRO

RECTIFIED SINGLE-CALIBRE /
REKTIFIZIERT EINKALIBRIG /
RECTIFIÉ MONOCALIBRE

SPESSORE

THICKNESS / DICKE / ÉPAISSEUR

▼
6mm
▲

FORMATI

SIZES / FORMATE / FORMATS

300 x 150 cm

120" x 60"

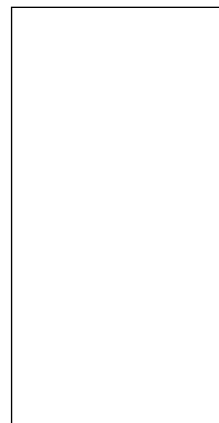

150 x 150 cm

60" x 60"

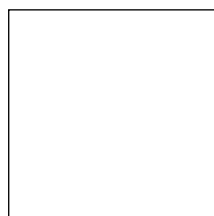

150 x 75 cm

60" x 30"

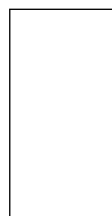

75 x 75 cm

30" x 30"

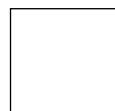

75 x 37,5 cm

30" x 15"



SUPERFICI / SURFACES / OBERFLÄCHEN / SURFACES

SHINY

SOFT

FORMATI pag. 339

SIZES pag. 339 / FORMATE pag. 339 / FORMATS pag. 339

300 X 150

ONICE BEIGE

ULTRA[®]

ARIOSFEA[®] HIGHTECH

P i e t r e

.....

RETTIFICATO MONOCALIBRO

RECTIFIED SINGLE-CALIBRE /
REKTIFIZIERT EINKALIBRIG /
RECTIFIÉ MONOCALIBRE

SPESSORE

THICKNESS / DICKE / ÉPAISSEUR

▼
6mm
▲

FORMATI

SIZES / FORMATE / FORMATS

300 x 100 cm

120" x 40"

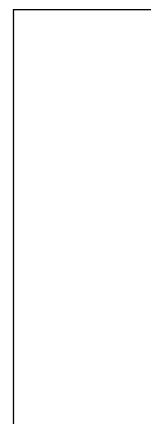

150 x 100 cm

60" x 40"

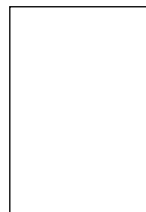

100 x 100 cm

40" x 40"

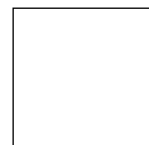

SUPERFICI / SURFACES / OBERFLÄCHEN / SURFACES

SOFT

PRELUCIDATO

FORMATI pag. 338

SIZES pag. 338 / FORMATE pag. 338 / FORMATS pag. 338

BASALTINA WHITE

ULTRA[®]

ARIOSFEA[®] HIGHTECH

P i e t r e

.....

RETTIFICATO MONOCALIBRO

RECTIFIED SINGLE-CALIBRE /
REKTIFIZIERT EINKALIBRIG /
RECTIFIÉ MONOCALIBRE

SPESSORE

THICKNESS / DICKE / ÉPAISSEUR

▼
6mm
▲

FORMATI

SIZES / FORMATE / FORMATS

300 x 100 cm

120" x 40"

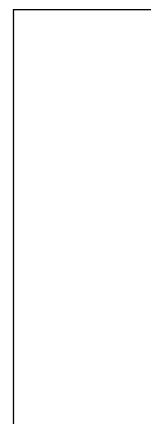

150 x 100 cm

60" x 40"

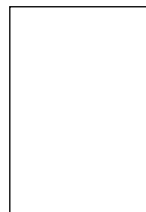

100 x 100 cm

40" x 40"

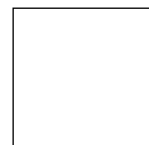

SUPERFICI / SURFACES / OBERFLÄCHEN / SURFACES

SOFT

PRELUCIDATO

FORMATI pag. 338

SIZES pag. 338 / FORMATE pag. 338 / FORMATS pag. 338

BASALTINA SAND

ULTRA[®]

ARIOSFEA[®] HIGHTECH

P i e t r e

.....

RETTIFICATO MONOCALIBRO

RECTIFIED SINGLE-CALIBRE /
REKTIFIZIERT EINKALIBRIG /
RECTIFIÉ MONOCALIBRE

SPESSORE

THICKNESS / DICKE / ÉPAISSEUR

▼
6mm
▲

FORMATI

SIZES / FORMATE / FORMATS

300 x 100 cm

120" x 40"

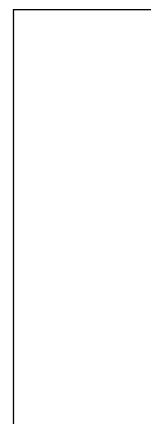

150 x 100 cm

60" x 40"

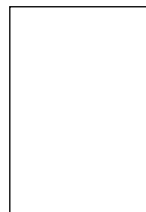

100 x 100 cm

40" x 40"

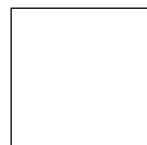

SUPERFICI / SURFACES / OBERFLÄCHEN / SURFACES

SOFT

PRELUCIDATO

FORMATI pag. 338

SIZES pag. 338 / FORMATE pag. 338 / FORMATS pag. 338



BASALTINA GREY

ULTRA[®]

ARIOSFEA[®] HIGHTECH

P i e t r e

RETTIFICATO MONOCALIBRO

RECTIFIED SINGLE-CALIBRE /
REKTIFIZIERT EINKALIBRIG /
RECTIFIÉ MONOCALIBRE

SPESSORE

THICKNESS / DICKE / ÉPAISSEUR

▼
6mm
▲

FORMATI

SIZES / FORMATE / FORMATS

300 x 100 cm

120" x 40"

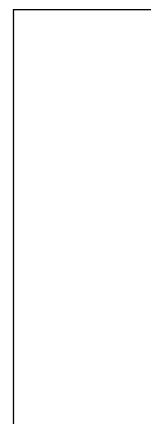

150 x 100 cm

60" x 40"

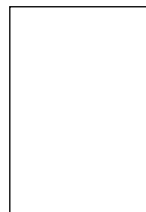

100 x 100 cm

40" x 40"

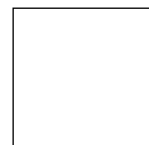

SUPERFICI / SURFACES / OBERFLÄCHEN / SURFACES

SOFT

PRELUCIDATO

FORMATI pag. 338

SIZES pag. 338 / FORMATE pag. 338 / FORMATS pag. 338



BASALTINA MOKA

ULTRA[®]

ARIOSFEA[®] HIGHTECH

P i e t r e

.....

RETTIFICATO MONOCALIBRO

RECTIFIED SINGLE-CALIBRE /
REKTIFIZIERT EINKALIBRIG /
RECTIFIÉ MONOCALIBRE

SPESSORE

THICKNESS / DICKE / ÉPAISSEUR

▼
6mm
▲

FORMATI

SIZES / FORMATE / FORMATS

300 x 100 cm

120" x 40"

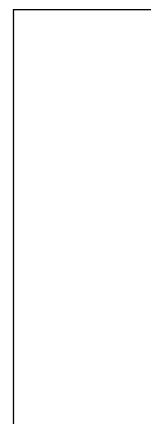

150 x 100 cm

60" x 40"

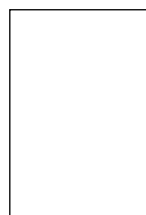

100 x 100 cm

40" x 40"

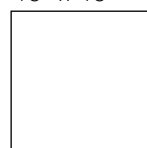

SUPERFICI / SURFACES / OBERFLÄCHEN / SURFACES

SOFT

PRELUCIDATO

FORMATI pag. 338

SIZES pag. 338 / FORMATE pag. 338 / FORMATS pag. 338

BASALTINA ANTRACITE

ULTRA[®]

ARIOSFEA[®] HIGHTECH

P i e t r e

.....

RETTIFICATO MONOCALIBRO

RECTIFIED SINGLE-CALIBRE /
REKTIFIZIERT EINKALIBRIG /
RECTIFIÉ MONOCALIBRE

SPESSORE

THICKNESS / DICKE / ÉPAISSEUR

▼
6mm
▲

FORMATI

SIZES / FORMATE / FORMATS

300 x 100 cm

120" x 40"

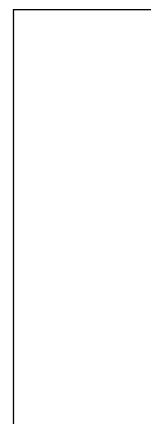

150 x 100 cm

60" x 40"

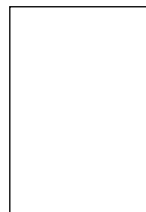

100 x 100 cm

40" x 40"

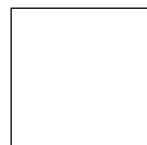

SUPERFICI / SURFACES / OBERFLÄCHEN / SURFACES

STRUCTURED

FORMATI pag. 338

SIZES pag. 338 / FORMATE pag. 338 / FORMATS pag. 338

JERUSALEM LIMESTONE

ULTRA[®]

ARIOSFEA[®] HIGHTECH

P i e t r e

.....

RETTIFICATO MONOCALIBRO

RECTIFIED SINGLE-CALIBRE /
REKTIFIZIERT EINKALIBRIG /
RECTIFIÉ MONOCALIBRE

SPESSORE

THICKNESS / DICKE / ÉPAISSEUR

▼
6mm
▲

FORMATI

SIZES / FORMATE / FORMATS

300 x 100 cm

120" x 40"

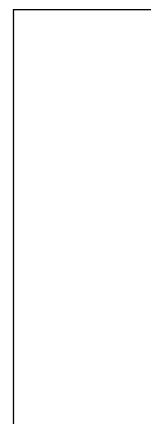

150 x 100 cm

60" x 40"

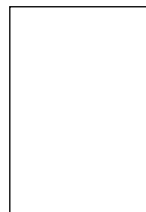

100 x 100 cm

40" x 40"

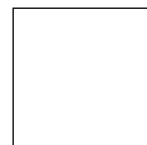

SUPERFICI / SURFACES / OBERFLÄCHEN / SURFACES

STRUCTURED

FORMATI pag. 338

SIZES pag. 338 / FORMATE pag. 338 / FORMATS pag. 338

AZUL BATEIG LIMESTONE

ULTRA[®]

ARIOSFEA[®] HIGHTECH

P i e t r e

.....

RETTIFICATO MONOCALIBRO

RECTIFIED SINGLE-CALIBRE /
REKTIFIZIERT EINKALIBRIG /
RECTIFIÉ MONOCALIBRE

SPESSORE

THICKNESS / DICKE / ÉPAISSEUR

▼
6mm
▲

FORMATI

SIZES / FORMATE / FORMATS

300 x 100 cm

120" x 40"

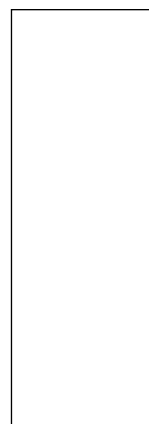

150 x 100 cm

60" x 40"

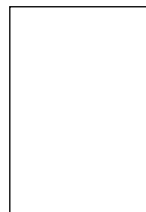

100 x 100 cm

40" x 40"

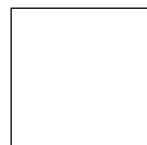

SUPERFICI / SURFACES / OBERFLÄCHEN / SURFACES

STRUCTURED

FORMATI pag. 338

SIZES pag. 338 / FORMATE pag. 338 / FORMATS pag. 338

SAN VICENTE LIMESTONE

ULTRA[®]

ARIOSTEA[®] HIGHTECH

R e s i n e

.....

RETTIFICATO MONOCALIBRO

RECTIFIED SINGLE-CALIBRE /
REKTIFIZIERT EINKALIBRIG /
RECTIFIÉ MONOCALIBRE

SPESSORE

THICKNESS / DICKE / ÉPAISSEUR

▼
6mm
▲

FORMATI

SIZES / FORMATE / FORMATS

300 x 100 cm

120" x 40"

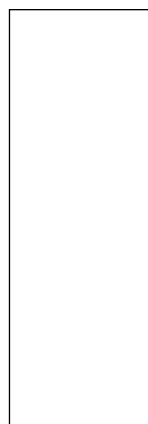

150 x 100 cm

60" x 40"

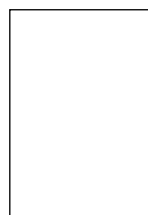

100 x 100 cm

40" x 40"

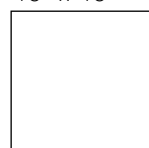

SUPERFICI / SURFACES / OBERFLÄCHEN / SURFACES

SOFT

PRELUCIDATO

FORMATI pag. 339

SIZES pag. 339 / FORMATE pag. 339 / FORMATS pag. 339

METRO

ULTRA TECHNOLOGY by ARIOSTEA HIGH-TECH



CALCE



EBANO



PIOMBO



SILICIO

ULTRA[®]

ARIOSTEA[®] HIGHTECH

iCementi

.....

RETTIFICATO MONOCALIBRO

RECTIFIED SINGLE-CALIBRE /
REKTIFIZIERT EINKALIBRIG /
RECTIFIÉ MONOCALIBRE

SPESSORE

THICKNESS / DICKE / ÉPAISSEUR

▼
6mm
▲

FORMATI

SIZES / FORMATE / FORMATS

300 x 150 cm
120" x 60"

300 x 100 cm
120" x 40"

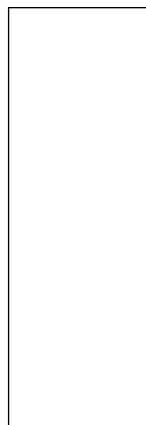
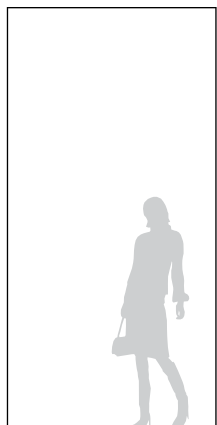

150 x 150 cm
60" x 60"



150 x 100 cm
60" x 40"



150 x 75 cm
60" x 30"



100 x 100 cm
40" x 40"

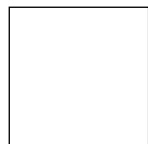

75 x 75 cm
30" x 30"

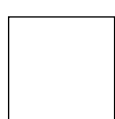

75 x 37,5 cm
30" x 15"



SUPERFICI / SURFACES / OBERFLÄCHEN / SURFACES

SOFT

FORMATI pag. 338

SIZES pag. 338 / FORMATE pag. 338 / FORMATS pag. 338

300 X 150

METRO

ULTRA TECHNOLOGY by ARIOSTEA HIGH-TECH

GRAPHITE

IRON

SILVER

IVORY

BRONZE

ULTRA[®]

ARIOSTEA[®] HIGHTECH

IRIDIUM

.....

RETTIFICATO MONOCALIBRO

RECTIFIED SINGLE-CALIBRE /
REKTIFIZIERT EINKALIBRIG /
RECTIFIÉ MONOCALIBRE

SPESSORE

THICKNESS / DICKE / ÉPAISSEUR

▼
6mm
▲

FORMATI

SIZES / FORMATE / FORMATS

300 x 150 cm

120" x 60"

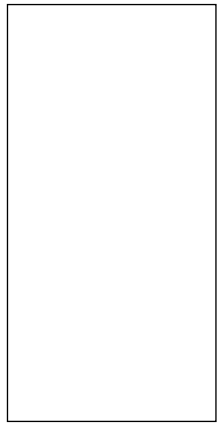

300 x 100 cm

120" x 40"

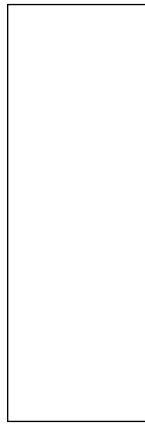

150 x 150 cm

60" x 60"

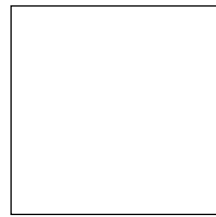

150 x 100 cm

60" x 40"

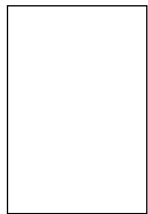

150 x 75 cm

60" x 30"

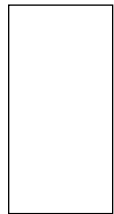

100 x 100 cm

40" x 40"

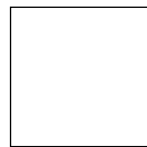

75 x 75 cm

30" x 30"

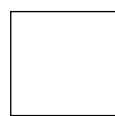

SUPERFICI / SURFACES / OBERFLÄCHEN / SURFACES

SHINY

SOFT

FORMATI pag. 339

SIZES pag. 339 / FORMATE pag. 339 / FORMATS pag. 339

300 X 150

METRO

ULTRA TECHNOLOGY by ARIOSTEA HIGH-TECH

NERO

BIANCO

GRIGIO

ULTRA[®]

ARIOSTEA[®] HIGHTECH

WOOD

RETTIFICATO MONOCALIBRO

RECTIFIED SINGLE-CALIBRE /
REKTIFIZIERT EINKALIBRIG /
RECTIFIÉ MONOCALIBRE

SPESSORE

THICKNESS / DICKE / ÉPAISSEUR

▼
6mm
▲

FORMATI

SIZES / FORMATE / FORMATS

180 x 21,5 cm

72" x 8¹/₂"



SUPERFICI / SURFACES / OBERFLÄCHEN / SURFACES

SOFT

FORMATI pag. 339

SIZES pag. 339 / FORMATE pag. 339 / FORMATS pag. 339





NOCE CALCE

NOCE CHIARO

NOCE OSSIDATO

NOCE AMERICANO

NOCE SCURO

FINITURE /
FINISH /
OBERFLÄCHENAUSFÜHRUNG /
FINITION

LEVIGATO E LUCIDATO /
HONED AND POLISHED /
GESCHLIFFEN UND POLIERT /
POLI ET LUSTRÉ

PRELEVIGATO /
PREPOLISHED /
VORGESCHLIFFEN /
PRÉPOLI
R9

ANTICATO /
ANTIQUED /
ANTIQUÉ /
ANTIQUE
R9 - A / INNOVATIVE SLABS PIETRE NATURALI HIGH-TECH

HIGH-HONED

SOFT
R9 / R10 - A+B



BAMBOO

R12 - A+B+C

NATURALE /

NATURAL /

NATURBELASSEN /

NATUREL

R9 - A / R9 - A+B / R10 - A / R10 - A+B

SEMILUCIDATO /

SEMI-POLISHED /

SEMI-MATT /

SEMI-LUSTRÉ

R10 - A

STRUTTURATO /

STRUCTURED /

STRUKTURIERT /

STRUCTURÉ

R10 A+B / R11 - A / R11 - A+B / R11 - A+B+C

ANTICATO /

ANTIQUED /

ANTIK /

ANTIQUE

R9 - A / R10 - A / R10 - A+B / R10

A+B+C / R11 - A / R11 - A+B / R11 A+B+C

INNOVATIVE SLABS LEGNI HIGH-TECH / LEGNI HIGH-TECH

BOCCIARDATO /

BUSHHAMMERED /

GESTOCKT /

BOUCHARDÉ

R11 - A+B+C

SATINATO /

SATIN-FINISH /

SATINIERT /

SATINÉ

R9 / R10 - A / R10 - A+B / R10 - A+B+C

THASSOS	100
STATUARIO	102
BIANCO PAONAZZETTO	104
GRIGIO DEI CARPAZI	106
TRAVERTINO NAVONA	108
AVORIO DI SICILIA	110
GIALLO DI SIENA	112
ROSSO ALICANTE	114
NOIR ST. LAURENT	116
SKYROS	118
ESTREMOZ	120
CREMA MARFIL	122
BOTTICINO	124
ROSA PORTOGALLO	126
VERDE ALPI	128
DARK EMPERADOR	130
NERO MARQUINIA	132

MARMI HIGH-TECH

MARMI HIGH-TECH & INNOVATIVE SLABS

THASSOS

INNOVATIVE SLABS

PROVENIENZA GRECIA

ORIGIN GREECE / HERKUNFT GRIECHENLAND /
PROVENANCE GRÈCE

REPERIBILITÀ ESTREMAMENTE LIMITATA

AVAILABILITY VERY SCARCE /
VERFÜGBARKEIT ÄUSSERST BEGRENZT /
DISPONIBILITÉ EXTRÊ MEMENT LIMITÉE

RETTIFICATO MONOCALIBRO

RECTIFIED SINGLE-CALIBRE / REKTIFIZIERT EINKALIBRIG /
RECTIFIÉ MONOCALIBRE

SPESSORE

THICKNESS / DICKE / ÉPAISSEUR

9,5mm

FORMATI

SIZES / FORMATE / FORMATS

150 x 75 cm

60" x 30"

75 x 9 cm

30" x 3³/₅"

75 x 75 cm

30" x 30"

75 x 37,5 cm

30" x 15"

120 x 60 cm

48" x 24"

90 x 90 cm

36" x 36"

90 x 45 cm

36" x 17³/₄"

90 x 9 cm

36" x 3³/₅"

60 x 60 cm

24" x 24"

60 x 9 cm 24" x 3³/₅"

45 x 45 cm

17³/₄" x 17³/₄"

45 x 9 cm

17³/₄" x 3³/₅"

9 x 9 cm 3³/₅" x 3³/₅"

SUPERFICI

SURFACES
OBERFLÄCHEN
SURFACES

COEFFICIENTE DI ATTRITO

FRICITION COEFFICIENT
REIBUNGSKOEFFIZIENT
COEFFICIENT DE FROTTEMENT

FORMATI / SIZES / FORMATE / FORMATS

PEZZI SPECIALI / TRIMS / FORMTEILE / PIÈCES SPÉCIALES

DECORI E MOSAICI / DECORS AND MOSAICS / DEKORE UND MOSAIKE / DECORS ET MOSAÏQUE

DI CAVA

DI FABBRICA

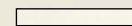
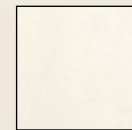
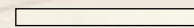
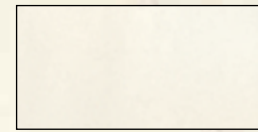
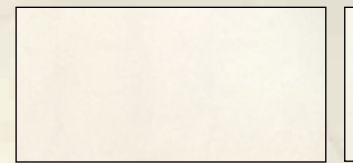

LEVIGATO E LUCIDATO / HONED AND POLISHED /
GESCHLIFFEN UND POLIERT / POLI ET LUSTRÉ

PRELEVIGATO / PREPOLISHED / VORGESCHLIFFEN / PRÉPOLI

PR (R9)

pag. 340

pag. 341

pag. 342

150X75

STATUARIO

PROVENIENZA ITALIA

ORIGIN ITALY / HERKUNFT ITALIEN /
PROVENANCE ITALIE

REPERIBILITÀ ESTREMAMENTE LIMITATA

AVAILABILITY VERY SCARCE /
VERFÜGBARKEIT ÄUSSERST BEGRENZT /
DISPONIBILITÉ EXTRÊ MEMENT LIMITÉE

RETTIFICATO MONOCALIBRO

RECTIFIED SINGLE-CALIBRE / REKTIFIZIERT EINKALIBRIG /
RECTIFIÉ MONOCALIBRE

SPESSORE

THICKNESS / DICKE / ÉPAISSEUR

▼
9,5mm
▲

FORMATI

SIZES / FORMATE / FORMATS

150 x 75 cm
60" x 30"

75 x 75 cm
30" x 30"

75 x 37,5 cm
30" x 15"

75 x 9 cm
30" x 3³/₅"

120 x 60 cm
48" x 24"

60 x 60 cm
24" x 24"

60 x 30 cm
24" x 12"

60 x 9 cm
24" x 3³/₅"

9 x 9 cm
3³/₅" x 3³/₅"

SUPERFICI

SURFACES
OBERFLÄCHEN
SURFACES

COEFFICIENTE DI ATTRITO

FRICTION COEFFICIENT
REIBUNGSKOEFFIZIENT
COEFFICIENT DE FROTTEMENT

FORMATI / SIZES / FORMATE / FORMATS

PEZZI SPECIALI / TRIMS / FORMTEILE / PIÈCES SPÉCIALES

DECORI E MOSAICI / DECORS AND MOSAICS / DEKORE UND MOSAIKE / DECORS ET MOSAÏQUE

INNOVATIVE SLABS

DI CAVA

DI FABBRICA

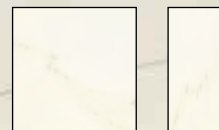
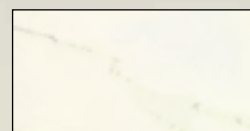
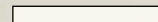
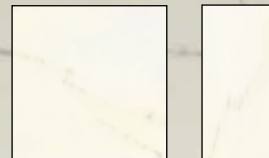

LEVIGATO E LUCIDATO / HONED AND POLISHED /
GESCHLIFFEN UND POLIERT / POLI ET LUSTRÉ

PRELEVIGATO / PREPOLISHED / VORGESCHLIFFEN / PRÉPOLI

PR **(R9)**

pag. 340

pag. 341

pag. 342

150X75



BIANCO PAONAZZETTO

PROVENIENZA ITALIA
ORIGIN ITALY / HERKUNFT ITALIEN /
PROVENANCE ITALIE

REPERIBILITÀ LIMITATA
AVAILABILITY SCARCE /
VERFÜGBARKEIT BEGRENZT /
DISPONIBILITÉ LIMITÉE

RETTIFICATO MONOCALIBRO
RECTIFIED SINGLE-CALIBRE / REKTIFIZIERT EINKALIBRIG /
RECTIFIÉ MONOCALIBRE

SPESSORE
THICKNESS / DICKE / ÉPAISSEUR

▼
9,5mm
▲

FORMATI
SIZES / FORMATE / FORMATS

150 x 75 cm
60" x 30"

75 x 75 cm
30" x 30"

75 x 37,5 cm
30" x 15"

75 x 9 cm
30" x 3^{3/5}"

SUPERFICI
SURFACES
OBERFLÄCHEN
SURFACES

COEFFICIENTE DI ATTRITO
FRICTION COEFFICIENT
REIBUNGSKOEFFIZIENT
COEFFICIENT DE FROTTEMENT

FORMATI / SIZES / FORMATE / FORMATS
PEZZI SPECIALI / TRIMS / FORMTEILE / PIÈCES SPÉCIALES

DECORI E MOSAICI / DECORS AND MOSAICS / DEKORE UND MOSAIKE / DECORS ET MOSAÏQUE

INNOVATIVE SLABS

DI CAVA

DI FABBRICA



LEVIGATO E LUCIDATO / HONED AND POLISHED /
GESCHLIFFEN UND POLIERT / POLI ET LUSTRÉ

PRELEVIGATO / PREPOLISHED / VORGESCHLIFFEN / PRÉPOLI

PR (R9)

pag. 340

pag. 341

pag. 342

150X75

GRIGIO DEI CARPAZI

PROVENIENZA ROMANIA

ORIGIN ROMANIA / HERKUNFT RUMÄNIEN /
PROVENANCE ROUMANIE

REPERIBILITÀ MODESTA

AVAILABILITY SCARCE /
VERFÜGBARKEIT BESCHIEDEN /
DISPONIBILITÉ MODESTE

RETTIFICATO MONOCALIBRO

RECTIFIED SINGLE-CALIBRE / REKTIFIZIERT EINKALIBRIG /
RECTIFIÉ MONOCALIBRE

SPESSORE

THICKNESS / DICKE / ÉPAISSEUR

▼
9,5mm
▲

FORMATI

SIZES / FORMATE / FORMATS

150 x 75 cm
60" x 30"

75 x 75 cm
30" x 30"

75 x 37,5 cm
30" x 15"

75 x 9 cm
30" x 3³/₅"

SUPERFICI

SURFACES
OBERFLÄCHEN
SURFACES

COEFFICIENTE DI ATTRITO

FRICTION COEFFICIENT
REIBUNGSKOEFFIZIENT
COEFFICIENT DE FROTTEMENT

FORMATI / SIZES / FORMATE / FORMATS

PEZZI SPECIALI / TRIMS / FORMTEILE / PIÈCES SPÉCIALES

DECORI E MOSAICI / DECORS AND MOSAICS / DEKORE UND MOSAIKE / DECORS ET MOSAÏQUE

INNOVATIVE SLABS

DI CAVA

DI FABBRICA

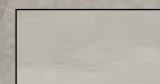

LEVIGATO E LUCIDATO / HONED AND POLISHED /
GESCHLIFFEN UND POLIERT / POLI ET LUSTRÉ

PRELEVIGATO / PREPOLISHED / VORGESCHLIFFEN / PRÉPOLI

PR (R9)

pag. 340

pag. 341

pag. 342

150X75

TRAVERTINO NAVONA

PROVENIENZA ITALIA

ORIGIN ITALY / HERKUNFT ITALIEN /
PROVENANCE ITALIE

REPERIBILITÀ BUONA

AVAILABILITY GOOD /
VERFÜGBARKEIT REICHLICH /
DISPONIBILITÉ BONNE

RETTIFICATO MONOCALIBRO

RECTIFIED SINGLE-CALIBRE / REKTIFIZIERT EINKALIBRIG /
RECTIFIÉ MONOCALIBRE

SPESSORE

THICKNESS / DICKE / ÉPAISSEUR

▼
9,5mm
▲

FORMATI

SIZES / FORMATE / FORMATS

150 x 75 cm

60" x 30"

75 x 9 cm

30" x 3³/₅"

75 x 75 cm

30" x 30"

75 x 37,5 cm

30" x 15"

120 x 60 cm

48" x 24"

90 x 90 cm

36" x 36"

90 x 45 cm

36" x 17³/₄"

90 x 9 cm 36" x 3³/₅"

60 x 60 cm

24" x 24"

60 x 30 cm

24" x 12"

60 x 9 cm 24" x 3³/₅"

45 x 45 cm

17³/₄" x 17³/₄"

45 x 9 cm

17³/₄" x 3³/₅"

9 x 9 cm 3³/₅" x 3³/₅"

SUPERFICI

SURFACES
OBERFLÄCHEN
SURFACES

COEFFICIENTE DI ATTRITO

FRICITION COEFFICIENT
REIBUNGSKOEFFIZIENT
COEFFICIENT DE FROTTEMENT

FORMATI / SIZES / FORMATE / FORMATS

PEZZI SPECIALI / TRIMS / FORMTEILE / PIÈCES SPÉCIALES

DECORI E MOSAICI / DECORS AND MOSAICS / DEKORE UND MOSAIKE / DECORS ET MOSAIQUE

INNOVATIVE SLABS

DI CAVA

DI FABBRICA

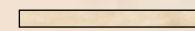

LEVIGATO E LUCIDATO / HONED AND POLISHED /
GESCHLIFFEN UND POLIERT / POLI ET LUSTRÉ

PRELEVIGATO / PREPOLISHED / VORGESCHLIFFEN / PRÉPOLI

PR **R9**

pag. 340

pag. 341

pag. 342

150X75

AVORIO DI SICILIA

PROVENIENZA ITALIA
ORIGIN ITALY / HERKUNFT ITALIEN /
PROVENANCE ITALIE

REPERIBILITÀ BUONA
AVAILABILITY GOOD /
VERFÜGBARKEIT REICHLICH /
DISPONIBILITÉ BONNE

RETTIFICATO MONOCALIBRO
RECTIFIED SINGLE-CALIBRE / REKTIFIZIERT EINKALIBRIG /
RECTIFIÉ MONOCALIBRE

SPESSORE
THICKNESS / DICKE / ÉPAISSEUR

9,5mm

FORMATI
SIZES / FORMATE / FORMATS

150 x 75 cm
60" x 30"

75 x 75 cm
30" x 30"

75 x 37,5 cm
30" x 15"

75 x 9 cm
30" x 3^{3/5}"

SUPERFICI
SURFACES
OBERFLÄCHEN
SURFACES

COEFFICIENTE DI ATTRITO
FRICTION COEFFICIENT
REIBUNGSKOEFFIZIENT
COEFFICIENT DE FROTTEMENT

FORMATI / SIZES / FORMATE / FORMATS
PEZZI SPECIALI / TRIMS / FORMTEILE / PIÈCES SPÉCIALES

DECORI E MOSAICI / DECORS AND MOSAICS / DEKORE UND MOSAIKE / DECORS ET MOSAIQUE

INNOVATIVE SLABS

DI CAVA

DI FABBRICA

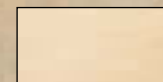
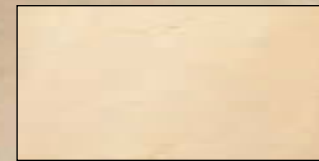

LEVIGATO E LUCIDATO / HONED AND POLISHED /
GESCHLIFFEN UND POLIERT / POLI ET LUSTRÉ

PRELEVIGATO / PREPOLISHED / VORGESCHLIFFEN / PRÉPOLI

PR (R9)

pag. 340
pag. 341
pag. 342

150X75

GIALLO DI SIENA

PROVENIENZA ITALIA
ORIGIN ITALY / HERKUNFT ITALIEN /
PROVENANCE ITALIE

REPERIBILITÀ LIMITATA
AVAILABILITY SCARCE /
VERFÜGBARKEIT BEGRENZT /
DISPONIBILITÉ LIMITÉE

RETTIFICATO MONOCALIBRO
RECTIFIED SINGLE-CALIBRE / REKTIFIZIERT EINKALIBRIG /
RECTIFIÉ MONOCALIBRE

SPESSORE
THICKNESS / DICKE / ÉPAISSEUR

▼
9,5mm
▲

FORMATI
SIZES / FORMATE / FORMATS

150 x 75 cm
60" x 30"

75 x 75 cm
30" x 30"

75 x 37,5 cm
30" x 15"

75 x 9 cm
30" x 3^{3/5}"

SUPERFICI
SURFACES
OBERFLÄCHEN
SURFACES

COEFFICIENTE DI ATTRITO
FRICTION COEFFICIENT
REIBUNGSKOEFFIZIENT
COEFFICIENT DE FROTTEMENT

FORMATI / SIZES / FORMATE / FORMATS

PEZZI SPECIALI / TRIMS / FORMTEILE / PIÈCES SPÉCIALES

DECORI E MOSAICI / DECORS AND MOSAICS / DEKORE UND MOSAIKE / DECORS ET MOSAIQUE

INNOVATIVE SLABS

DI CAVA

DI FABBRICA



LEVIGATO E LUCIDATO / HONED AND POLISHED /
GESCHLIFFEN UND POLIERT / POLI ET LUSTRÉ

PR (R9)

pag. 340

pag. 341

pag. 342

150X75

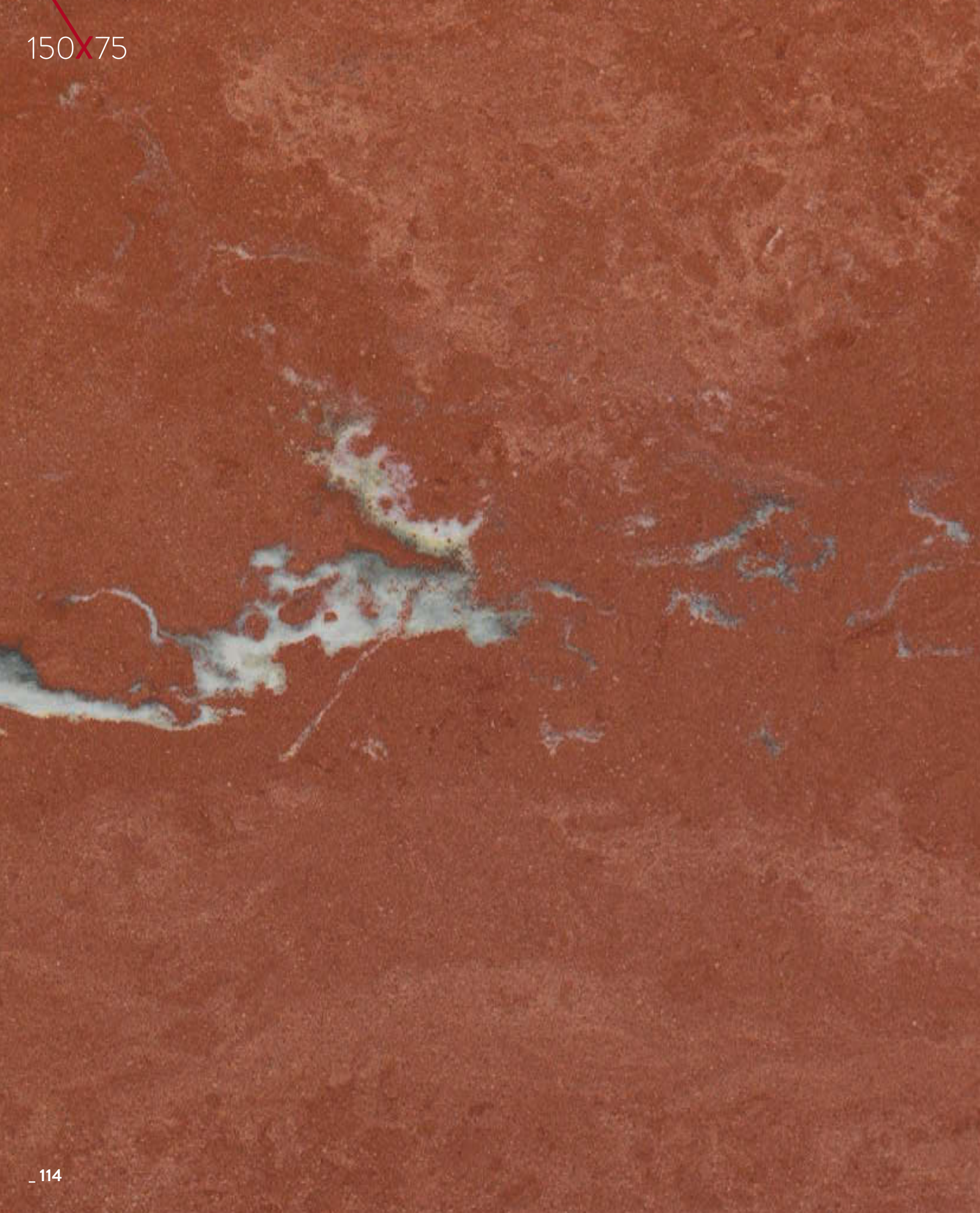

ROSSO ALICANTE

PROVENIENZA SPAGNA
ORIGIN SPAIN / HERKUNFT SPANIEN /
PROVENANCE ESPAGNE

REPERIBILITÀ BUONA
AVAILABILITY GOOD /
VERFÜGBARKEIT REICHLICH /
DISPONIBILITÉ BONNE

RETTIFICATO MONOCALIBRO
RECTIFIED SINGLE-CALIBRE / REKTIFIZIERT EINKALIBRIG /
RECTIFIÉ MONOCALIBRE

SPESSORE
THICKNESS / DICKE / ÉPAISSEUR

9,5mm

FORMATI
SIZES / FORMATE / FORMATS

150 x 75 cm
60" x 30"

75 x 75 cm
30" x 30"

75 x 37,5 cm
30" x 15"

75 x 9 cm
30" x 3^{3/5}"

SUPERFICI
SURFACES
OBERFLÄCHEN
SURFACES

COEFFICIENTE DI ATTRITO
FRICTION COEFFICIENT
REIBUNGSKOEFFIZIENT
COEFFICIENT DE FROTTEMENT

FORMATI / SIZES / FORMATE / FORMATS
PEZZI SPECIALI / TRIMS / FORMTEILE / PIÈCES SPÉCIALES

DECORI E MOSAICI / DECORS AND MOSAICS / DEKORE UND MOSAIKE / DECORS ET MOSAIQUE

INNOVATIVE SLABS

DI CAVA

DI FABBRICA



**LEVIGATO E LUCIDATO / HONED AND POLISHED /
GESCHLIFFEN UND POLIERT / POLI ET LUSTRÉ**

PRELEVIGATO / PREPOLISHED / VORGESCHLIFFEN / PRÉPOLI

PR **R9**

pag. 340

pag. 341

pag. 342

NOIR ST. LAURENT

PROVENIENZA FRANCIA

ORIGIN FRANCE / HERKUNFT FRANKREICH /
PROVENANCE FRANCE

REPERIBILITÀ ESTREMAMENTE LIMITATA

AVAILABILITY VERY SCARCE /
VERFÜGBARKEIT ÄUSSERST BEGRENZT /
DISPONIBILITÉ EXTRÊ MEMENT LIMITÉE

RETTIFICATO MONOCALIBRO

RECTIFIED SINGLE-CALIBRE / REKTIFIZIERT EINKALIBRIG /
RECTIFIÉ MONOCALIBRE

SPESSORE

THICKNESS / DICKE / ÉPAISSEUR

9,5mm

FORMATI

SIZES / FORMATE / FORMATS

150 x 75 cm

60" x 30"

75 x 9 cm

30" x 3^{3/5}"

75 x 75 cm

30" x 30"

75 x 37,5 cm

30" x 15"

90 x 45 cm

36" x 17^{3/4}"

90 x 9 cm

36" x 3^{3/5}"

60 x 60 cm

24" x 24"

60 x 30 cm

24" x 12"

60 x 9 cm

24" x 3^{3/5}"

45 x 45 cm

17^{3/4}" x 17^{3/4}"

45 x 9 cm 17^{3/4}" x 3^{3/5}"

9 x 9 cm 3^{3/5}" x 3^{3/5}"

SUPERFICI

SURFACES
OBERFLÄCHEN
SURFACES

COEFFICIENTE DI ATTRITO

FRICTION COEFFICIENT
REIBUNGSKOEFFIZIENT
COEFFICIENT DE FROTTEMENT

FORMATI / SIZES / FORMATE / FORMATS

PEZZI SPECIALI / TRIMS / FORMTEILE / PIÈCES SPÉCIALES

DECORI E MOSAICI / DECORS AND MOSAICS / DEKORE UND MOSAIKE / DECORS ET MOSAIQUE

INNOVATIVE SLABS

DI CAVA

DI FABBRICA

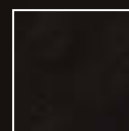
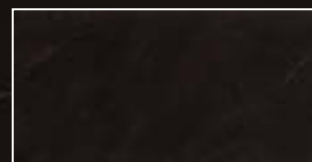

LEVIGATO E LUCIDATO / HONED AND POLISHED /
GESCHLIFFEN UND POLIERT / POLI ET LUSTRÉ

PRELEVIGATO / PREPOLISHED / VORGESCHLIFFEN / PRÉPOLI

PR (R9)

pag. 340

pag. 341

pag. 342

SKYROS

MARMI HIGH-TECH

PROVENIENZA GRECIA

ORIGIN GREECE / HERKUNFT GRIECHENLAND /
PROVENANCE GRÈCE

REPERIBILITÀ ESTREMAMENTE LIMITATA

AVAILABILITY VERY SCARCE /
VERFÜGBARKEIT ÄUSSERST BEGRENZT /
DISPONIBILITÉ EXTRÊ MEMENT LIMITÉE

RETTIFICATO MONOCALIBRO

RECTIFIED SINGLE-CALIBRE / REKTIFIZIERT EINKALIBRIG /
RECTIFIÉ MONOCALIBRE

SPESSORE

THICKNESS / DICKE / ÉPAISSEUR

▼
9,5mm
▲

FORMATI

SIZES / FORMATE / FORMATS

90 x 45 cm
36" x 17^{3/4}"

90 x 9 cm
36" x 3^{3/5}"

60 x 60 cm
24" x 24"

60 x 9 cm
24" x 3^{3/5}"

45 x 45 cm
17^{3/4}" x 17^{3/4}"

45 x 9 cm
17^{3/4}" x 3^{3/5}"

9 x 9 cm
3^{3/5}" x 3^{3/5}"

SUPERFICI

SURFACES
OBERFLÄCHEN
SURFACES

DI CAVA

DI FABBRICA

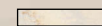
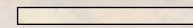
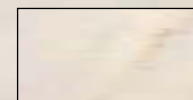

LEVIGATO E LUCIDATO / HONED AND POLISHED /
GESCHLIFFEN UND POLIERT / POLI ET LUSTRÉ

PRELEVIGATO / PREPOLISHED / VORGESCHLIFFEN / PRÉPOLI

PR (R9)

COEFFICIENTE DI ATTRITO

FRICTION COEFFICIENT
REIBUNGSKOEFFIZIENT
COEFFICIENT DE FROTTEMENT

FORMATI / SIZES / FORMATE / FORMATS

PEZZI SPECIALI / TRIMS / FORMTEILE / PIÈCES SPÉCIALES

DECORI E MOSAICI / DECORS AND MOSAICS / DEKORE UND MOSAIKE / DECORS ET MOSAÏQUE

pag. 340

pag. 341

pag. 342

ESTREMOZ

MARMI HIGH-TECH

PROVENIENZA PORTOGALLO

ORIGIN PORTUGAL / HERKUNFT PORTUGAL /
PROVENANCE PORTUGAL

REPERIBILITÀ MODESTA

AVAILABILITY LIMITED /
VERFÜGBARKEIT MÄSSIG /
DISPONIBILITÉ MODÉRÉE

RETTIFICATO MONOCALIBRO

RECTIFIED SINGLE-CALIBRE / REKTIFIZIERT EINKALIBRIG /
RECTIFIÉ MONOCALIBRE

SPESSORE

THICKNESS / DICKE / ÉPAISSEUR

▼
9,5mm
▲

FORMATI

SIZES / FORMATE / FORMATS

120 x 60 cm
48" x 24"



90 x 45 cm
36" x 17^{3/4}"

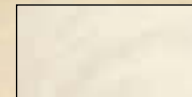

90 x 9 cm
36" x 3^{3/5}"



60 x 60 cm
24" x 24"



60 x 30 cm
24" x 12"

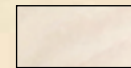

60 x 9 cm
24" x 3^{3/5}"

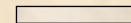

45 x 45 cm
17^{3/4}" x 17^{3/4}"

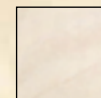

45 x 9 cm
17^{3/4}" x 3^{3/5}"

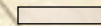

9 x 9 cm
3^{3/5}" x 3^{3/5}"



SUPERFICI

SURFACES
OBERFLÄCHEN
SURFACES

LEVIGATO E LUCIDATO / HONED AND POLISHED /
GESCHLIFFEN UND POLIERT / POLI ET LUSTRÉ

PRELEVIGATO / PREPOLISHED / VORGESCHLIFFEN / PRÉPOLI

COEFFICIENTE DI ATTRITO

FRICTION COEFFICIENT
REIBUNGSKOEFFIZIENT
COEFFICIENT DE FROTTEMENT

PR (R9)

FORMATI / SIZES / FORMATE / FORMATS

PEZZI SPECIALI / TRIMS / FORMTEILE / PIÈCES SPÉCIALES

DECORI E MOSAICI / DECORS AND MOSAICS / DEKORE UND MOSAIKE / DECORS ET MOSAÏQUE

pag. 340

pag. 341

pag. 342

CREMA MARFIL

PROVENIENZA SPAGNA

ORIGIN SPAIN / HERKUNFT SPANIEN /
PROVENANCE ESPAGNE

REPERIBILITÀ BUONA

AVAILABILITY GOOD /
VERFÜGBARKEIT REICHLICH /
DISPONIBILITÉ BONNE

RETTIFICATO MONOCALIBRO

RECTIFIED SINGLE-CALIBRE / REKTIFIZIERT EINKALIBRIG /
RECTIFIÉ MONOCALIBRE

SPESSORE

THICKNESS / DICKE / ÉPAISSEUR

▼
9,5mm
▲

FORMATI

SIZES / FORMATE / FORMATS

120 x 60 cm
48" x 24"

90 x 45 cm
36" x 17^{3/4}"

90 x 9 cm
36" x 3^{3/5}"

60 x 60 cm
24" x 24"

60 x 30 cm
24" x 12"

60 x 9 cm
24" x 3^{3/5}"

45 x 45 cm
17^{3/4}" x 17^{3/4}"

45 x 9 cm
17^{3/4}" x 3^{3/5}"

9 x 9 cm
3^{3/5}" x 3^{3/5}"

SUPERFICI

SURFACES
OBERFLÄCHEN
SURFACES

COEFFICIENTE DI ATTRITO

FRICTION COEFFICIENT
REIBUNGSKOEFFIZIENT
COEFFICIENT DE FROTTEMENT

FORMATI / SIZES / FORMATE / FORMATS

PEZZI SPECIALI / TRIMS / FORMTEILE / PIÈCES SPÉCIALES

DECORI E MOSAICI / DECORS AND MOSAICS / DEKORE UND MOSAIKE / DECORS ET MOSAÏQUE

MARMI HIGH-TECH

DI CAVA

DI FABBRICA

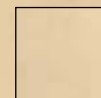
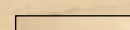
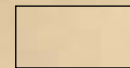
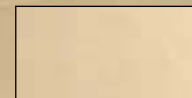

LEVIGATO E LUCIDATO / HONED AND POLISHED /
GESCHLIFFEN UND POLIERT / POLI ET LUSTRÉ

PRELEVIGATO / PREPOLISHED / VORGESCHLIFFEN / PRÉPOLI

PR (R9)

pag. 340

pag. 341

pag. 342



BOTTICINO

PROVENIENZA ITALIA

ORIGIN ITALY / HERKUNFT ITALIEN /
PROVENANCE ITALIE

REPERIBILITÀ BUONA

AVAILABILITY GOOD /
VERFÜGBARKEIT REICHLICH /
DISPONIBILITÉ BONNE

RETTIFICATO MONOCALIBRO

RECTIFIED SINGLE-CALIBRE / REKTIFIZIERT EINKALIBRIG /
RECTIFIÉ MONOCALIBRE

SPESSORE

THICKNESS / DICKE / ÉPAISSEUR

▼
9,5mm
▲

FORMATI

SIZES / FORMATE / FORMATS

60 x 60 cm
24"x 24"



60 x 30 cm
24"x 12"



60 x 9 cm
24"x 3^{3/5}"

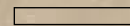

9 x 9 cm
3^{3/5}" x 3^{3/5}"



SUPERFICI

SURFACES
OBERFLÄCHEN
SURFACES

LEVIGATO E LUCIDATO / HONED AND POLISHED /
GESCHLIFFEN UND POLIERT / POLI ET LUSTRÉ

PRELEVIGATO / PREPOLISHED / VORGESCHLIFFEN / PRÉPOLI

COEFFICIENTE DI ATTRITO

FRICTION COEFFICIENT
REIBUNGSKOEFFIZIENT
COEFFICIENT DE FROTTEMENT

PR **(R9)**

FORMATI / SIZES / FORMATE / FORMATS

PEZZI SPECIALI / TRIMS / FORMTEILE / PIÈCES SPÉCIALES

DECORI E MOSAICI / DECORS AND MOSAICS / DEKORE UND MOSAIKE / DECORS ET MOSAÏQUE

pag. 340

pag. 341

pag. 342

MARMI HIGH-TECH

DI CAVA



DI FABBRICA

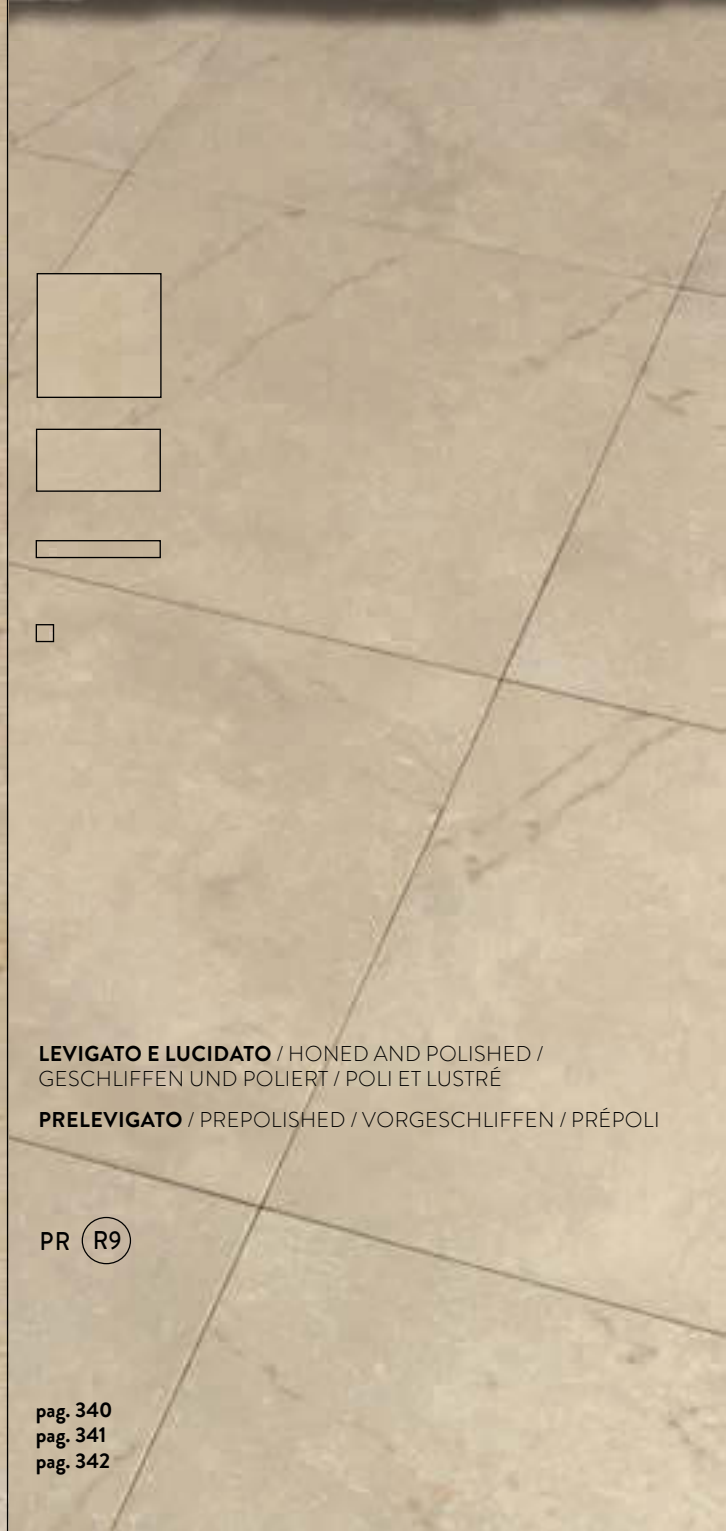

ROSA PORTOGALLO

PROVENIENZA PORTOGALLO

ORIGIN PORTUGAL / HERKUNFT PORTUGAL /
PROVENANCE PORTUGAL

REPERIBILITÀ BUONA

AVAILABILITY GOOD /
VERFÜGBARKEIT REICHLICH /
DISPONIBILITÉ BONNE

RETTIFICATO MONOCALIBRO

RECTIFIED SINGLE-CALIBRE / REKTIFIZIERT EINKALIBRIG /
RECTIFIÉ MONOCALIBRE

SPESSORE

THICKNESS / DICKE / ÉPAISSEUR

▼
9,5mm
▲

FORMATI

SIZES / FORMATE / FORMATS

60 x 60 cm
24" x 24"

60 x 30 cm
24" x 12"

60 x 9 cm
24" x 3^{3/5}"

9 x 9 cm
3^{3/5}" x 3^{3/5}"

SUPERFICI

SURFACES
OBERFLÄCHEN
SURFACES

COEFFICIENTE DI ATTRITO

FRICTION COEFFICIENT
REIBUNGSKOEFFIZIENT
COEFFICIENT DE FROTTEMENT

FORMATI / SIZES / FORMATE / FORMATS

PEZZI SPECIALI / TRIMS / FORMTEILE / PIÈCES SPÉCIALES

DECORI E MOSAICI / DECORS AND MOSAICS / DEKORE UND MOSAIKE / DECORS ET MOSAÏQUE

MARMI HIGH-TECH

DI CAVA

DI FABBRICA

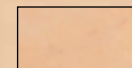

LEVIGATO E LUCIDATO / HONED AND POLISHED /
GESCHLIFFEN UND POLIERT / POLI ET LUSTRÉ

PRELEVIGATO / PREPOLISHED / VORGESCHLIFFEN / PRÉPOLI

PR (R9)

pag. 340

pag. 341

pag. 342

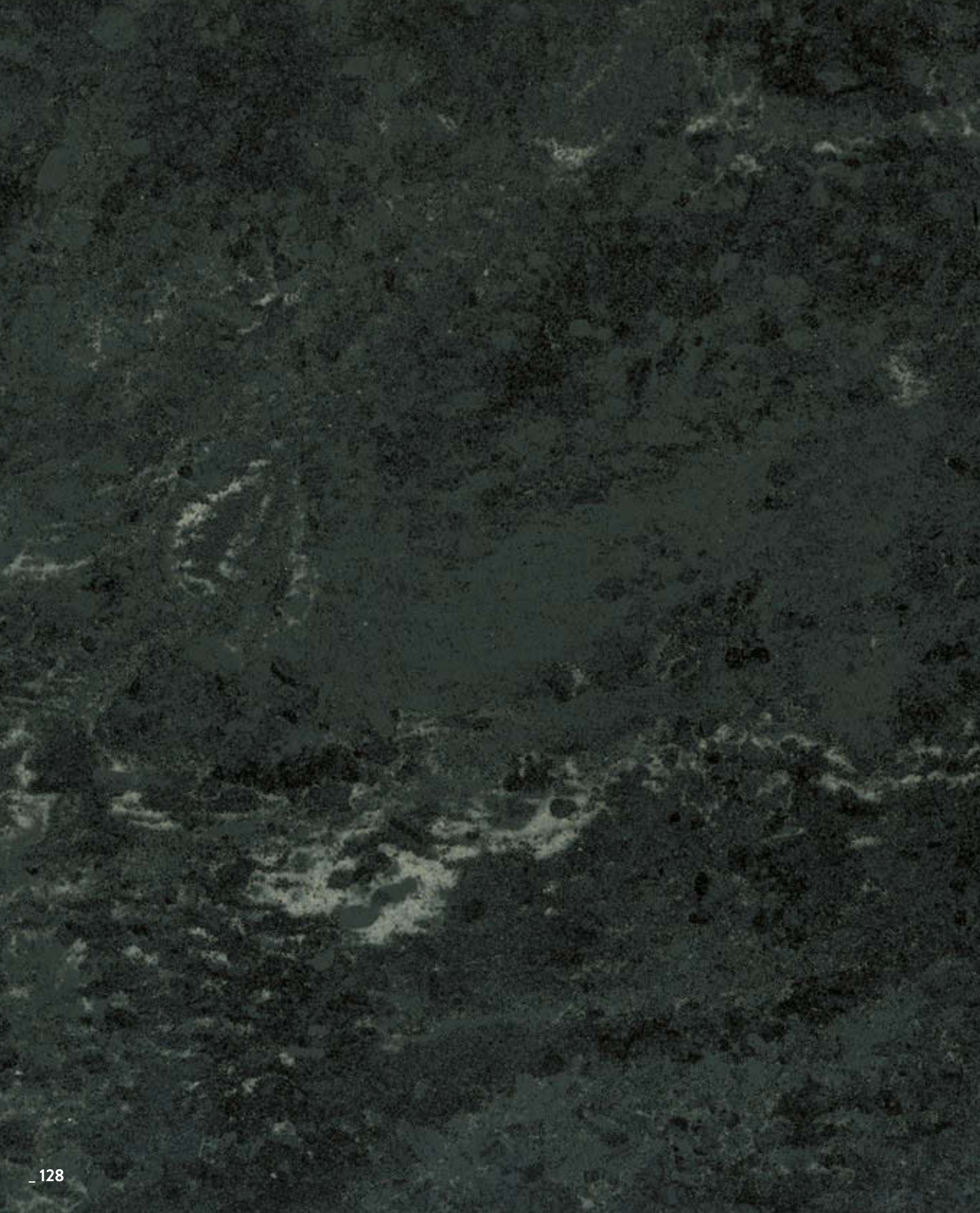

VERDE ALPI

PROVENIENZA ITALIA
ORIGIN ITALY / HERKUNFT ITALIEN /
PROVENANCE ITALIE

REPERIBILITÀ LIMITATA
AVAILABILITY SCARCE /
VERFÜGBARKEIT BEGRENZT /
DISPONIBILITÉ LIMITÉE

RETTIFICATO MONOCALIBRO
RECTIFIED SINGLE-CALIBRE / REKTIFIZIERT EINKALIBRIG /
RECTIFIÉ MONOCALIBRE

SPESSORE
THICKNESS / DICKE / ÉPAISSEUR

9,5mm

FORMATI
SIZES / FORMATE / FORMATS

60 x 60 cm
24" x 24"

60 x 30 cm
24" x 12"

60 x 9 cm
24" x 3^{3/5}"

9 x 9 cm
3^{3/5}" x 3^{3/5}"

SUPERFICI
SURFACES
OBERFLÄCHEN
SURFACES

COEFFICIENTE DI ATTRITO
FRICTION COEFFICIENT
REIBUNGSKOEFFIZIENT
COEFFICIENT DE FROTTEMENT

FORMATI / SIZES / FORMATE / FORMATS
PEZZI SPECIALI / TRIMS / FORMTEILE / PIÈCES SPÉCIALES

DECORI E MOSAICI / DECORS AND MOSAICS / DEKORE UND MOSAIKE / DECORS ET MOSAIQUE

MARMI HIGH-TECH

DI CAVA

DI FABBRICA

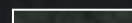

LEVIGATO E LUCIDATO / HONED AND POLISHED /
GESCHLIFFEN UND POLIERT / POLI ET LUSTRÉ

PRELEVIGATO / PREPOLISHED / VORGESCHLIFFEN / PRÉPOLI

PR **R9**

pag. 340

pag. 341

pag. 342

DARK EMPERADOR

PROVENIENZA SPAGNA
ORIGIN SPAIN / HERKUNFT SPANIEN /
PROVENANCE ESPAGNE

REPERIBILITÀ LIMITATA
AVAILABILITY SCARCE /
VERFÜGBARKEIT BEGRENZT /
DISPONIBILITÉ LIMITÉE

RETTIFICATO MONOCALIBRO
RECTIFIED SINGLE-CALIBRE / REKTIFIZIERT EINKALIBRIG /
RECTIFIÉ MONOCALIBRE

SPESSORE
THICKNESS / DICKE / ÉPAISSEUR

9,5mm

FORMATI
SIZES / FORMATE / FORMATS

120 x 60 cm
48" x 24"

60 x 60 cm
24" x 24"

60 x 30 cm
24" x 12"

60 x 9 cm
24" x 3^{3/5}"

9 x 9 cm
3^{3/5}" x 3^{3/5}"

SUPERFICI
SURFACES
OBERFLÄCHEN
SURFACES

COEFFICIENTE DI ATTRITO
FRICTION COEFFICIENT
REIBUNGSKOEFFIZIENT
COEFFICIENT DE FROTTEMENT

FORMATI / SIZES / FORMATE / FORMATS
PEZZI SPECIALI / TRIMS / FORMTEILE / PIÈCES SPÉCIALES

DECORI E MOSAICI / DECORS AND MOSAICS / DEKORE UND MOSAIKE / DECORS ET MOSAIQUE

MARMI HIGH-TECH

DI CAVA

DI FABBRICA



LEVIGATO E LUCIDATO / HONED AND POLISHED /
GESCHLIFFEN UND POLIERT / POLI ET LUSTRÉ

PRELEVIGATO / PREPOLISHED / VORGESCHLIFFEN / PRÉPOLI

PR (R9)

pag. 340

pag. 341

pag. 342

NERO MARQUINIA

PROVENIENZA SPAGNA

ORIGIN SPAIN / HERKUNFT SPANIEN /
PROVENANCE ESPAGNE

REPERIBILITÀ MODESTA

AVAILABILITY LIMITED /
VERFÜGBARKEIT MÄSSIG /
DISPONIBILITÉ MODÉRÉE

RETTIFICATO MONOCALIBRO

RECTIFIED SINGLE-CALIBRE / REKTIFIZIERT EINKALIBRIG /
RECTIFIÉ MONOCALIBRE

SPESSORE

THICKNESS / DICKE / ÉPAISSEUR

9,5mm

FORMATI

SIZES / FORMATE / FORMATS

60 x 60 cm
24" x 24"

60 x 30 cm
24" x 12"

60 x 9 cm
24" x 3³/₅"

9 x 9 cm
3³/₅" x 3³/₅"

SUPERFICI

SURFACES
OBERFLÄCHEN
SURFACES

COEFFICIENTE DI ATTRITO

FRICTION COEFFICIENT
REIBUNGSKOEFFIZIENT
COEFFICIENT DE FROTTEMENT

FORMATI / SIZES / FORMATE / FORMATS

PEZZI SPECIALI / TRIMS / FORMTEILE / PIÈCES SPÉCIALES

DECORI E MOSAICI / DECORS AND MOSAICS / DEKORE UND MOSAIKE / DECORS ET MOSAIQUE

MARMI HIGH-TECH

DI CAVA

DI FABBRICA

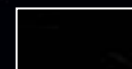
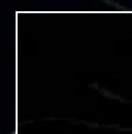

LEVIGATO E LUCIDATO / HONED AND POLISHED /
GESCHLIFFEN UND POLIERT / POLI ET LUSTRÉ

PRELEVIGATO / PREPOLISHED / VORGESCHLIFFEN / PRÉPOLI

PR (R9)

pag. 340

pag. 341

pag. 342

PIETRA DI CALAIS	136
PIETRA DI BRUGGE	138
PIETRA DI ESSEN	140
PIETRA DI UTRECHT	142
PIETRA DI ROUBAIX	144
QUARZITE BIANCA	146
LIMRA	148
CREMA EUROPA	150
PIETRA DI BARGE	152
PIETRA GIALLA	154
GREEN QUARZITE	156
PIETRA SINTRA	158
TRAVERTINO CHIARO	160
PIETRA DI BORGOGNA	162
TRAVERTINO NOCE	164
SILK GEORGETTE	166
PIETRA PIASENTINA	168
ARDESIA BORDEAUX	170
PIETRA DI MERANO	172
PIETRA DELL'ESTEREL	174
PIETRA D'AVOLA	176
PIETRA DI RAGUSA	178
PIETRA DI LUSERNA	180
SILVER GREY	182
BASALTO GRIGIO	184
ARDESIA ANTRACITE	186
BLACK ARDESIA	188
CADAPPA BLACK	190

PIETRE NATURALI HIGH-TECH

PIETRE NATURALI HIGH-TECH & INNOVATIVE SLABS

150X75

PIETRA DI CALAIS

INNOVATIVE SLABS

PROVENIENZA BELGIO

ORIGIN BELGIUM / HERKUNFT BELGIEN /
PROVENANCE BELGIQUE

REPERIBILITÀ LIMITATA

AVAILABILITY SCARCE /
VERFÜGBARKEIT BEGRENZT /
DISPONIBILITÉ LIMITÉE

RETTIFICATO MONOCALIBRO

RECTIFIED SINGLE-CALIBRE / REKTIFIZIERT EINKALIBRIG /
RECTIFIÉ MONOCALIBRE

SPESSORE

THICKNESS / DICKE / ÉPAISSEUR

10mm

ACTIVE

FORMATI

SIZES / FORMATE / FORMATS

150 x 75 cm

60" x 30"

75 x 75 cm

30" x 30"

75 x 37,5 cm

30" x 15"

SUPERFICI

SURFACES
OBERFLÄCHEN
SURFACES

STRUTTURATO / STRUCTURED / STRUKTURIERT / STRUCTURÉ

SOFT

ANTICATO / ANTIQUED / ANTIK / ANTIQUE

COEFFICIENTE DI ATTRITO

FRICTION COEFFICIENT
REIBUNGSKOEFFIZIENT
COEFFICIENT DE FROTTEMENT

ST (R11) A+B+C

SO (R10) A+B

AN (R9) A

FORMATI / SIZES / FORMATE / FORMATS

PEZZI SPECIALI / TRIMS / FORMTEILE / PIÈCES SPÉCIALES

DECORI E MOSAICI / DECORS AND MOSAICS / DEKORE UND MOSAIKE / DECORS ET MOSAÏQUE

pag. 344

pag. 346

pag. 348

150X75

PIETRA DI BRUGGE

INNOVATIVE SLABS

PROVENIENZA BELGIO
ORIGIN BELGIUM / HERKUNFT BELGIEN /
PROVENANCE BELGIQUE

REPERIBILITÀ LIMITATA
AVAILABILITY SCARCE /
VERFÜGBARKEIT BEGRENZT /
DISPONIBILITÉ LIMITÉE

RETTIFICATO MONOCALIBRO
RECTIFIED SINGLE-CALIBRE / REKTIFIZIERT EINKALIBRIG /
RECTIFIÉ MONOCALIBRE

SPESSORE
THICKNESS / DICKE / ÉPAISSEUR

▼
10mm
▲

ACTIVE

FORMATI
SIZES / FORMATE / FORMATS

150 x 75 cm
60" x 30"

75 x 75 cm
30" x 30"

75 x 37,5 cm
30" x 15"

SUPERFICI
SURFACES
OBERFLÄCHEN
SURFACES

COEFFICIENTE DI ATTRITO
FRICTION COEFFICIENT
REIBUNGSKOEFFIZIENT
COEFFICIENT DE FROTTEMENT

FORMATI / SIZES / FORMATE / FORMATS

PEZZI SPECIALI / TRIMS / FORMTEILE / PIÈCES SPÉCIALES

DECORI E MOSAICI / DECORS AND MOSAICS / DEKORE UND MOSAIKE / DECORS ET MOSAÏQUE

DI FABBRICA



STRUTTURATO / STRUCTURED / STRUKTURIERT / STRUCTURÉ

SOFT

ANTICATO / ANTIQUED / ANTIK / ANTIQUE

ST (R11) A+B+C

SO (R10) A+B

AN (R9) A

pag. 344

pag. 346

pag. 348

150X75

PIETRA DI ESSEN

INNOVATIVE SLABS

PROVENIENZA FRANCIA
ORIGIN FRANCE / HERKUNFT FRANKREICH /
PROVENANCE FRANCE

REPERIBILITÀ BUONA
AVAILABILITY GOOD /
VERFÜGBARKEIT REICHLICH /
DISPONIBILITÉ BONNE

RETTIFICATO MONOCALIBRO
RECTIFIED SINGLE-CALIBRE / REKTIFIZIERT EINKALIBRIG /
RECTIFIÉ MONOCALIBRE

SPESSORE
THICKNESS / DICKE / ÉPAISSEUR

10mm

FORMATI
SIZES / FORMATE / FORMATS

150 x 75 cm
60" x 30"

75 x 75 cm
30" x 30"

75 x 37,5 cm
30" x 15"

SUPERFICI
SURFACES
OBERFLÄCHEN
SURFACES

COEFFICIENTE DI ATTRITO
FRICTION COEFFICIENT
REIBUNGSKOEFFIZIENT
COEFFICIENT DE FROTTEMENT

FORMATI / SIZES / FORMATE / FORMATS

PEZZI SPECIALI / TRIMS / FORMTEILE / PIÈCES SPÉCIALES

DECORI E MOSAICI / DECORS AND MOSAICS / DEKORE UND MOSAIKE / DECORS ET MOSAÏQUE

DI FABBRICA



STRUTTURATO / STRUCTURED / STRUKTURIERT / STRUCTURÉ
SOFT

ANTICATO / ANTIQUED / ANTIK / ANTIQUE

ST (R11) A+B+C

SO (R10) A+B

AN (R9) A

pag. 344

pag. 346

pag. 348

150X75

PIETRA DI UTRECHT

PROVENIENZA FRANCIA
ORIGIN FRANCE / HERKUNFT FRANKREICH /
PROVENANCE FRANCE

REPERIBILITÀ BUONA
AVAILABILITY GOOD /
VERFÜGBARKEIT REICHLICH /
DISPONIBILITÉ BONNE

RETTIFICATO MONOCALIBRO
RECTIFIED SINGLE CALIBRE / REKTIFIZIERT EINKALBRIG /
RECTIFIÉ MONOCALIBRE

SPESSORE
THICKNESS / DICKE / ÉPAISSEUR

10mm

FORMATI
SIZES / FORMATE / FORMATS

150 x 75 cm
60" x 30"

75 x 75 cm
30" x 30"

75 x 37,5 cm
30" x 15"

SUPERFICI
SURFACES
OBERFLÄCHEN
SURFACES

COEFFICIENTE DI ATTRITO
FRICTION COEFFICIENT
REIBUNGSKOEFFIZIENT
COEFFICIENT DE FROTTEMENT

FORMATI / SIZES / FORMATE / FORMATS

PEZZI SPECIALI / TRIMS / FORMTEILE / PIÈCES SPÉCIALES

DECORI E MOSAICI / DECORS AND MOSAICS / DEKORE UND MOSAIKE / DÉCORS ET MOSAÏQUE

INNOVATIVE SLABS

DI FABBRICA



STRUTTURATO / STRUCTURED / STRUKTURIERT / STRUCTURÉ

SOFT

ANTICATO / ANTIQUED / ANTIK / ANTIQUE

ST (R11) A+B+C

SO (R10) A+B

AN (R9) A

pag. 344

pag. 346

pag. 348

PIETRA DI ROUBAIX

PROVENIENZA FRANCIA

ORIGIN FRANCE / HERKUNFT FRANKREICH /
PROVENANCE FRANCE

REPERIBILITÀ BUONA

AVAILABILITY GOOD /
VERFÜGBARKEIT REICHLICH /
DISPONIBILITÉ BONNE

RETTIFICATO MONOCALIBRO

RECTIFIED SINGLE-CALIBRE / REKTIFIZIERT EINKALIBRIG /
RECTIFIÉ MONOCALIBRE

SPESSORE

THICKNESS / DICKE / ÉPAISSEUR

10mm

FORMATI

SIZES / FORMATE / FORMATS

150 x 75 cm

60" x 30"

75 x 75 cm

30" x 30"

75 x 37,5 cm

30" x 15"

SUPERFICI

SURFACES
OBERFLÄCHEN
SURFACES

COEFFICIENTE DI ATTRITO

FRICTION COEFFICIENT
REIBUNGSKOEFFIZIENT
COEFFICIENT DE FROTTEMENT

FORMATI / SIZES / FORMATE / FORMATS

PEZZI SPECIALI / TRIMS / FORMTEILE / PIÈCES SPÉCIALES

DECORI E MOSAICI / DECORS AND MOSAICS / DEKORE UND MOSAIKE / DECORS ET MOSAÏQUE

INNOVATIVE SLABS

DI FABBRICA

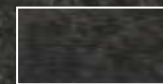

STRUTTURATO / STRUCTURED / STRUKTURIERT / STRUCTURÉ

SOFT

ANTICATO / ANTIQUED / ANTIK / ANTIQUE

ST (R11) A+B+C

SO (R10) A+B

AN (R9) A

pag. 344

pag. 346

pag. 348

QUARZITE BIANCA

PROVENIENZA ARABIA SAUDITA
ORIGIN SAUDI ARABIA / HERKUNFT SAUDI-ARABIEN /
PROVENANCE ARABIE SAOUDITE

REPERIBILITÀ BUONA
AVAILABILITY GOOD /
VERFÜGBARKEIT REICHLICH /
DISPONIBILITÉ BONNE

RETTIFICATO MONOCALIBRO
RECTIFIED SINGLE-CALIBRE / REKTIFIZIERT EINKALIBRIG /
RECTIFIÉ MONOCALIBRE

SPESSORE
THICKNESS / DICKE / ÉPAISSEUR

▼
10mm
▲

ACTIVE



FORMATI
SIZES / FORMATE / FORMATS

120 x 60 cm
48" x 24"



60 x 60 cm
24" x 24"

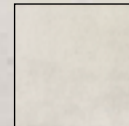

60 x 30 cm
24" x 12"

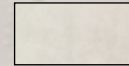

60 x 15 cm
24" x 6"

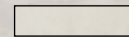

60 x 10 cm
24" x 4"



SUPERFICI
SURFACES
OBERFLÄCHEN
SURFACES

STRUTTURATO / STRUCTURED / STRUKTURIERT / STRUCTURÉ
SEMILUCIDATO / SEMI-POLISHED / SEMI-MATT / SEMI-LUSTRÉ

COEFFICIENTE DI ATTRITO
FRICTION COEFFICIENT
REIBUNGSKOEFFIZIENT
COEFFICIENT DE FROTTEMENT

ST (R11) A+B+C

SL (R10) A

GREENSTONE

DI FABBRICA

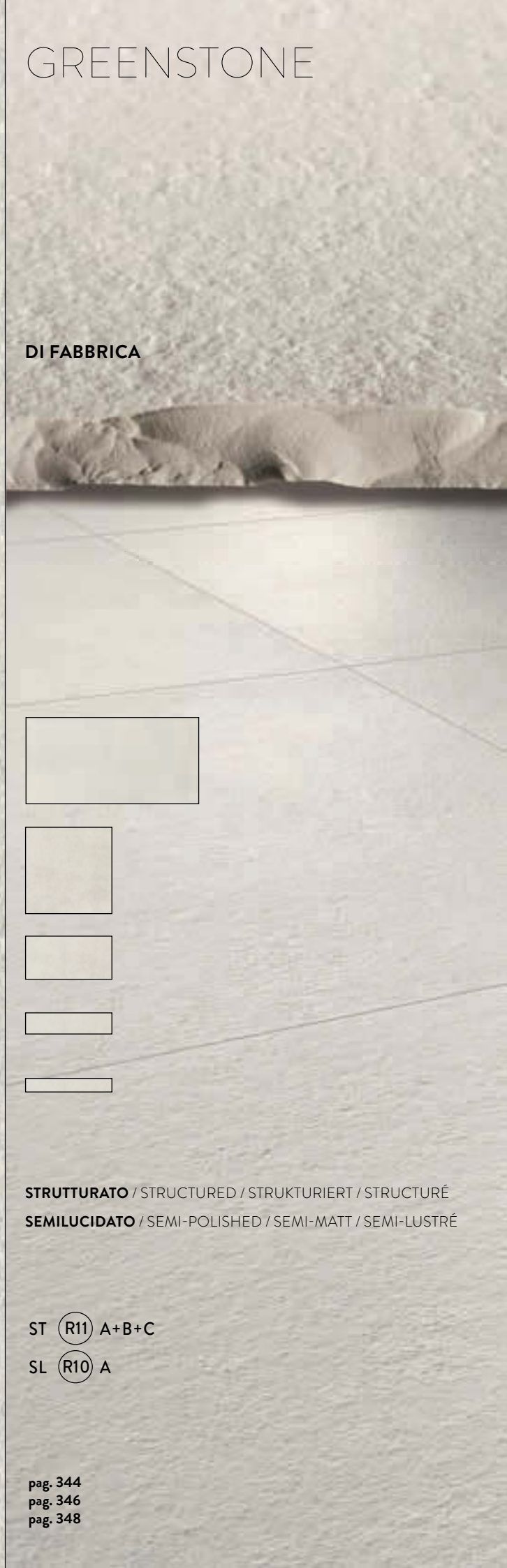

LIMRA

PIETRE NATURALI HIGH-TECH

PROVENIENZA TURCHIA

ORIGIN TURKEY / HERKUNFT TÜRKEI /
PROVENANCE TURQUIE

REPERIBILITÀ MODESTA

AVAILABILITY SCARCE /
VERFÜGBARKEIT BESCHEIDEN /
DISPONIBILITÉ MODESTE

RETTIFICATO MONOCALIBRO

RECTIFIED SINGLE-CALIBRE / REKTIFIZIERT EINKALBRIG /
RECTIFIÉ MONOCALIBRE

SPESSORE

THICKNESS / DICKE / ÉPAISSEUR

▼
10mm
▲

FORMATI

SIZES / FORMATE / FORMATS

120 x 60 cm
48" x 24"

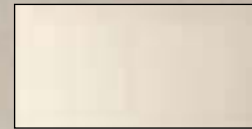

90 x 45 cm
36" x 17^{3/4}"

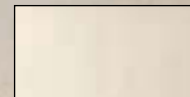

90 x 90 cm
36" x 36"



60 x 60 cm
24" x 24"



60 x 30 cm
24" x 12"

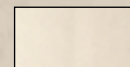

60 x 15 cm
24" x 6"

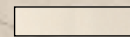

60 x 10 cm
24" x 4"

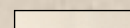

SUPERFICI

SURFACES
OBERFLÄCHEN
SURFACES

STRUTTURATO / STRUCTURED / STRUKTURIERT / STRUCTURÉ

SATINATO / SATIN-FINISH / SATINIERT / SATINÉ

COEFFICIENTE DI ATTRITO

FRICTION COEFFICIENT
REIBUNGSKOEFFIZIENT
COEFFICIENT DE FROTTEMENT

ST (R11) A+B+C

SA (R10) A+B

FORMATI / SIZES / FORMATE / FORMATS

PEZZI SPECIALI / TRIMS / FORMTEILE / PIÈCES SPÉCIALES

DECORI E MOSAICI / DECORS AND MOSAICS / DEKORE UND MOSAIKE / DECORS ET MOSAÏQUE

pag. 344

pag. 346

pag. 348

CREMA EUROPA

PIETRE NATURALI HIGH-TECH

PROVENIENZA FRANCIA

ORIGIN FRANCE / HERKUNFT FRANKREICH /
PROVENANCE FRANCE

REPERIBILITÀ BUONA

AVAILABILITY GOOD /
VERFÜGBARKEIT REICHLICH /
DISPONIBILITÉ BONNE

RETTIFICATO MONOCALIBRO

RECTIFIED SINGLE-CALIBRE / REKTIFIZIERT EINKALIBRIG /
RECTIFIÉ MONOCALIBRE

SPESSORE

THICKNESS / DICKE / ÉPAISSEUR

10mm

cm²

FORMATI

SIZES / FORMATE / FORMATS

120 x 60 cm
48" x 24"



90 x 45 cm
36" x 17^{3/4}"



90 x 9 cm
36" x 3^{3/5}"



60 x 60 cm
24" x 24"



60 x 30 cm
24" x 12"

60 x 15 cm
24" x 6"



60 x 10 cm
24" x 4"

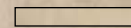

30 x 30 cm
12" x 12"



30 x 15 cm
12" x 6"



15 x 15 cm
6" x 6"



SUPERFICI

SURFACES
OBERFLÄCHEN
SURFACES

STRUTTURATO / STRUCTURED / STRUKTURIERT / STRUCTURÉ

SATINATO / SATIN-FINISH / SATINIERT / SATINÉ

HIGH HONED

COEFFICIENTE DI ATTRITO

FRICITION COEFFICIENT
REIBUNGSKOEFFIZIENT
COEFFICIENT DE FROTTEMENT

ST (R11) A+B

SA (R9)

FORMATI / SIZES / FORMATE / FORMATS

PEZZI SPECIALI / TRIMS / FORMTEILE / PIÈCES SPÉCIALES

DECORI E MOSAICI / DECORS AND MOSAICS / DEKORE UND MOSAIKE / DECORS ET MOSAÏQUE

pag. 344

pag. 346

pag. 348

PIETRA DI BARGE

PIETRE NATURALI HIGH-TECH

PROVENIENZA BRASILE

ORIGIN BRAZIL / HERKUNFT BRASIL /
PROVENANCE BRÉSIL

REPERIBILITÀ ESTREMAMENTE LIMITATA

AVAILABILITY VERY SCARCE /
VERFÜGBARKEIT ÄUSSERST BEGRENZT /
DISPONIBILITÉ EXTRÊ MEMENT LIMITÉE

RETTIFICATO MONOCALIBRO

RECTIFIED SINGLE-CALIBRE / REKTIFIZIERT EINKALIBRIG /
RECTIFIÉ MONOCALIBRE

SPESSORE

THICKNESS / DICKE / ÉPAISSEUR

▼
10mm
▲

DI FABBRICA

FORMATI

SIZES / FORMATE / FORMATS

60 x 60 cm
24" x 24"



60 x 30 cm
24" x 12"



60 x 15 cm
24" x 6"



60 x 10 cm
24" x 4"

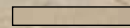

30 x 30 cm
12" x 12"



30 x 15 cm
12" x 6"



15 x 15 cm
6" x 6"



SUPERFICI

SURFACES
OBERFLÄCHEN
SURFACES

STRUTTURATO / STRUCTURED / STRUKTURIERT / STRUCTURÉ

SATINATO / SATIN-FINISH / SATINIERT / SATINÉ

COEFFICIENTE DI ATTRITO

FRICTION COEFFICIENT
REIBUNGSKOEFFIZIENT
COEFFICIENT DE FROTTEMENT

ST **(R11)** A+B

SA **(R9)**

FORMATI / SIZES / FORMATE / FORMATS

PEZZI SPECIALI / TRIMS / FORMTEILE / PIÈCES SPÉCIALES

DECORI E MOSAICI / DECORS AND MOSAICS / DEKORE UND MOSAIKE / DECORS ET MOSAÏQUE

pag. 344

pag. 346

pag. 348

PIETRA GIALLA

PROVENIENZA GERMANIA
ORIGIN GERMANY / HERKUNFT DEUTSCHLAND /
PROVENANCE ALLEMAGNE

REPERIBILITÀ BUONA
AVAILABILITY GOOD /
VERFÜGBARKEIT REICHLICH /
DISPONIBILITÉ BONNE

RETTIFICATO MONOCALIBRO
RECTIFIED SINGLE-CALIBRE / REKTIFIZIERT EINKALIBRIG /
RECTIFIÉ MONOCALIBRE

SPESSORE
THICKNESS / DICKE / ÉPAISSEUR

▼
10mm
▲

FORMATI
SIZES / FORMATE / FORMATS

60 x 30 cm
24" x 12"

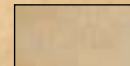

60 x 15 cm
24" x 6"



60 x 10 cm
24" x 4"



30 x 30 cm
12" x 12"



30 x 15 cm
12" x 6"



15 x 15 cm
6" x 6"



SUPERFICI
SURFACES
OBERFLÄCHEN
SURFACES

STRUTTURATO / STRUCTURED / STRUKTURIERT / STRUCTURÉ

SATINATO / SATIN-FINISH / SATINIERT / SATINÉ

COEFFICIENTE DI ATTRITO
FRICTION COEFFICIENT
REIBUNGSKOEFFIZIENT
COEFFICIENT DE FROTTEMENT

ST **(R11)** A+B

SA **(R9)**

FORMATI / SIZES / FORMATE / FORMATS
PEZZI SPECIALI / TRIMS / FORMTEILE / PIÈCES SPÉCIALES
DECORI E MOSAICI / DECORS AND MOSAICS / DEKORE UND MOSAIKE / DECORS ET MOSAÏQUE

pag. 344
pag. 346
pag. 348

PIETRE NATURALI HIGH-TECH

DI FABBRICA

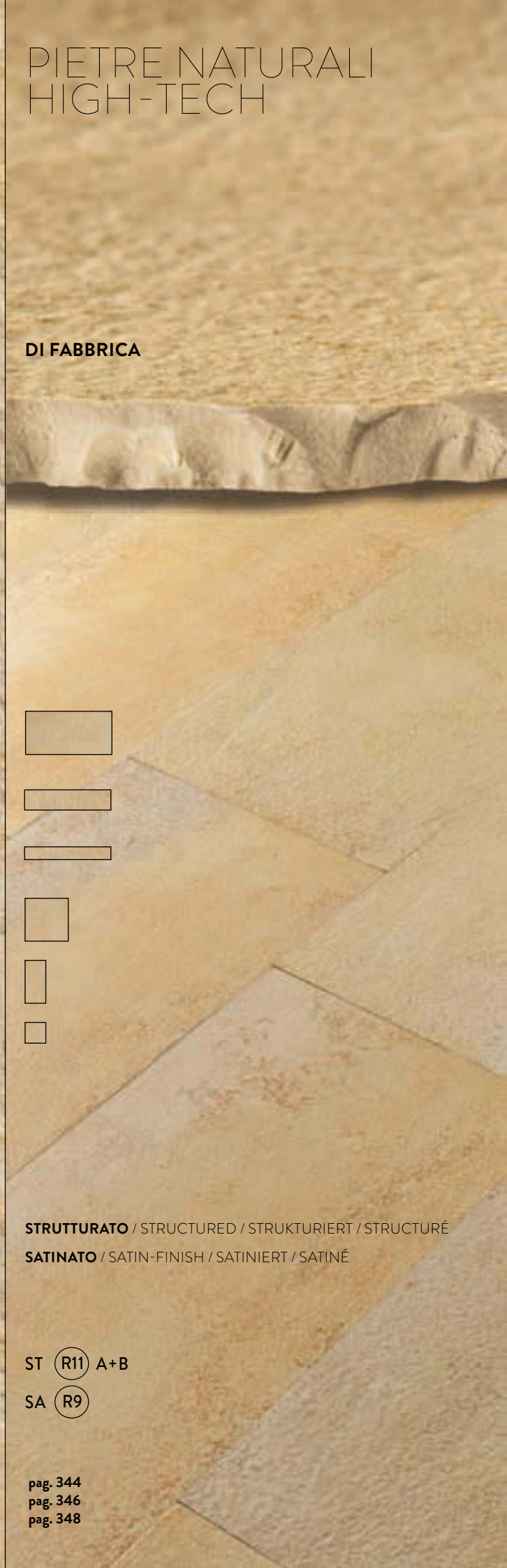



GREEN QUARZITE

PIETRE NATURALI
HIGH-TECH

PROVENIENZA URUGUAY

ORIGIN URUGUAY / HERKUNFT URUGUAY /
PROVENANCE URUGUAY

REPERIBILITÀ BUONA

AVAILABILITY GOOD /
VERFÜGBARKEIT REICHLICH /
DISPONIBILITÉ BONNE

RETTIFICATO MONOCALIBRO

RECTIFIED SINGLE-CALIBRE / REKTIFIZIERT EINKALIBRIG /
RECTIFIÉ MONOCALIBRE

SPESSORE

THICKNESS / DICKE / ÉPAISSEUR

▼
10mm
▲

▲
cm2
▼

FORMATI

SIZES / FORMATE / FORMATS

60 x 60 cm
24"x 24"

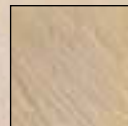

60 x 30 cm
24"x 12"



60 x 15 cm
24"x 6"

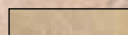

60 x 10 cm
24"x 4"

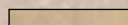

30 x 30 cm
12"x 12"



30 x 15 cm
12"x 6"



15 x 15 cm
6"x 6"



SUPERFICI

SURFACES
OBERFLÄCHEN
SURFACES

STRUTTURATO / STRUCTURED / STRUKTURIERT / STRUCTURÉ

COEFFICIENTE DI ATTRITO

FRICTION COEFFICIENT
REIBUNGSKOEFFIZIENT
COEFFICIENT DE FROTTEMENT

ST **(R10)** A+B

FORMATI / SIZES / FORMATE / FORMATS

PEZZI SPECIALI / TRIMS / FORMTEILE / PIÈCES SPÉCIALES

DECORI E MOSAICI / DECORS AND MOSAICS / DEKORE UND MOSAIKE / DECORS ET MOSAÏQUE

pag. 344

pag. 346

pag. 348

PIETRA SINTRA

GREENSTONE

PROVENIENZA PORTOGALLO
ORIGIN PORTUGAL / HERKUNFT PORTUGAL /
PROVENANCE PORTUGAL

REPERIBILITÀ BUONA
AVAILABILITY GOOD /
VERFÜGBARKEIT REICHLICH /
DISPONIBILITÉ BONNE

RETTIFICATO MONOCALIBRO
RECTIFIED SINGLE-CALIBRE / REKTIFIZIERT EINKALIBRIG /
RECTIFIÉ MONOCALIBRE

SPESSORE
THICKNESS / DICKE / ÉPAISSEUR

▼
10mm
▲

ACTIVE



FORMATI
SIZES / FORMATE / FORMATS

120 x 60 cm
48" x 24"



60 x 60 cm
24" x 24"



60 x 30 cm
24" x 12"

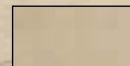

60 x 15 cm
24" x 6"



60 x 10 cm
24" x 4"



SUPERFICI
SURFACES
OBERFLÄCHEN
SURFACES

STRUTTURATO / STRUCTURED / STRUKTURIERT / STRUCTURÉ
SEMILUCIDATO / SEMI-POLISHED / SEMI-MATT / SEMI-LUSTRÉ

COEFFICIENTE DI ATTRITO
FRICTION COEFFICIENT
REIBUNGSKOEFFIZIENT
COEFFICIENT DE FROTTEMENT

ST (R11) A+B+C

SL (R10) A



stone innovation

Il nome Travertino Chiaro e la finitura sono repliche dell'originale in pietra naturale studiate e realizzate dalla Salvatori marmi e riprodotte su gentile concessione.

www.salvatori.it

The name Travertino Chiaro and finishing are replicas of the original natural stone designed and manufactured by Salvatori marbles and reproduced by kind concession.

www.salvatori.it

TRAVERTINO CHIARO

PIETRE NATURALI HIGH-TECH

PROVENIENZA ITALIA

ORIGIN ITALY / HERKUNFT ITALIEN /
PROVENANCE ITALIE

REPERIBILITÀ BUONA

AVAILABILITY GOOD /
VERFÜGBARKEIT REICHLICH /
DISPONIBILITÉ BONNE

RETTIFICATO MONOCALIBRO

RECTIFIED SINGLE-CALIBRE / REKTIFIZIERT EINKALIBRIG /
RECTIFIÉ MONOCALIBRE

SPESSORE

THICKNESS / DICKE / ÉPAISSEUR

10 mm

FORMATI

SIZES / FORMATE / FORMATS

120 x 60 cm
48" x 24"



120 x 30 cm
48" x 12"



60 x 60 cm
24" x 24"



60 x 30 cm
24" x 12"



SUPERFICI

SURFACES
OBERFLÄCHEN
SURFACES

NATURALE / NATURAL / NATURBELASSEN / NATUREL

BAMBOO

COEFFICIENTE DI ATTRITO

FRICTION COEFFICIENT
REIBUNGSKOEFFIZIENT
COEFFICIENT DE FROTTEMENT

N (R10) A

BA (R12) A+B+C

FORMATI / SIZES / FORMATE / FORMATS

PEZZI SPECIALI / TRIMS / FORMTEILE / PIÈCES SPÉCIALES

DECORI E MOSAICI / DECORS AND MOSAICS / DEKORE UND MOSAIKE / DECORS ET MOSAÏQUE

pag. 344

pag. 346

pag. 348

PIETRA DI BORGOGNA

PIETRE NATURALI HIGH-TECH

PROVENIENZA FRANCIA

ORIGIN FRANCE / HERKUNFT FRANKREICH /
PROVENANCE FRANCE

REPERIBILITÀ LIMITATA

AVAILABILITY SCARCE /
VERFÜGBARKEIT BEGRENZT /
DISPONIBILITÉ LIMITÉE

RETTIFICATO MONOCALIBRO

RECTIFIED SINGLE-CALIBRE / REKTIFIZIERT EINKALBRIG /
RECTIFIÉ MONOCALIBRE

SPESSORE

THICKNESS / DICKE / ÉPAISSEUR

▼
10mm
▲

DI FABBRICA

FORMATI

SIZES / FORMATE / FORMATS

90 x 45 cm

36" x 17^{3/4}"

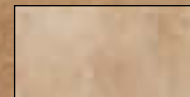

90 x 9 cm

36" x 3^{3/5}"



60 x 60 cm

24" x 24"



60 x 30 cm

24" x 12"



60 x 15 cm

24" x 6"



60 x 10 cm

24" x 4"

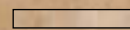

SUPERFICI

SURFACES
OBERFLÄCHEN
SURFACES

STRUTTURATO / STRUCTURED / STRUKTURIERT / STRUCTURÉ

SATINATO / SATIN-FINISH / SATINIERT / SATINÉ

COEFFICIENTE DI ATTRITO

FRICTION COEFFICIENT
REIBUNGSKOEFFIZIENT
COEFFICIENT DE FROTTEMENT

ST **(R11)** A+B+C

SA **(R10)** A+B+C

FORMATI / SIZES / FORMATE / FORMATS

PEZZI SPECIALI / TRIMS / FORMTEILE / PIÈCES SPÉCIALES

DECORI E MOSAICI / DECORS AND MOSAICS / DEKORE UND MOSAIKE / DECORS ET MOSAÏQUE

pag. 344

pag. 346

pag. 348



Il nome Travertino Noce e la finitura Bamboo sono repliche dell'originale in pietra naturale studiate e realizzate dalla Salvatori marmi e riprodotte su gentile concessione.

www.salvatori.it

The name Travertino Noce and finishing Bamboo are replicas of the original natural stone designed and manufactured by Salvatori marbles and reproduced by kind concession.

www.salvatori.it

TRAVERTINO NOCE

PROVENIENZA ITALIA
ORIGIN ITALY / HERKUNFT ITALIEN /
PROVENANCE ITALIE

REPERIBILITÀ MODESTA
AVAILABILITY SCARCE /
VERFÜGBARKEIT BESCHEIDEN /
DISPONIBILITÉ MODESTE

RETTIFICATO MONOCALIBRO
RECTIFIED SINGLE-CALIBRE / REKTIFIZIERT EINKALIBRIG /
RECTIFIÉ MONOCALIBRE

SPESSORE
THICKNESS / DICKE / ÉPAISSEUR

▼
10mm
▲

FORMATI
SIZES / FORMATE / FORMATS

120 x 60 cm
48" x 24"

120 x 30 cm
48" x 12"

60 x 60 cm
24" x 24"

60 x 30 cm
24" x 12"

SUPERFICI
SURFACES
OBERFLÄCHEN
SURFACES

COEFFICIENTE DI ATTRITO
FRICTION COEFFICIENT
REIBUNGSKOEFFIZIENT
COEFFICIENT DE FROTTEMENT

FORMATI / SIZES / FORMATE / FORMATS
PEZZI SPECIALI / TRIMS / FORMTEILE / PIÈCES SPÉCIALES

DECORI E MOSAICI / DECORS AND MOSAICS / DEKORE UND MOSAIKE / DECORS ET MOSAÏQUE

PIETRE NATURALI HIGH-TECH

DI FABBRICA



NATURALE / NATURAL / NATURBELASSEN / NATUREL

BAMBOO

BA (R12) A+B+C

pag. 344
pag. 346
pag. 348

BAMBOO



stone innovation

Il nome Silk Georgette e la finitura Bamboo sono repliche dell'originale in pietra naturale studiate e realizzate dalla Salvatori marmi e riprodotte su gentile concessione.

www.salvatori.it

The name Silk Georgette and finishing Bamboo are replicas of the original natural stone designed and manufactured by Salvatori marbles and reproduced by kind concession.

www.salvatori.it

SILK GEORGETTE

PROVENIENZA MESSICO
ORIGIN MEXICO / HERKUNFT MEXIKO /
PROVENANCE MEXIQUE

REPERIBILITÀ MODESTA
AVAILABILITY SCARCE /
VERFÜGBARKEIT BESCHEIDEN /
DISPONIBILITÉ MODESTE

RETTIFICATO MONOCALIBRO
RECTIFIED SINGLE-CALIBRE / REKTIFIZIERT EINKALIBRIG /
RECTIFIÉ MONOCALIBRE

SPESSORE
THICKNESS / DICKE / ÉPAISSEUR

▼
10mm
▲

FORMATI
SIZES / FORMATE / FORMATS

120 x 60 cm
48" x 24"

120 x 30 cm
48" x 12"

60 x 60 cm
24" x 24"

60 x 30 cm
24" x 12"

SUPERFICI
SURFACES
OBERFLÄCHEN
SURFACES

COEFFICIENTE DI ATTRITO
FRICTION COEFFICIENT
REIBUNGSKOEFFIZIENT
COEFFICIENT DE FROTTEMENT

FORMATI / SIZES / FORMATE / FORMATS

PEZZI SPECIALI / TRIMS / FORMTEILE / PIÈCES SPÉCIALES

DECORI E MOSAICI / DECORS AND MOSAICS / DEKORE UND MOSAIKE / DECORS ET MOSAÏQUE

PIETRE NATURALI HIGH-TECH

DI FABBRICA

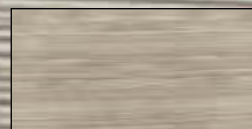

NATURALE / NATURAL / NATURBELASSEN / NATUREL
BAMBOO

N (R9) A+B

BA (R12) A+B+C

pag. 344

pag. 346

pag. 348

BAMBOO

PIETRA PIASENTINA

PIETRE NATURALI HIGH-TECH

PROVENIENZA ITALIA

ORIGIN ITALY / HERKUNFT ITALIEN /
PROVENANCE ITALIE

REPERIBILITÀ BUONA

AVAILABILITY GOOD /
VERFÜGBARKEIT REICHLICH /
DISPONIBILITÉ BONNE

RETTIFICATO MONOCALIBRO

RECTIFIED SINGLE-CALIBRE / REKTIFIZIERT EINKALIBRIG /
RECTIFIÉ MONOCALIBRE

SPESSORE

THICKNESS / DICKE / ÉPAISSEUR

10mm

cm²

FORMATI

SIZES / FORMATE / FORMATS

120 x 60 cm
48" x 24"



60 x 60 cm
24" x 24"



60 x 30 cm
24" x 12"



60 x 15 cm
24" x 6"

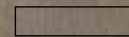

60 x 10 cm
24" x 4"



30 x 30 cm
12" x 12"



30 x 15 cm
12" x 6"



15 x 15 cm
6" x 6"



SUPERFICI

SURFACES
OBERFLÄCHEN
SURFACES

STRUTTURATO / STRUCTURED / STRUKTURIERT / STRUCTURÉ

SATINATO / SATIN-FINISH / SATINIERT / SATINÉ

COEFFICIENTE DI ATTRITO

FRICTION COEFFICIENT
REIBUNGSKOEFFIZIENT
COEFFICIENT DE FROTTEMENT

ST (R11) A+B

SA (R9)

FORMATI / SIZES / FORMATE / FORMATS

PEZZI SPECIALI / TRIMS / FORMTEILE / PIÈCES SPÉCIALES

DECORI E MOSAICI / DECORS AND MOSAICS / DEKORE UND MOSAIKE / DECORS ET MOSAÏQUE

pag. 344

pag. 346

pag. 348

ARDESIA BORDEAUX

PIETRE NATURALI HIGH-TECH

PROVENIENZA BRASILE

ORIGIN BRAZIL / HERKUNFT BRASIL /
PROVENANCE BRÉSIL

REPERIBILITÀ BUONA

AVAILABILITY GOOD /
VERFÜGBARKEIT REICHLICH /
DISPONIBILITÉ BONNE

RETTIFICATO MONOCALIBRO

RECTIFIED SINGLE-CALIBRE / REKTIFIZIERT EINKALIBRIG /
RECTIFIÉ MONOCALIBRE

SPESSORE

THICKNESS / DICKE / ÉPAISSEUR

10mm

FORMATI

SIZES / FORMATE / FORMATS

60 x 60 cm
24" x 24"

60 x 30 cm
24" x 12"

60 x 15 cm
24" x 6"

60 x 10 cm
24" x 4"

30 x 30 cm
12" x 12"

SUPERFICI

SURFACES
OBERFLÄCHEN
SURFACES

COEFFICIENTE DI ATTRITO

FRICTION COEFFICIENT
REIBUNGSKOEFFIZIENT
COEFFICIENT DE FROTTEMENT

DI FABBRICA

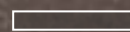
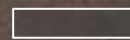
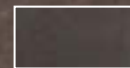

STRUTTURATO / STRUCTURED / STRUKTURIERT / STRUCTURÉ

HIGH HONED

ST (R11) A+B

pag. 344

pag. 346

pag. 348

FORMATI / SIZES / FORMATE / FORMATS

PEZZI SPECIALI / TRIMS / FORMTEILE / PIÈCES SPÉCIALES

DECORI E MOSAICI / DECORS AND MOSAICS / DEKORE UND MOSAIKE / DECORS ET MOSAÏQUE

PIETRA DI MERANO

PROVENIENZA ITALIA
ORIGIN ITALY / HERKUNFT ITALIEN /
PROVENANCE ITALIE

REPERIBILITÀ LIMITATA
AVAILABILITY SCARCE /
VERFÜGBARKEIT BEGRENZT /
DISPONIBILITÉ LIMITÉE

RETTIFICATO MONOCALIBRO
RECTIFIED SINGLE-CALIBRE / REKTIFIZIERT EINKALIBRIG /
RECTIFIÉ MONOCALIBRE

SPESSORE
THICKNESS / DICKE / ÉPAISSEUR

10mm

FORMATI
SIZES / FORMATE / FORMATS

60 x 60 cm
24" x 24"

60 x 30 cm
24" x 12"

60 x 15 cm
24" x 6"

60 x 10 cm
24" x 4"

SUPERFICI
SURFACES
OBERFLÄCHEN
SURFACES

COEFFICIENTE DI ATTRITO
FRICTION COEFFICIENT
REIBUNGSKOEFFIZIENT
COEFFICIENT DE FROTTEMENT

FORMATI / SIZES / FORMATE / FORMATS
PEZZI SPECIALI / TRIMS / FORMTEILE / PIÈCES SPÉCIALES

DECORI E MOSAICI / DECORS AND MOSAICS / DEKORE UND MOSAIKE / DECORS ET MOSAÏQUE

PIETRE NATURALI HIGH-TECH

DI FABBRICA



STRUTTURATO / STRUCTURED / STRUKTURIERT / STRUCTURÉ

SATINATO / SATIN-FINISH / SATINIERT / SATINÉ

ST (R11) A+B+C

SA (R10) A+B+C

pag. 344

pag. 346

pag. 348

PIETRA DELL'ESTEREL

PROVENIENZA FRANCIA

ORIGIN FRANCE / HERKUNFT FRANKREICH /
PROVENANCE FRANCE

REPERIBILITÀ MODESTA

AVAILABILITY SCARCE /
VERFÜGBARKEIT BESCHIEDEN /
DISPONIBILITÉ MODESTE

RETTIFICATO MONOCALIBRO

RECTIFIED SINGLE-CALIBRE / REKTIFIZIERT EINKALIBRIG /
RECTIFIÉ MONOCALIBRE

SPESSORE

THICKNESS / DICKE / ÉPAISSEUR

10mm

FORMATI

SIZES / FORMATE / FORMATS

60 x 60 cm
24"x 24"

60 x 30 cm
24"x 12"

60 x 15 cm
24"x 6"

60 x 10 cm
24"x 4"

SUPERFICI

SURFACES
OBERFLÄCHEN
SURFACES

COEFFICIENTE DI ATTRITO

FRICTION COEFFICIENT
REIBUNGSKOEFFIZIENT
COEFFICIENT DE FROTTEMENT

FORMATI / SIZES / FORMATE / FORMATS

PEZZI SPECIALI / TRIMS / FORMTEILE / PIÈCES SPÉCIALES

DECORI E MOSAICI / DECORS AND MOSAICS / DEKORE UND MOSAIKE / DECORS ET MOSAÏQUE

PIETRE NATURALI HIGH-TECH

DI FABBRICA



STRUTTURATO / STRUCTURED / STRUKTURIERT / STRUCTURÉ

ST (R11) A

pag. 344

pag. 346

pag. 348



stone innovation

Il nome Pietra d'Avola e la finitura Bamboo sono repliche dell'originale in pietra naturale studiate e realizzate dalla Salvatori marmi e riprodotte su gentile concessione.

www.salvatori.it

The name Pietra d'Avola and finishing Bamboo are replicas of the original natural stone designed and manufactured by Salvatori marbles and reproduced by kind concession.

www.salvatori.it

PIETRA D'AVOLA

PROVENIENZA ITALIA

ORIGIN ITALY / HERKUNFT ITALIEN /
PROVENANCE ITALIE

REPERIBILITÀ BUONA

AVAILABILITY GOOD /
VERFÜGBARKEIT REICHLICH /
DISPONIBILITÉ BONNE

RETTIFICATO MONOCALIBRO

RECTIFIED SINGLE-CALIBRE / REKTIFIZIERT EINKALIBRIG /
RECTIFIÉ MONOCALIBRE

SPESSORE

THICKNESS / DICKE / ÉPAISSEUR

▼
10mm
▲

FORMATI

SIZES / FORMATE / FORMATS

120 x 60 cm
48" x 24"



120 x 30 cm
48" x 12"



60 x 60 cm
24" x 24"



60 x 30 cm
24" x 12"



SUPERFICI

SURFACES
OBERFLÄCHEN
SURFACES

NATURALE / NATURAL / NATURBELASSEN / NATUREL

BAMBOO

COEFFICIENTE DI ATTRITO

FRICTION COEFFICIENT
REIBUNGSKOEFFIZIENT
COEFFICIENT DE FROTTEMENT

N **(R9)** A

BA **(R12)** A+B+C

pag. 344

pag. 346

pag. 348

FORMATI / SIZES / FORMATE / FORMATS

PEZZI SPECIALI / TRIMS / FORMTEILE / PIÈCES SPÉCIALES

DECORI E MOSAICI / DECORS AND MOSAICS / DEKORE UND MOSAIKE / DECORS ET MOSAÏQUE

PIETRE NATURALI HIGH-TECH

DI FABBRICA

PIETRA DI RAGUSA

PROVENIENZA ITALIA
ORIGIN ITALY / HERKUNFT ITALIEN /
PROVENANCE ITALIE

REPERIBILITÀ LIMITATA
AVAILABILITY SCARCE /
VERFÜGBARKEIT BEGRENZT /
DISPONIBILITÉ LIMITÉE

RETTIFICATO MONOCALIBRO
RECTIFIED SINGLE-CALIBRE / REKTIFIZIERT EINKALIBRIG /
RECTIFIÉ MONOCALIBRE

SPESSORE
THICKNESS / DICKE / ÉPAISSEUR

▼
10mm
▲

◀
cm²
▶

FORMATI
SIZES / FORMATE / FORMATS

90 x 45 cm
36" x 17^{3/4}"

90 x 9 cm
36" x 3^{3/5}"

60 x 60 cm
24" x 24"

60 x 30 cm
24" x 12"

60 x 15 cm
24" x 6"

60 x 10 cm
24" x 4"

30 x 30 cm
12" x 12"

30 x 15 cm
12" x 6"

15 x 15 cm
6" x 6"

SUPERFICI
SURFACES
OBERFLÄCHEN
SURFACES

COEFFICIENTE DI ATTRITO
FRICTION COEFFICIENT
REIBUNGSKOEFFIZIENT
COEFFICIENT DE FROTTEMENT

FORMATI / SIZES / FORMATE / FORMATS

PEZZI SPECIALI / TRIMS / FORMTEILE / PIÈCES SPÉCIALES

DECORI E MOSAICI / DECORS AND MOSAICS / DEKORE UND MOSAIKE / DECORS ET MOSAÏQUE

PIETRE NATURALI HIGH-TECH

DI FABBRICA

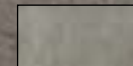

STRUTTURATO / STRUCTURED / STRUKTURIERT / STRUCTURÉ

ST (R11) A+B

pag. 344

pag. 346

pag. 348



PIETRA DI LUSERNA

PIETRE NATURALI HIGH-TECH

PROVENIENZA ITALIA

ORIGIN ITALY / HERKUNFT ITALIEN /
PROVENANCE ITALIE

REPERIBILITÀ BUONA

AVAILABILITY GOOD /
VERFÜGBARKEIT REICHLICH /
DISPONIBILITÉ BONNE

RETTIFICATO MONOCALIBRO

RECTIFIED SINGLE-CALIBRE / REKTIFIZIERT EINKALIBRIG /
RECTIFIÉ MONOCALIBRE

SPESSORE

THICKNESS / DICKE / ÉPAISSEUR

10mm

DI FABBRICA

FORMATI

SIZES / FORMATE / FORMATS

60 x 60 cm
24" x 24"



60 x 30 cm
24" x 12"



60 x 15 cm
24" x 6"



60 x 10 cm
24" x 4"



30 x 30 cm
12" x 12"



30 x 15 cm
12" x 6"



15 x 15 cm
6" x 6"



SUPERFICI

SURFACES
OBERFLÄCHEN
SURFACES

STRUTTURATO / STRUCTURED / STRUKTURIERT / STRUCTURÉ

SATINATO / SATIN-FINISH / SATINIERT / SATINÉ

COEFFICIENTE DI ATTRITO

FRICTION COEFFICIENT
REIBUNGSKOEFFIZIENT
COEFFICIENT DE FROTTEMENT

ST (R11) A+B

SA (R9)

FORMATI / SIZES / FORMATE / FORMATS

PEZZI SPECIALI / TRIMS / FORMTEILE / PIÈCES SPÉCIALES

DECORI E MOSAICI / DECORS AND MOSAICS / DEKORE UND MOSAIKE / DECORS ET MOSAÏQUE

pag. 344

pag. 346

pag. 348

SILVER GREY

PROVENIENZA INDIA
ORIGIN INDIA / HERKUNFT INDIEN /
PROVENANCE INDE

REPERIBILITÀ MODESTA
AVAILABILITY SCARCE /
VERFÜGBARKEIT BESCHIEDEN /
DISPONIBILITÉ MODESTE

RETTIFICATO MONOCALIBRO
RECTIFIED SINGLE-CALIBRE / REKTIFIZIERT EINKALIBRIG /
RECTIFIÉ MONOCALIBRE

SPESSORE
THICKNESS / DICKE / ÉPAISSEUR

10mm



FORMATI
SIZES / FORMATE / FORMATS

120 x 60 cm
48" x 24"

60 x 60 cm
24" x 24"

60 x 30 cm
24" x 12"

60 x 15 cm
24" x 6"

60 x 10 cm
24" x 4"

SUPERFICI
SURFACES
OBERFLÄCHEN
SURFACES

COEFFICIENTE DI ATTRITO
FRICTION COEFFICIENT
REIBUNGSKOEFFIZIENT
COEFFICIENT DE FROTTEMENT

FORMATI / SIZES / FORMATE / FORMATS
PEZZI SPECIALI / TRIMS / FORMTEILE / PIÈCES SPÉCIALES
DECORI E MOSAICI / DECORS AND MOSAICS / DEKORE UND MOSAIKE / DECORS ET MOSAÏQUE

GREENSTONE

DI FABBRICA

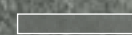
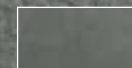

STRUTTURATO / STRUCTURED / STRUKTURIERT / STRUCTURÉ
SEMILUCIDATO / SEMI-POLISHED / SEMI-MATT / SEMI-LUSTRÉ

ST **R11** A+B+C

SL **R10** A

pag. 344
pag. 346
pag. 348

BASALTO GRIGIO

PIETRE NATURALI HIGH-TECH

PROVENIENZA ITALIA

ORIGIN ITALY / HERKUNFT ITALIEN /
PROVENANCE ITALIE

REPERIBILITÀ MODESTA

AVAILABILITY SCARCE /
VERFÜGBARKEIT BESCHIEDEN /
DISPONIBILITÉ MODESTE

RETTIFICATO MONOCALIBRO

RECTIFIED SINGLE-CALIBRE / REKTIFIZIERT EINKALIBRIG /
RECTIFIÉ MONOCALIBRE

SPESSORE

THICKNESS / DICKE / ÉPAISSEUR

10mm

cm

FORMATI

SIZES / FORMATE / FORMATS

120 x 60 cm
48" x 24"



60 x 60 cm
24" x 24"



60 x 30 cm
24" x 12"

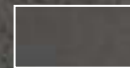

60 x 15 cm
24" x 6"

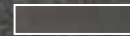

60 x 10 cm
24" x 4"

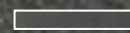

SUPERFICI

SURFACES
OBERFLÄCHEN
SURFACES

STRUTTURATO / STRUCTURED / STRUKTURIERT / STRUCTURÉ

SATINATO / SATIN-FINISH / SATINIERT / SATINÉ

COEFFICIENTE DI ATTRITO

FRICTION COEFFICIENT
REIBUNGSKOEFFIZIENT
COEFFICIENT DE FROTTEMENT

ST (R11) A+B+C

SA (R10) A+B+C

FORMATI / SIZES / FORMATE / FORMATS

PEZZI SPECIALI / TRIMS / FORMTEILE / PIÈCES SPÉCIALES

DECORI E MOSAICI / DECORS AND MOSAICS / DEKORE UND MOSAIKE / DECORS ET MOSAÏQUE

pag. 344

pag. 346

pag. 348

ARDESIA ANTRACITE

PROVENIENZA INDIA
ORIGIN INDIA / HERKUNFT INDIEN /
PROVENANCE INDE

REPERIBILITÀ MODESTA
AVAILABILITY SCARCE /
VERFÜGBARKEIT BESCHEIDEN /
DISPONIBILITÉ MODESTE

RETTIFICATO MONOCALIBRO
RECTIFIED SINGLE-CALIBRE / REKTIFIZIERT EINKALIBRIG /
RECTIFIÉ MONOCALIBRE

SPESSORE
THICKNESS / DICKE / ÉPAISSEUR

▼
10mm
▲



FORMATI
SIZES / FORMATE / FORMATS

120 x 60 cm
48" x 24"

60 x 60 cm
24" x 24"

60 x 30 cm
24" x 12"

60 x 15 cm
24" x 6"

60 x 10 cm
24" x 4"

SUPERFICI
SURFACES
OBERFLÄCHEN
SURFACES

COEFFICIENTE DI ATTRITO
FRICTION COEFFICIENT
REIBUNGSKOEFFIZIENT
COEFFICIENT DE FROTTEMENT

FORMATI / SIZES / FORMATE / FORMATS
PEZZI SPECIALI / TRIMS / FORMTEILE / PIÈCES SPÉCIALES

DECORI E MOSAICI / DECORS AND MOSAICS / DEKORE UND MOSAIKE / DECORS ET MOSAÏQUE

GREENSTONE

DI FABBRICA

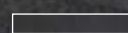
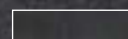
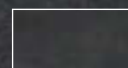
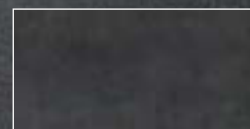

STRUTTURATO / STRUCTURED / STRUKTURIERT / STRUCTURÉ
SEMILUCIDATO / SEMI-POLISHED / SEMI-MATT / SEMI-LUSTRÉ

ST **(R11)** A+B+C

SL **(R10)** A

pag. 344
pag. 346
pag. 348

BLACK ARDESIA

PIETRE NATURALI HIGH-TECH

PROVENIENZA SPAGNA

ORIGIN SPAIN / HERKUNFT SPANIEN /
PROVENANCE ESPAGNE

REPERIBILITÀ BUONA

AVAILABILITY GOOD /
VERFÜGBARKEIT REICHLICH /
DISPONIBILITÉ BONNE

RETTIFICATO MONOCALIBRO

RECTIFIED SINGLE-CALIBRE / REKTIFIZIERT EINKALIBRIG /
RECTIFIÉ MONOCALIBRE

SPESSORE

THICKNESS / DICKE / ÉPAISSEUR

10mm

FORMATI

SIZES / FORMATE / FORMATS

120 x 60 cm
48" x 24"

90 x 90 cm
36" x 36"

90 x 45 cm
36" x 17^{3/4}"

90 x 9 cm
36" x 3^{3/5}"

60 x 60 cm
24" x 24"

60 x 30 cm
24" x 12"

60 x 15 cm
24" x 6"

60 x 10 cm
24" x 4"

30 x 30 cm
12" x 12"

30 x 15 cm
12" x 6"

15 x 15 cm
6" x 6"

SUPERFICI

SURFACES
OBERFLÄCHEN
SURFACES

COEFFICIENTE DI ATTRITO

FRICTION COEFFICIENT
REIBUNGSKOEFFIZIENT
COEFFICIENT DE FROTTEMENT

FORMATI / SIZES / FORMATE / FORMATS

PEZZI SPECIALI / TRIMS / FORMTEILE / PIÈCES SPÉCIALES

DECORI E MOSAICI / DECORS AND MOSAICS / DEKORE UND MOSAIKE / DECORS ET MOSAÏQUE

DI FABBRICA

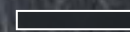
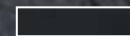
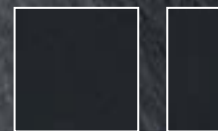
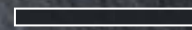
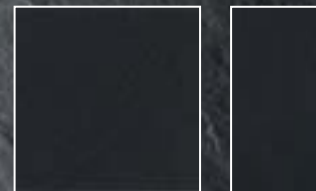
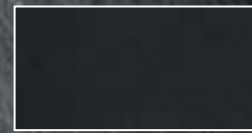

STRUTTURATO / STRUCTURED / STRUKTURIERT / STRUCTURÉ

SATINATO / SATIN-FINISH / SATINIERT / SATINÉ

HIGH HONED

ST (R10) A+B

SA (R10)

pag. 344

pag. 346

pag. 348

CADAPPA BLACK

PROVENIENZA INDIA

ORIGIN INDIA / HERKUNFT INDIEN /
PROVENANCE INDE

REPERIBILITÀ MODESTA

AVAILABILITY SCARCE /
VERFÜGBARKEIT BESCHEIDEN /
DISPONIBILITÉ MODESTE

RETTIFICATO MONOCALIBRO

RECTIFIED SINGLE-CALIBRE / REKTIFIZIERT EINKALIBRIG /
RECTIFIÉ MONOCALIBRE

SPESSORE

THICKNESS / DICKE / ÉPAISSEUR

10mm



FORMATI

SIZES / FORMATE / FORMATS

120 x 60 cm
48" x 24"

60 x 60 cm
24" x 24"

60 x 30 cm
24" x 12"

60 x 15 cm
24" x 6"

60 x 10 cm
24" x 4"

SUPERFICI

SURFACES
OBERFLÄCHEN
SURFACES

COEFFICIENTE DI ATTRITO

FRICTION COEFFICIENT
REIBUNGSKOEFFIZIENT
COEFFICIENT DE FROTTEMENT

FORMATI / SIZES / FORMATE / FORMATS

PEZZI SPECIALI / TRIMS / FORMTEILE / PIÈCES SPÉCIALES

DECORI E MOSAICI / DECORS AND MOSAICS / DEKORE UND MOSAIKE / DECORS ET MOSAÏQUE

GREENSTONE

DI FABBRICA

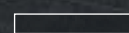
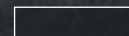
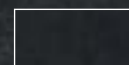
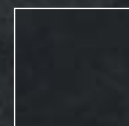
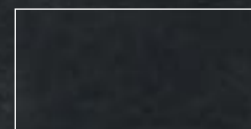

STRUTTURATO / STRUCTURED / STRUKTURIERT / STRUCTURÉ

SEMILUCIDATO / SEMI-POLISHED / SEMI-MATT / SEMI-LUSTRÉ

ST (R11) A+B

SL (R10) A

pag. 344

pag. 346

pag. 348

GESSO	194
SABBIA	196
CENERE	198
FANGO	200
LAVA	202
GHIACCIO	204
DIORITE	206
PELTRO	208
LIGNITE	210

MATERIE HIGH-TECH

150X75

GESSO

MATERIE HIGH_TECH

RETTIFICATO MONOCALIBRO
RECTIFIED SINGLE-CALIBRE / REKTIFIZIERT EINKALIBRIG /
RECTIFIÉ MONOCALIBRE

FORMATI
SIZES / FORMATE / FORMATS

SPESSORE
THICKNESS / DICKE / ÉPAISSEUR

▼
8 mm
▲

150 x 75 cm
60" x 30"

75 x 75 cm
30" x 30"

SUPERFICI
SURFACES
OBERFLÄCHEN
SURFACES

COEFFICIENTE DI ATTRITO
FRICTION COEFFICIENT
REIBUNGSKOEFFIZIENT
COEFFICIENT DE FROTTEMENT

SPESSORE
THICKNESS / DICKE / ÉPAISSEUR

▼
10 mm
▲

120 x 60 cm
48" x 24"

60 x 60 cm
24" x 24"

60 x 30 cm
24" x 12"

SUPERFICI
SURFACES
OBERFLÄCHEN
SURFACES

COEFFICIENTE DI ATTRITO
FRICTION COEFFICIENT
REIBUNGSKOEFFIZIENT
COEFFICIENT DE FROTTEMENT

FORMATI / SIZES / FORMATE / FORMATS
PEZZI SPECIALI / TRIMS / FORMTEILE / PIÈCES SPÉCIALES



SOFT

SO (R9)

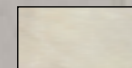

SOFT

NATURALE / NATURAL / NATURBELASSEN / NATUREL

SO (R9)

N (R10) A+B

pag. 343
pag. 343

150X75

SABBIA

MATERIE HIGH_TECH

RETTIFICATO MONOCALIBRO
RECTIFIED SINGLE-CALIBRE / REKTIFIZIERT EINKALIBRIG /
RECTIFIÉ MONOCALIBRE

FORMATI
SIZES / FORMATE / FORMATS

SPESSORE
THICKNESS / DICKE / ÉPAISSEUR

▼
8 mm
▲

150 x 75 cm
60" x 30"



75 x 75 cm
30" x 30"



SUPERFICI
SURFACES
OBERFLÄCHEN
SURFACES

SOFT

COEFFICIENTE DI ATTRITO
FRICTION COEFFICIENT
REIBUNGSKOEFFIZIENT
COEFFICIENT DE FROTTEMENT

SO (R9)

SPESSORE
THICKNESS / DICKE / ÉPAISSEUR

▼
10 mm
▲

120 x 60 cm
48" x 24"



60 x 60 cm
24" x 24"



60 x 30 cm
24" x 12"



SUPERFICI
SURFACES
OBERFLÄCHEN
SURFACES

SOFT

NATURALE / NATURAL / NATURBELASSEN / NATUREL

COEFFICIENTE DI ATTRITO
FRICTION COEFFICIENT
REIBUNGSKOEFFIZIENT
COEFFICIENT DE FROTTEMENT

SO (R9)

N (R10) A+B

150X75

CENERE

MATERIE HIGH_TECH

RETTIFICATO MONOCALIBRO
RECTIFIED SINGLE-CALIBRE / REKTIFIZIERT EINKALIBRIG /
RECTIFIÉ MONOCALIBRE

FORMATI
SIZES / FORMATE / FORMATS

SPESSORE
THICKNESS / DICKE / ÉPAISSEUR

▼
8 mm
▲

150 x 75 cm
60" x 30"



75 x 75 cm
30" x 30"



SUPERFICI
SURFACES
OBERFLÄCHEN
SURFACES

SOFT

COEFFICIENTE DI ATTRITO
FRICTION COEFFICIENT
REIBUNGSKOEFFIZIENT
COEFFICIENT DE FROTTEMENT

SO (R9)

SPESSORE
THICKNESS / DICKE / ÉPAISSEUR

▼
10 mm
▲
cm2

120 x 60 cm
48" x 24"



60 x 60 cm
24" x 24"



60 x 30 cm
24" x 12"



SUPERFICI
SURFACES
OBERFLÄCHEN
SURFACES

SOFT

NATURALE / NATURAL / NATURBELASSEN / NATUREL

cm2

COEFFICIENTE DI ATTRITO
FRICTION COEFFICIENT
REIBUNGSKOEFFIZIENT
COEFFICIENT DE FROTTEMENT

SO (R9)

N (R10) A+B

cm2 (R11) A+B

FORMATI / SIZES / FORMATE / FORMATS
PEZZI SPECIALI / TRIMS / FORMTEILE / PIÈCES SPÉCIALES

pag. 343
pag. 343

150X75

FANGO

MATERIE HIGH_TECH

RETTIFICATO MONOCALIBRO
RECTIFIED SINGLE-CALIBRE / REKTIFIZIERT EINKALIBRIG /
RECTIFIÉ MONOCALIBRE

FORMATI
SIZES / FORMATE / FORMATS

SPESSORE
THICKNESS / DICKE / ÉPAISSEUR

▼
8 mm
▲

150 x 75 cm
60" x 30"



75 x 75 cm
30" x 30"



SUPERFICI
SURFACES
OBERFLÄCHEN
SURFACES

SOFT

COEFFICIENTE DI ATTRITO
FRICTION COEFFICIENT
REIBUNGSKOEFFIZIENT
COEFFICIENT DE FROTTEMENT

SO (R9)

SPESSORE
THICKNESS / DICKE / ÉPAISSEUR

▼
10 mm
▲

cm²

120 x 60 cm
48" x 24"

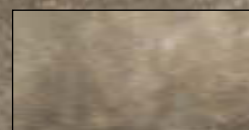

60 x 60 cm
24" x 24"



60 x 30 cm
24" x 12"



SUPERFICI
SURFACES
OBERFLÄCHEN
SURFACES

SOFT

NATURALE / NATURAL / NATURBELASSEN / NATUREL

cm²

COEFFICIENTE DI ATTRITO
FRICTION COEFFICIENT
REIBUNGSKOEFFIZIENT
COEFFICIENT DE FROTTEMENT

SO (R9)

N (R10) A+B

cm² (R11) A+B

RETTIFICATO MONOCALIBRORECTIFIED SINGLE-CALIBRE / REKTIFIZIERT EINKALIBRIG /
RECTIFIÉ MONOCALIBRE**FORMATI**

SIZES / FORMATE / FORMATS

SPESSORE

THICKNESS / DICKE / ÉPAISSEUR

8 mm

150 x 75 cm
60" x 30"75 x 75 cm
30" x 30"**SUPERFICI**SURFACES
OBERFLÄCHEN
SURFACES**COEFFICIENTE DI ATTRITO**FRICTION COEFFICIENT
REIBUNGSKOEFFIZIENT
COEFFICIENT DE FROTTEMENT**SPESSORE**

THICKNESS / DICKE / ÉPAISSEUR

10 mm

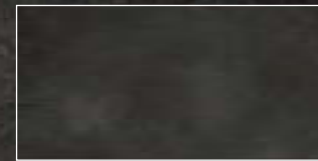
120 x 60 cm
48" x 24"60 x 60 cm
24" x 24"60 x 30 cm
24" x 12"**SUPERFICI**SURFACES
OBERFLÄCHEN
SURFACES**COEFFICIENTE DI ATTRITO**FRICTION COEFFICIENT
REIBUNGSKOEFFIZIENT
COEFFICIENT DE FROTTEMENT

SOFT

SO (R9)

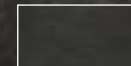

SOFT

NATURALE / NATURAL / NATURBELASSEN / NATUREL

SO (R9)

N (R10) A+B

GHIACCIO

MATERIE HIGH_TECH

RETTIFICATO MONOCALIBRO
RECTIFIED SINGLE-CALIBRE / REKTIFIZIERT EINKALIBRIG /
RECTIFIÉ MONOCALIBRE

SPESSORE
THICKNESS / DICKE / ÉPAISSEUR

▼
10 mm
▲

FORMATI
SIZES / FORMATE / FORMATS

120 x 60 cm
48" x 24"

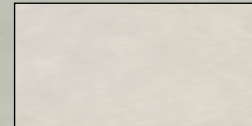

60 x 60 cm
24" x 24"

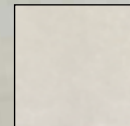

60 x 30 cm
24" x 12"

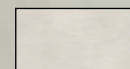

SUPERFICI
SURFACES
OBERFLÄCHEN
SURFACES

SOFT

NATURALE / NATURAL / NATURBELASSEN / NATUREL

COEFFICIENTE DI ATTRITO
FRICTION COEFFICIENT
REIBUNGSKOEFFIZIENT
COEFFICIENT DE FROTTEMENT

SO (R9)

N (R10) A+B

DIORITE

MATERIE HIGH_TECH

RETTIFICATO MONOCALIBRO
RECTIFIED SINGLE-CALIBRE / REKTIFIZIERT EINKALIBRIG /
RECTIFIÉ MONOCALIBRE

SPESSORE
THICKNESS / DICKE / ÉPAISSEUR

10 mm
cm2

FORMATI
SIZES / FORMATE / FORMATS

120 x 60 cm
48" x 24"

60 x 60 cm
24" x 24"

60 x 30 cm
24" x 12"

SUPERFICI
SURFACES
OBERFLÄCHEN
SURFACES

COEFFICIENTE DI ATTRITO
FRICTION COEFFICIENT
REIBUNGSKOEFFIZIENT
COEFFICIENT DE FROTTEMENT

FORMATI / SIZES / FORMATE / FORMATS
PEZZI SPECIALI / TRIMS / FORMTEILE / PIÈCES SPÉCIALES

SOFT

NATURALE / NATURAL / NATURBELASSEN / NATUREL

cm2

SO (R9)

N (R10) A+B

cm2 (R11) A+B

pag. 343
pag. 343

PELTRO

MATERIE HIGH_TECH

RETTIFICATO MONOCALIBRO

RECTIFIED SINGLE-CALIBRE / REKTIFIZIERT EINKALIBRIG /
RECTIFIÉ MONOCALIBRE

SPESSORE

THICKNESS / DICKE / ÉPAISSEUR

10 mm
cm²

FORMATI

SIZES / FORMATE / FORMATS

120 x 60 cm
48" x 24"

60 x 60 cm
24" x 24"

60 x 30 cm
24" x 12"

SUPERFICI

SURFACES
OBERFLÄCHEN
SURFACES

COEFFICIENTE DI ATTRITO

FRICTION COEFFICIENT
REIBUNGSKOEFFIZIENT
COEFFICIENT DE FROTTEMENT

SOFT

NATURALE / NATURAL / NATURBELASSEN / NATUREL

cm²

SO (R9)

N (R10) A+B

cm² (R11) A+B

LIGNITE

MATERIE HIGH_TECH

RETTIFICATO MONOCALIBRO
RECTIFIED SINGLE-CALIBRE / REKTIFIZIERT EINKALIBRIG /
RECTIFIÉ MONOCALIBRE

SPESORE
THICKNESS / DICKE / ÉPAISSEUR

10 mm

FORMATI
SIZES / FORMATE / FORMATS

120 x 60 cm
48" x 24"

60 x 60 cm
24" x 24"

60 x 30 cm
24" x 12"

SUPERFICI
SURFACES
OBERFLÄCHEN
SURFACES

COEFFICIENTE DI ATTRITO
FRICTION COEFFICIENT
REIBUNGSKOEFFIZIENT
COEFFICIENT DE FROTTEMENT

FORMATI / SIZES / FORMATE / FORMATS
PEZZI SPECIALI / TRIMS / FORMTEILE / PIÈCES SPÉCIALES

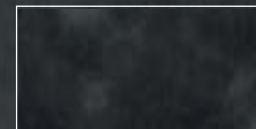

SOFT

NATURALE / NATURAL / NATURBELASSEN / NATUREL

SO (R9)

N (R10) A+B

pag. 343
pag. 343

ACTIVE™

CLEAN AIR & ANTIBACTERIAL CERAMIC

BE ACTIVE

BE a TREE!

DESCRIZIONE Active Clean Air & Antibacterial Ceramic™ è una nuova finitura ottenuta attraverso una metodologia basata su un trattamento innovativo al biossido di titanio in forma micrometrica, che agisce da fotocatalizzatore, effettuato sulle lastre in gres porcellanato a temperatura elevata.

PROPRIETÀ L'applicazione di Active Clean Air & Antibacterial Ceramic™ concretizza le tre qualità del materiale, attivando tre azioni molto importanti che sono: antinquinante, antibatterica, autopulente (solo per pareti esterne).

UTILIZZO Le eccellenti qualità fisico chimiche di Active Clean Air & Antibacterial Ceramic™ lo rendono ideale per i seguenti impieghi: rivestimenti esterni di edifici, rivestimenti interni, rivestimenti nel settore: ospedaliero e sanitario, scolastico, wellness, ambiti in cui l'igiene è requisito indispensabile.

VANTAGGI In presenza di luce e aria si attiva un forte processo ossidativo che porta alla decomposizione di determinate sostanze organiche ed inorganiche quando queste vengano a contatto con la superficie di Active Clean Air & Antibacterial Ceramic™. I vantaggi che si possono trarre dall'utilizzo di Active sono: mantenimento e conservazione delle caratteristiche estetiche e, al contempo, la possibilità di avere superfici che repellono lo sporco, abbattimento di diversi inquinanti, purificazione dell'aria, eliminazione di batteri.

DESCRIPTION Active Clean Air & Antibacterial Ceramic™ is a new finish obtained through a production methodology based on an innovative micrometric titanium dioxide process, which acts as a photocatalyst, carried on porcelain slabs at high temperature.

PROPERTIES Applying Active Clean Air & Antibacterial Ceramic™ brings out the three qualities of the material, activating three very important actions that are: anti-pollution, antibacterial, self-cleaning (only for external walls).

USE The excellent physical-chemical characteristics of Active Clean Air & Antibacterial Ceramic™ make it ideal for the following applications: exterior cladding of buildings, interior, walls in following areas: Hospitals and health centres, Schools, Wellness centres, Environments where hygiene is an essential requirement.

ADVANTAGES In presence of light and air, a strong oxidation is activated by Active Clean Air & Antibacterial Ceramic™, that leads to the decomposition of particular organic and inorganic substances, when they come into contact with the surface of Active. The benefits achieved with the use of Active are: maintenance and preservation of aesthetic characteristics and, meanwhile, the possibility to have surfaces repelling dirt, abatement of different pollutants, air purification, elimination of bacteria.



TITANIUM DIOXIDE



HOW PHOTOCATALYSIS
FIGHTS POLLUTION



100%

BACTERICIDAL EFFICACY

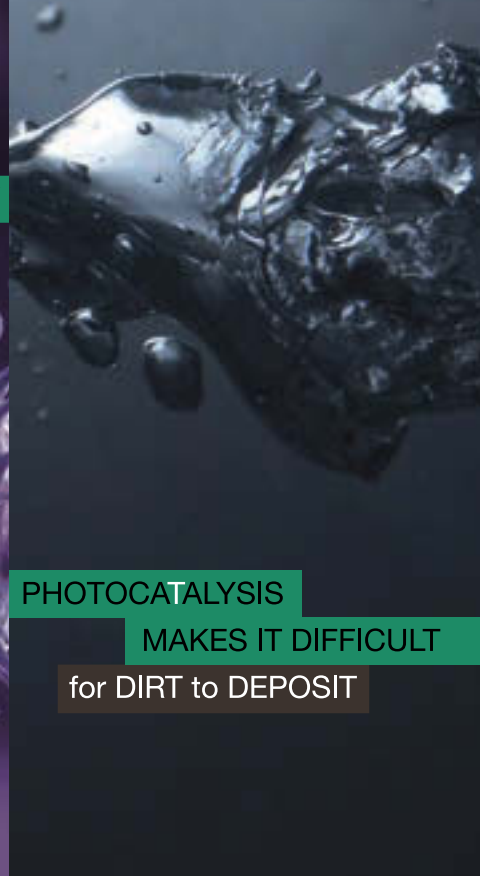

PHOTOCATALYSIS
MAKES IT DIFFICULT
for DIRT to DEPOSIT

BESCHREIBUNG Active Clean Air & Antibacterial Ceramic™ ist eine neue Ausführung, die auf einer innovativen Behandlung mit als Fotokatalysator wirkendem Titanbioxyd in mikrometrischer Form basiert. Die Behandlung der Feinsteinzeugplatten erfolgt bei hoher Temperatur.

EIGENSCHAFTEN Die Anwendung von Active Clean Air & Antibacterial Ceramic™ konkretisiert die drei Qualitäten des Materials durch: umweltschützende Wirkung, antibakterielle Wirkung, selbstreinigende Wirkung (nur für Aussenfassaden).

VERWENDUNG Durch die vortrefflichen physikalisch-chemischen Eigenschaften von Active Clean Air & Antibacterial Ceramic™ eignet sich dieses Produkt vortrefflich für den Einsatz in den folgenden Bereichen: Außenverkleidungen von Gebäuden, Innenverkleidungen, Verkleidungen auf folgenden Gebieten: Spitäler/ Krankenhäuser und Sanitär, Schulen, Wellness, Umgebungen, in denen Hygiene absolut erforderlich ist.

VORTEILE Unter der Einwirkung von Licht tritt ein intensiver Oxydationsprozess ein, der zur Zersetzung gewisser organischer und nicht organischer Stoffe führt, wenn diese mit der Oberfläche des Active Clean Air & Antibacterial Ceramic™ in Berührung kommen. Die Verwendung von Active bringt folgende Vorteile: Aufrechterhaltung unveränderter ästhetischer Eigenschaften und gleichzeitig die Möglichkeit, über schmutzabstossende Oberflächen zu verfügen, Vernichtung verschiedener Schadstoffe, Reinigung der Luft, Beseitigung der Bakterien.

DESCRIPTION Active Clean Air & Antibacterial Ceramic™ est une nouvelle finition. La technique de fabrication s'appuie sur un traitement révolutionnaire qui utilise le dioxyde de titane à l'échelle micro-métrique – le photocatalyseur – sur les dalles en grès cérame, à hautes températures.

PROPRIÉTÉS Active Clean Air & Antibacterial Ceramic™ apporte les trois qualités matérielles via trois actions très importantes: antipolluante, antibactérienne, autonettoyante (seulement pour murs extérieurs).

APPLICATION Grâce à ses extraordinaires qualités physicochimiques, Active Clean Air & Antibacterial Ceramic™ est recommandé pour les applications suivantes: revêtement des façades, revêtements intérieurs, revêtements dans le secteur: hospitalier et sanitaire, éducation nationale, wellness, lieux où l'hygiène est un critère indispensable.

AVANTAGES L'action combinée de la lumière et de l'air déclenche une oxydation intense qui entraîne la décomposition de certaines substances organiques et inorganiques, lorsqu'elles entrent en contact avec le surface Active Clean Air & Antibacterial Ceramic™. Les avantages d'Active sont: maintien et conservation des caractéristiques esthétiques et, en même temps, possibilité d'avoir des surfaces autonettoyantes, réduction de plusieurs polluants, purification de l'air, suppression des bactéries.

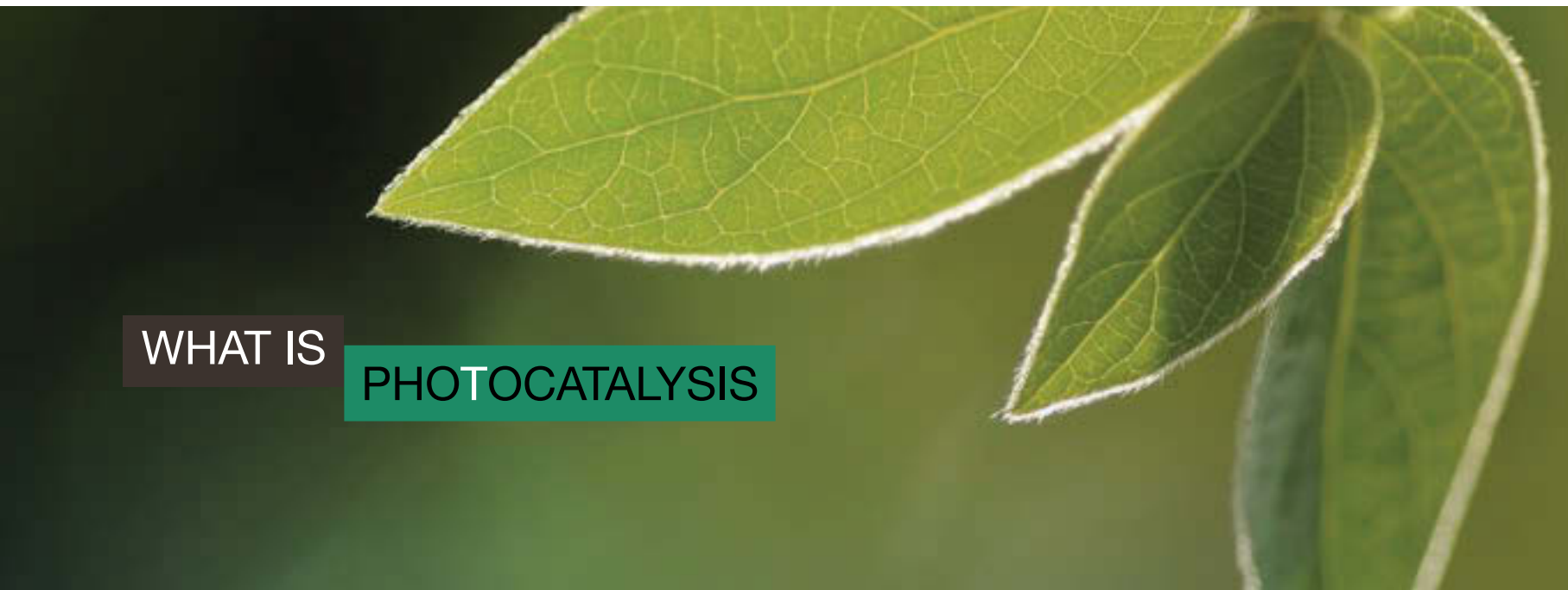

WHAT IS **PHOTOCATALYSIS**

150X75

PIETRA DI CALAIS

INNOVATIVE SLABS

ACTIVE™

RETTIFICATO MONOCALIBRO

RECTIFIED SINGLE-CALIBRE / REKTIFIZIERT EINKALIBRIG /
RECTIFIÉ MONOCALIBRE

SPESSORE

THICKNESS / DICKE / ÉPAISSEUR

10mm

FORMATI

SIZES / FORMATE / FORMATS

150 x 75 cm
60" x 30"



75 x 75 cm
30" x 30"

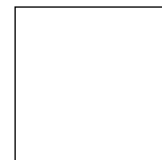

75 x 37,5 cm
30" x 15"



PIETRA DI BRUGGE

SUPERFICI / SURFACES / OBERFLÄCHEN / SURFACES

STRUTTURATO / STRUCTURED / STRUKTURIERT / STRUCTURÉ

FORMATI pag. 344

SIZES pag. 344 / FORMATE pag. 344 / FORMATS pag. 344

QUARZITE BIANCA

GREENSTONE

ACTIVE™

RETTIFICATO MONOCALIBRO

RECTIFIED SINGLE-CALIBRE / REKTIFIZIERT EINKALIBRIG /
RECTIFIÉ MONOCALIBRE

SPESSORE

THICKNESS / DICKE / ÉPAISSEUR

10mm

FORMATI

SIZES / FORMATE / FORMATS

120 x 60 cm
48" x 24"



60 x 60 cm
24" x 24"

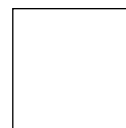

PIETRA SINTRA

SUPERFICI / SURFACES / OBERFLÄCHEN / SURFACES

STRUTTURATO / STRUCTURED / STRUKTURIERT / STRUCTURÉ

FORMATI pag. 344

SIZES pag. 344 / FORMATE pag. 344 / FORMATS pag. 344



ROVERE CORDA

120 x 30 cm

48" x 12"

120 x 20 cm

48" x 8"

120 x 15 cm

48" x 6"

LEGNI HIGH-TECH 

ACTIVE™

ROVERE GRIGIO

90 x 22,5 cm

36" x 9"

90 x 15 cm

36" x 6"

90 x 11 cm

36" x 4^{1/2}"

ROVERE BIANCO

90 x 22,5 cm

36" x 9"

90 x 15 cm

36" x 6"

90 x 11 cm

36" x 4^{1/2}"

RETTIFICATO MONOCALIBRO

RECTIFIED SINGLE-CALIBRE / REKTIFIZIERT EINKALIBRIG /
RECTIFIÉ MONOCALIBRE

SPESSORE

THICKNESS / DICKE / ÉPAISSEUR

▼
10mm
▲

SUPERFICI / SURFACES / OBERFLÄCHEN / SURFACES

ANTICATO / ANTIQUED / ANTIK / ANTIQUE

FORMATI pag. 350

SIZES pag. 350 / FORMATE pag. 350 / FORMATS pag. 350



ROVERE NATURALE

90 x 22,5 cm
36" x 9"

90 x 15 cm
36" x 6"

90 x 11 cm
36" x 4^{1/2}"

LEGNI HIGH-TECH 

ACTIVE™

ROVERE BIONDO

90 x 22,5 cm
36" x 9"

90 x 15 cm
36" x 6"

90 x 11 cm
36" x 4^{1/2}"

ROVERE MOKA

90 x 22,5 cm
36" x 9"

90 x 15 cm
36" x 6"

90 x 11 cm
36" x 4^{1/2}"

RETTIFICATO MONOCALIBRO

RECTIFIED SINGLE-CALIBRE / REKTIFIZIERT EINKALIBRIG /
RECTIFIÉ MONOCALIBRE

SPESSORE

THICKNESS / DICKE / ÉPAISSEUR

▼
10mm
▲

SUPERFICI / SURFACES / OBERFLÄCHEN / SURFACES

ANTICATO / ANTIQUED / ANTIK / ANTIQUE

FORMATI pag. 350

SIZES pag. 350 / FORMATE pag. 350 / FORMATS pag. 350



THE IDEAL SOLUTION FOR OUTDOOR PAVING

CM2 è la soluzione ideale per la pavimentazione in esterno, con destinazione d'uso sia pubblico che privato. Facile da posare, estremamente agevole per l'ispezione di eventuali impianti e riposizionabile rapidamente in caso di variazioni di posa o di modificazioni del sottofondo.

CM2 possiede spessore e massa atti a garantire le prestazioni di resistenza meccanica e longevità richieste dalle diverse situazioni di rivestimento outdoor:

- + PAVIMENTAZIONE SOPRAELEVATA SU SUPPORTI REGOLABILI E FISSI
- + PAVIMENTAZIONE CARRABILE CON POSA TRADIZIONALE SU MASSETTO
- + POSA A SECCO SU GHIAIA, SABBIA ED ERBA

CM2 ist die ideale Lösung für die Bodenabdeckung im Außenbereich, und zwar sowohl für die private wie auch die öffentliche Benützung. Einfach zu verlegen, kann dieses Produkt im Falle von Revisionen allfälliger Installationen leicht bewegt und bei Veränderungen der Abdeckung oder des Untergrunds rasch verlegt werden.

CM2 verfügt über eine Stärke und Masse, die eine für die Außenabdeckung geeignete mechanische Widerstandsfähigkeit und Langlebigkeit garantieren:

- + BODENBELÄGE, DIE AUF EINSTELLBAREN ODER FIXEN STÜTZEN VERLEGT WERDEN
- + BEFAHRBARE BODENBELÄGE, DIE AUF EINER TRADITIONELLEN ZEMENTUNTERLAGE ANGEBRACHT WERDEN
- + TROCKENVERLEGUNG AUF KIES, SAND ODER GRAS

CM2 is the ideal solution for outdoor paving, designed for both public and private use.

Easy to install, very easy to inspect any utilities, and easy to reposition in the event of changes to the installation or modifications to the substrate.

CM2 has dimensions and mass such as to guarantee the mechanical resistance and longevity demanded by the diverse requirements of outdoor paving:

- + RAISED PAVING ON ADJUSTABLE OR FIXED SUPPORTS
- + DRIVEWAY PAVING WITH TRADITIONAL INSTALLATION ON SCREED
- + DRY INSTALLATION ON GRAVEL, SAND OR GRASS

CM2 est la solution idéale pour les sols extérieurs, à usage public et privé. Facile à installer, extrêmement maniable pour l'inspection d'éventuelles installations, les dalles peuvent être repositionnées rapidement en cas de variations de pose ou de modifications du support.

La masse et l'épaisseur de CM2 peuvent assurer les prestations de résistance mécanique et de longévité que les différentes situations revêtement demandent:

- + SOL SURÉLEVÉ SUR SUPPORT RÉGLABLES ET FIXES
- + SOL CARROSSABLE AVEC UNE POSE TRADITIONNELLE SUR CHAPE DE CIMENT
- + POSE À SEC SUR GRAVIER, SABLE ET HERBE

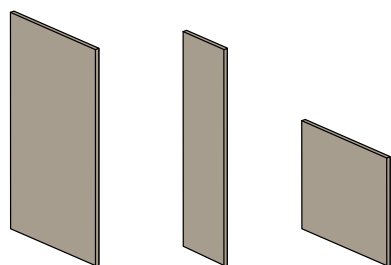

120 x 60
48" x 24"

120 x 30
48" x 12"

60 x 60
24" x 24"

FORMATI /
SIZES / FORMATE / FORMATS

GRADONE BECCO CM2
STEPTREAD WITH HALF BULLNOSE EDGE CM2 / STUFENPLATTE MIT ABGERUNDETER KANTE CM2 / NEZ DE MARCHE AVEC BORD ARRONDI CM2

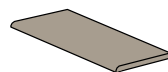

60 x 30
24" x 12"

GRADONE TORO CM2 /
STEPTREAD GRADONE TORO CM2 / STUFENPLATTE TORO CM2 / NEZ DE MARCHE ÉPAISSEUR CM2

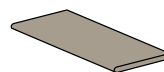

60 x 30
24" x 12"

GRIGLIA CM2
WATER GRATE / ABDECKPLATTE WASSERABLAUF / GRILLE

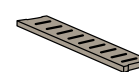

60 x 15
24" x 6"

PEZZI SPECIALI /
TRIMS / FORMTEILE / PIÈCES SPÉCIALES



APPLICAZIONI DEL CM2

APPLICATIONS OF CM2

ANWENDUNGEN VON CM2

LES APPLICATIONS DE CM2

- + **PAVIMENTAZIONE SOPRAELEVATA SU SUPPORTI REGOLABILI E FISSI**
- + RAISED PAVING ON ADJUSTABLE OR FIXED SUPPORTS
- + BODENABDECKUNGEN AUF EINSTELLBAREN ODER FIXEN STÜTZEN
- + SOL SURÉLEVÉ SUR SUPPORT RÉGLABLES ET FIXES

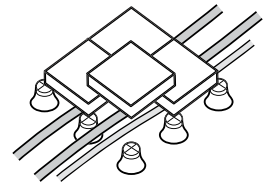

- + **POSA A SECCO SU GHIAIA**
- + DRY INSTALLATION ON GRAVEL
- + TROCKENVERLEGUNG AUF KIES
- + POSE À SEC SUR GRAVIER

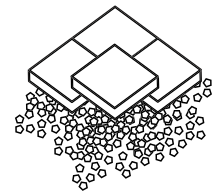

- + **PAVIMENTAZIONE CARRABILE CON POSA TRADIZIONALE SU MASSETTO**
- + DRIVEWAY PAVING ON TRADITIONAL SCREED
- + BEFAHRBARE BODENABDECKUNG, DIE AUF EINER TRADITIONELLEN ZEMENTUNTERLAGE ANGEBRACHT WIRD
- + SOL CARROSSABLE AVEC UNE INSTALLATION TRADITIONNELLE SUR CHAPE

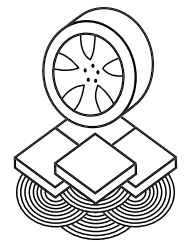

- + **POSA A SECCO SU SABBIA**
- + DRY INSTALLATION ON SAND
- + TROCKENVERLEGUNG AUF SAND
- + POSE À SEC SUR SABLE

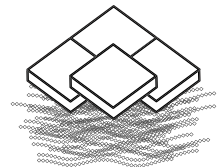

- + **POSA A SECCO SU ERBA**
- + DRY INSTALLATION ON GRASS
- + TROCKENVERLEGUNG AUF GRAS
- + POSE À SEC SUR HERBE

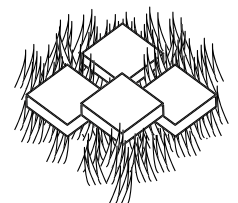

VANTAGGI DEL CM2

ADVANTAGES OF CM2

VORTEILE VON CM2

LES AVANTAGES DE CM2

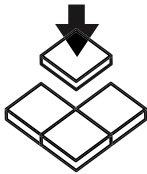

- + Facile da posare anche senza collanti e stucchi;
- + Easy to install even without adhesives or filler;
- + Einfach zu verlegen, auch ohne Klebstoffe oder Mörtel;
- + Facile à installer sans colles ni joints.

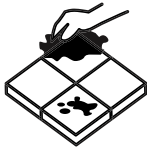

- + Facile da pulire perché non si utilizzano collanti e stucchi;
- + Easy to clean due to the lack of adhesives and filler;
- + Einfach zu reinigen, da keine Klebstoffe oder Mörtel verwendet werden;
- + Facile à nettoyer parce que vous n'utilisez ni colles ni joints.

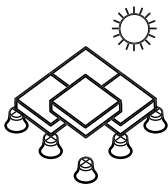

- + Ideale per pavimentazioni in esterno, anche sopraelevate;
- + Ideal for paving outdoor installations, including raised paving;
- + Ideal für Aussenabdeckungen, auch für überlagerte Konstruktionen;
- + Idéal pour les pavages extérieurs, même surélevés.

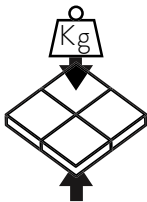

- + Resistente ai carichi di rottura;
- + High tensile strength;
- + Widerstandsfähig gegen Reißfestigkeit;
- + Résistant aux charges de rupture.

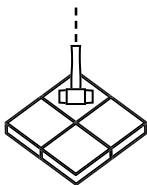

- + Resistente alle sollecitazioni;
- + Stress-resistant;
- + Widerstandsfähig gegen Beanspruchung;
- + Résistant aux sollicitations.



- + Drenante, facilita il deflusso delle acque di meteoriche ed evita ristagni potenzialmente dannosi;
- + Good drainage, facilitates the flow of water and rainfall, eliminating harmful stagnation;
- + Sezernierend, erleichtert den Abfluss bei Niederschlag und verhindert potentiell schädlichen Rückstau;
- + Drainant, il facilite la circulation des eaux de pluie et évite des stagnations potentiellement dangereuses;



- + Antiscivolo (R11 - A+B)
- + Antislip (R11 - A+B)
- + Rutschfest (R11 - A+B)
- + Antidérapant (R11 - A+B)

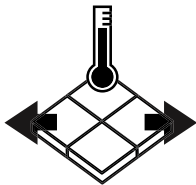

- + Resistente alla dilatazione termica;
- + Highly resistant to changes in temperature;
- + Sehr widerstandsfähig gegen Wärmeausdehnung;
- + Résiste à la dilatation thermique.

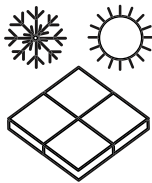

- + Resistente agli agenti atmosferici;
- + Weather resistant;
- + Widerstandsfähig gegen Klimaeinflüsse;
- + Résistant aux agents atmosphériques.

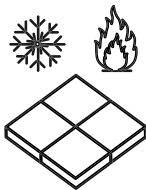

- + Antigelo ed ignifugo;
- + Frost and fire-resistant;
- + Frost- und feuersicher;
- + Résistant au gel et ignifugé.

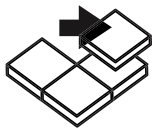

- + Rimovibile e riutilizzabile;
- + Removable and reusable;
- + Auswechselbar und wiederverwendbar;
- + Amovible et réutilisable.

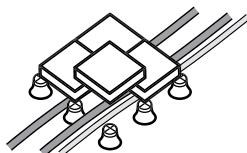

- + Ispezionabile e funzionale, favorisce il passaggio e la manutenzione di impianti di cablaggi e tubazioni;
- + Easily inspected and functional, allows installation and maintenance of cabling and pipework;
- + Überprüfbar und funktionell; ermöglicht die Verlegung und den Unterhalt von Kabelleitungen und Rohrleitungen;
- + Grâce à une inspection facile et fonctionnelle, les dalles favorisent le passage et le maintien des installations de câbles et de tuyaux.



CREMA EUROPA

PIETRE NATURALI
HIGH-TECH



RETTIFICATO MONOCALIBRO

RECTIFIED SINGLE-CALIBRE / REKTIFIZIERT EINKALIBRIG /
RECTIFIÉ MONOCALIBRE

SPESSORE

THICKNESS / DICKE / ÉPAISSEUR

20mm

FORMATI

SIZES / FORMATE / FORMATS

60 x 60 cm
24" x 24"



GREEN QUARZITE

SUPERFICI / SURFACES / OBERFLÄCHEN / SURFACES

STRUTTURATO / STRUCTURED / STRUKTURIERT / STRUCTURÉ

PIETRA PIASENTINA

COEFFICIENTE DI ATTRITO

FRICITION COEFFICIENT
REIBUNGSKOEFFIZIENT
COEFFICIENT DE FROTTEMENT

ST (R11) A+B (CREMA EUROPA)

ST (R11) A+B (GREEN QUARZITE)

ST (R11) A+B (PIETRA PIASENTINA)

FORMATI pag. 354

SIZES pag. 354 / FORMATE pag. 354 / FORMATS pag. 354

PEZZI SPECIALI pag. 354

TRIMS pag. 354 / FORMTEILE pag. 354 / PIÈCES SPÉCIALES pag. 354



PIETRA DI RAGUSA

PIETRE NATURALI
HIGH-TECH



RETTIFICATO MONOCALIBRO

RECTIFIED SINGLE-CALIBRE / REKTIFIZIERT EINKALIBRIG /
RECTIFIÉ MONOCALIBRE

SPESSORE

THICKNESS / DICKE / ÉPAISSEUR

20mm

GREY STONE

FORMATI

SIZES / FORMATE / FORMATS

120 x 60 cm
48" x 24"

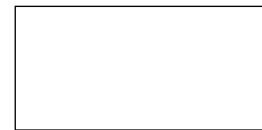

GREY STONE
ABSOLUTE BLACK

60 x 60 cm
24" x 24"

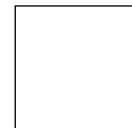

BASALTO GRIGIO

SUPERFICI / SURFACES / OBERFLÄCHEN / SURFACES

STRUTTURATO / STRUCTURED / STRUKTURIERT / STRUCTURÉ

COEFFICIENTE DI ATTRITO

FRICTION COEFFICIENT
REIBUNGSKOEFFIZIENT
COEFFICIENT DE FROTTEMENT

ST (R11) A+B (PIETRA DI RAGUSA)

ST (R11) A+B (GREY STONE)

ST (R11) A+B+C (BASALTO GRIGIO)

ST (R11) A+B (ABSOLUTE BLACK)

ABSOLUTE BLACK

FORMATI pag. 354

SIZES pag. 354 / FORMATE pag. 354 / FORMATS pag. 354

PEZZI SPECIALI pag. 354

TRIMS pag. 354 / FORMTEILE pag. 354 / PIÈCES SPÉCIALES pag. 354



DIORITE

MATERIE
HIGH-TECH



RETTIFICATO MONOCALIBRO

RECTIFIED SINGLE-CALIBRE / REKTIFIZIERT EINKALIBRIG /
RECTIFIÉ MONOCALIBRE

SPESSORE

THICKNESS / DICKE / ÉPAISSEUR

20mm

CENERE

FORMATI

SIZES / FORMATE / FORMATS

120 x 60 cm
48" x 24"



60 x 60 cm
24" x 24"

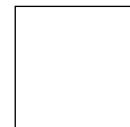

FANGO

SUPERFICI / SURFACES / OBERFLÄCHEN / SURFACES



COEFFICIENTE DI ATTRITO

FRICTION COEFFICIENT
REIBUNGSKOEFFIZIENT
COEFFICIENT DE FROTTEMENT

 (R11) A+B

PELTRO

FORMATI pag. 354

SIZES pag. 354 / FORMATE pag. 354 / FORMATS pag. 354

PEZZI SPECIALI pag. 354

TRIMS pag. 354 / FORMTEILE pag. 354 / PIÈCES SPÉCIALES pag. 354



ROVERE SABBIA

LEGNI HIGH-TECH 



RETTIFICATO MONOCALIBRO

RECTIFIED SINGLE-CALIBRE / REKTIFIZIERT EINKALIBRIG /
RECTIFIÉ MONOCALIBRE

SPESSORE

THICKNESS / DICKE / ÉPAISSEUR

20mm

FORMATI

SIZES / FORMATE / FORMATS

120 x 60 cm
48"x 24"



120 x 30 cm
48"x 12"



ROVERE BRICCOLA

SUPERFICI / SURFACES / OBERFLÄCHEN / SURFACES

ANTICATO / ANTIQUED / ANTIK / ANTIQUE

ROVERE IMPERO

COEFFICIENTE DI ATTRITO

FRICTION COEFFICIENT
REIBUNGSKOEFFIZIENT
COEFFICIENT DE FROTTEMENT

AN (R11) A+B (ROVERE SABBIA)

AN (R11) A+B (ROVERE BRICCOLA)

AN (R11) A+B (ROVERE IMPERO)

FORMATI pag. 354

SIZES pag. 354 / FORMATE pag. 354 / FORMATS pag. 354



ROVERE CENERE

LEGNI HIGH-TECH 



RETTIFICATO MONOCALIBRO

RECTIFIED SINGLE-CALIBRE / REKTIFIZIERT EINKALIBRIG /
RECTIFIÉ MONOCALIBRE

SPESSORE

THICKNESS / DICKE / ÉPAISSEUR

20mm

FORMATI

SIZES / FORMATE / FORMATS

120 x 60 cm
48" x 24"



120 x 30 cm
48" x 12"



ROVERE GRIGIO

SUPERFICI / SURFACES / OBERFLÄCHEN / SURFACES

ANTICATO / ANTIQUED / ANTIK / ANTIQUE

ROVERE TUNDRA

COEFFICIENTE DI ATTRITO

FRICITION COEFFICIENT
REIBUNGSKOEFFIZIENT
COEFFICIENT DE FROTTEMENT

AN (R11) A+B (ROVERE CENERE)

AN (R11) A+B (ROVERE GRIGIO)

AN (R11) A+B (ROVERE TUNDRA)

FORMATI pag. 354

SIZES pag. 354 / FORMATE pag. 354 / FORMATS pag. 354

QUERCIA SHABBY	238
QUERCIA CANADESE	240
QUERCIA BIANCA	242
QUERCIA TROPICALE	244
QUERCIA PETRAEA	246
ROVERE TUNDRA	248
ROVERE PROVENZALE	250
ROVERE CENERE	252
ROVERE SABBIA	254
ROVERE CORDA	256
ROVERE DECAPÉ	258
ROVERE BRICCOLA	260
ROVERE NOCE	262
ROVERE COUNTRY	264
ROVERE IMPERO	266
ROVERE REALE	268
ROVERE MOKA	270
ROVERE GRIGIO	272
ROVERE BIANCO	274
ROVERE NATURALE	276
ROVERE BIONDO	278
ROVERE CILIEGIO	280
ROVERE ANTICO	282
ROVERE ABBAZIA	284
ROVERE NERO	286
WOODRAW ARTIC	288
WOODRAW ASH	290
WOODRAW BOARD	292
WOODRAW POWDER	294
WOODRAW RUST	296



LEGNI HIGH-TECH

LEGNI INNOVATIVE SLABS, HIGH-TECH & WOODRAW



QUERCIA SHABBY

INNOVATIVE SLABS
LEGNI HIGH-TECH 

RETTIFICATO MONOCALIBRO
RECTIFIED SINGLE-CALIBRE / REKTIFIZIERT EINKALIBRIG /
RECTIFIÉ MONOCALIBRE

SPESORE
THICKNESS / DICKE / ÉPAISSEUR

▼
8mm
▲

FORMATI
SIZES / FORMATE / FORMATS

150 x 37,5 cm
60" x 15"



150 x 25 cm
60" x 10"



150x18,7 cm
60" x 8"



SUPERFICI
SURFACES
OBERFLÄCHEN
SURFACES

ANTICATO / ANTIQUED / ANTIK / ANTIQUE

COEFFICIENTE DI ATTRITO
FRICTION COEFFICIENT
REIBUNGSKOEFFIZIENT
COEFFICIENT DE FROTTEMENT

AN (R10) A+B

FORMATI / SIZES / FORMATE / FORMATS
PEZZI SPECIALI / TRIMS / FORMTEILE / PIÈCES SPÉCIALES

pag. 350
pag. 351



QUERCIA CANADESE

INNOVATIVE SLABS
LEGNI HIGH-TECH



RETTIFICATO MONOCALIBRO

RECTIFIED SINGLE-CALIBRE / REKTIFIZIERT EINKALIBRIG /
RECTIFIÉ MONOCALIBRE

SPESSORE

THICKNESS / DICKE / ÉPAISSEUR

8mm

FORMATI

SIZES / FORMATE / FORMATS

150 x 37,5 cm

60" x 15"

150 x 25 cm

60" x 10"

150x18,7 cm

60" x 8"

SUPERFICI

SURFACES
OBERFLÄCHEN
SURFACES

COEFFICIENTE DI ATTRITO

FRICTION COEFFICIENT
REIBUNGSKOEFFIZIENT
COEFFICIENT DE FROTTEMENT

FORMATI / SIZES / FORMATE / FORMATS

PEZZI SPECIALI / TRIMS / FORMTEILE / PIÈCES SPÉCIALES

ANTICATO / ANTIQUED / ANTIK / ANTIQUE

AN (R10) A+B

pag. 350
pag. 351



QUERCIA BIANCA

INNOVATIVE SLABS
LEGGI HIGH-TECH 

RETTIFICATO MONOCALIBRO
RECTIFIED SINGLE-CALIBRE / REKTIFIZIERT EINKALIBRIG /
RECTIFIÉ MONOCALIBRE

SPESSORE
THICKNESS / DICKE / ÉPAISSEUR

▼
8mm
▲

FORMATI
SIZES / FORMATE / FORMATS

150 x 37,5 cm
60" x 15"



150 x 25 cm
60" x 10"



150x18,7 cm
60" x 8"



SUPERFICI
SURFACES
OBERFLÄCHEN
SURFACES

ANTICATO / ANTIQUED / ANTIK / ANTIQUE

COEFFICIENTE DI ATTRITO
FRICTION COEFFICIENT
REIBUNGSKOEFFIZIENT
COEFFICIENT DE FROTTEMENT

AN (R10) A+B

FORMATI / SIZES / FORMATE / FORMATS
PEZZI SPECIALI / TRIMS / FORMTEILE / PIÈCES SPÉCIALES

pag. 350
pag. 351



QUERCIA TROPICALE

INNOVATIVE SLABS
LEGNI HIGH-TECH 

RETTIFICATO MONOCALIBRO
RECTIFIED SINGLE-CALIBRE / REKTIFIZIERT EINKALIBRIG /
RECTIFIÉ MONOCALIBRE

SPESSORE
THICKNESS / DICKE / ÉPAISSEUR

▼
8mm
▲

FORMATI
SIZES / FORMATE / FORMATS

150 x 37,5 cm
60" x 15"

150 x 25 cm
60" x 10"

150x18,7 cm
60" x 8"

SUPERFICI
SURFACES
OBERFLÄCHEN
SURFACES

COEFFICIENTE DI ATTRITO
FRICTION COEFFICIENT
REIBUNGSKOEFFIZIENT
COEFFICIENT DE FROTTEMENT

FORMATI / SIZES / FORMATE / FORMATS
PEZZI SPECIALI / TRIMS / FORMTEILE / PIÈCES SPÉCIALES

ANTICATO / ANTIQUED / ANTIK / ANTIQUE

AN **(R10)** A+B

pag. 350
pag. 351





QUERCIA PETRAEA

INNOVATIVE SLABS
LEGGI HIGH-TECH 

RETTIFICATO MONOCALIBRO
RECTIFIED SINGLE-CALIBRE / REKTIFIZIERT EINKALIBRIG /
RECTIFIÉ MONOCALIBRE

SPESSORE
THICKNESS / DICKE / ÉPAISSEUR

▼
8mm
▲

FORMATI
SIZES / FORMATE / FORMATS

150 x 37,5 cm
60" x 15"

150 x 25 cm
60" x 10"

150x18,7 cm
60" x 8"

SUPERFICI
SURFACES
OBERFLÄCHEN
SURFACES

COEFFICIENTE DI ATTRITO
FRICTION COEFFICIENT
REIBUNGSKOEFFIZIENT
COEFFICIENT DE FROTTEMENT

FORMATI / SIZES / FORMATE / FORMATS
PEZZI SPECIALI / TRIMS / FORMTEILE / PIÈCES SPÉCIALES

ANTICATO / ANTIQUED / ANTIK / ANTIQUE

AN **(R10)** A+B

pag. 350
pag. 351



ROVERE TUNDRA

LEGNI HIGH-TECH 

RETTIFICATO MONOCALIBRO
RECTIFIED SINGLE-CALIBRE / REKTIFIZIERT EINKALBRIG /
RECTIFIÉ MONOCALIBRE

SPESSORE
THICKNESS / DICKE / ÉPAISSEUR

10mm
cm²

FORMATI
SIZES / FORMATE / FORMATS

120 x 30 cm
48" x 12"

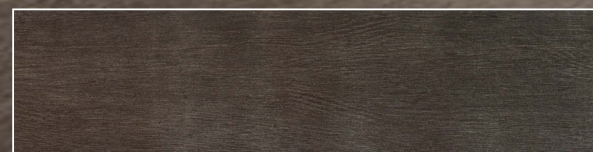

120 x 20 cm
48" x 8"

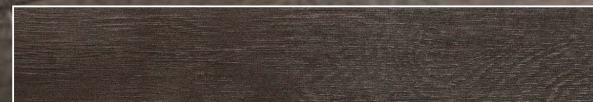

120x15 cm
48" x 6"

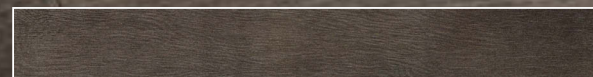

60x10 cm
24" x 4"



SUPERFICI
SURFACES
OBERFLÄCHEN
SURFACES

ANTICATO / ANTIQUED / ANTIK / ANTIQUE

COEFFICIENTE DI ATTRITO
FRICTION COEFFICIENT
REIBUNGSKOEFFIZIENT
COEFFICIENT DE FROTTEMENT

AN (R10) A

FORMATI / SIZES / FORMATE / FORMATS
PEZZI SPECIALI / TRIMS / FORMTEILE / PIÈCES SPÉCIALES
DECORI E MOSAICI / DECORS AND MOSAICS / DEKORE UND MOSAIKE / DECORS ET MOSAÏQUE

pag. 350
pag. 351
pag. 351



ROVERE PROVENZALE

LEGNI HIGH-TECH 

RETTIFICATO MONOCALIBRO
RECTIFIED SINGLE-CALIBRE / REKTIFIZIERT EINKALIBRIG /
RECTIFIÉ MONOCALIBRE

SPESSORE
THICKNESS / DICKE / ÉPAISSEUR

▼
10mm
▲

120 x 30 cm
48" x 12"



120 x 20 cm
48" x 8"



120x15 cm
48" x 6"



60x10 cm
24" x 4"

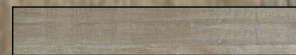

SUPERFICI
SURFACES
OBERFLÄCHEN
SURFACES

ANTICATO / ANTIQUED / ANTIK / ANTIQUE

COEFFICIENTE DI ATTRITO
FRICTION COEFFICIENT
REIBUNGSKOEFFIZIENT
COEFFICIENT DE FROTTEMENT

AN (R10) A+B

FORMATI / SIZES / FORMATE / FORMATS
PEZZI SPECIALI / TRIMS / FORMTEILE / PIÈCES SPÉCIALES

DECORI E MOSAICI / DECORS AND MOSAICS / DEKORE UND MOSAIKE / DECORS ET MOSAÏQUE

pag. 350
pag. 351
pag. 351



ROVERE CENERE

LEGNI HIGH-TECH 

RETTIFICATO MONOCALIBRO
RECTIFIED SINGLE-CALIBRE / REKTIFIZIERT EINKALIBRIG /
RECTIFIÉ MONOCALIBRE

SPESSORE
THICKNESS / DICKE / ÉPAISSEUR

▼
10mm
▲
cm2

FORMATI
SIZES / FORMATE / FORMATS

120 x 30 cm
48" x 12"



120 x 20 cm
48" x 8"



120x15 cm
48" x 6"



60x10 cm
24" x 4"



SUPERFICI
SURFACES
OBERFLÄCHEN
SURFACES

ANTICATO / ANTIQUED / ANTIK / ANTIQUE

COEFFICIENTE DI ATTRITO
FRICTION COEFFICIENT
REIBUNGSKOEFFIZIENT
COEFFICIENT DE FROTTEMENT

AN **(R10)** A+B

FORMATI / SIZES / FORMATE / FORMATS
PEZZI SPECIALI / TRIMS / FORMTEILE / PIÈCES SPÉCIALES
DECORI E MOSAICI / DECORS AND MOSAICS / DEKORE UND MOSAIKE / DECORS ET MOSAIQUE

pag. 350
pag. 351
pag. 351



RETTIFICATO MONOCALIBRO
RECTIFIED SINGLE-CALIBRE / REKTIFIZIERT EINKALIBRIG /
RECTIFIÉ MONOCALIBRE

SPESSORE
THICKNESS / DICKE / ÉPAISSEUR

▼
10mm
▲

cm²

FORMATI
SIZES / FORMATE / FORMATS

120 x 30 cm
48" x 12"



120 x 20 cm
48" x 8"



120x15 cm
48" x 6"



60x10 cm
24" x 4"



SUPERFICI
SURFACES
OBERFLÄCHEN
SURFACES

ANTICATO / ANTIQUED / ANTIK / ANTIQUE

COEFFICIENTE DI ATTRITO
FRICTION COEFFICIENT
REIBUNGSKOEFFIZIENT
COEFFICIENT DE FROTTEMENT

AN **R9** A



RETTIFICATO MONOCALIBRO
RECTIFIED SINGLE-CALIBRE / REKTIFIZIERT EINKALIBRIG /
RECTIFIÉ MONOCALIBRE

SPESSORE
THICKNESS / DICKE / ÉPAISSEUR

▼
10mm
▲

ACTIVE

FORMATI
SIZES / FORMATE / FORMATS

120 x 30 cm
48" x 12"



120 x 20 cm
48" x 8"



120x15 cm
48" x 6"



60x10 cm
24" x 4"



SUPERFICI
SURFACES
OBERFLÄCHEN
SURFACES

ANTICATO / ANTIQUED / ANTIK / ANTIQUE

COEFFICIENTE DI ATTRITO
FRICTION COEFFICIENT
REIBUNGSKOEFFIZIENT
COEFFICIENT DE FROTTEMENT

AN **(R10)** A



ROVERE DECAPÉ

LEGNI HIGH-TECH 

RETTIFICATO MONOCALIBRO
RECTIFIED SINGLE CALIBRE / REKTIFIZIERT EINKALIBRIG /
RECTIFIÉ MONOCALIBRE

SPESSORE
THICKNESS / DICKE / ÉPAISSEUR

▼
10mm
▲

FORMATI
SIZES / FORMATE / FORMATS

120 x 30 cm
48" x 12"

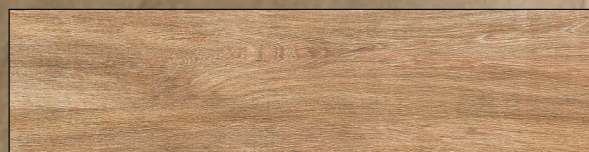

120 x 20 cm
48" x 8"



120x15 cm
48" x 6"



60x10 cm
24" x 4"

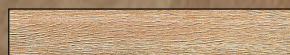

SUPERFICI
SURFACES
OBERFLÄCHEN
SURFACES

ANTICATO / ANTIQUED / ANTIK / ANTIQUE

COEFFICIENTE DI ATRITO
FRICTION COEFFICIENT
REIBUNGSKOEFFIZIENT
COEFFICIENT DE FROTTEMENT

AN (R10) A

FORMATI / SIZES / FORMATE / FORMATS
PEZZI SPECIALI / TRIMS / FORMTEILE / PIÈCES SPÉCIALES
DECORI E MOSAICI / DECORS AND MOSAICS / DEKÖRE UND MOSAIKE / DECORS ET MOSAÏQUE

pag. 350
pag. 351
pag. 351



ROVERE BRICCOLA

LEGNI HIGH-TECH 

RETTIFICATO MONOCALIBRO
RECTIFIED SINGLE-CALIBRE / REKTIFIZIERT EINKALIBRIG /
RECTIFIÉ MONOCALIBRE

SPESSORE
THICKNESS / DICKE / ÉPAISSEUR

10mm

cm²

FORMATI
SIZES / FORMATE / FORMATS

120 x 30 cm
48" x 12"

120 x 20 cm
48" x 8"

120x15 cm
48" x 6"

60x10 cm
24" x 4"

SUPERFICI
SURFACES
OBERFLÄCHEN
SURFACES

ANTICATO / ANTIQUED / ANTIK / ANTIQUE

COEFFICIENTE DI ATTRITO
FRICTION COEFFICIENT
REIBUNGSKOEFFIZIENT
COEFFICIENT DE FROTTEMENT

AN (R11) A+B

FORMATI / SIZES / FORMATE / FORMATS
PEZZI SPECIALI / TRIMS / FORMTEILE / PIÈCES SPÉCIALES
DECORI E MOSAICI / DECORS AND MOSAICS / DEKORE UND MOSAIKE / DECORS ET MOSAÏQUE

pag. 350
pag. 351
pag. 351

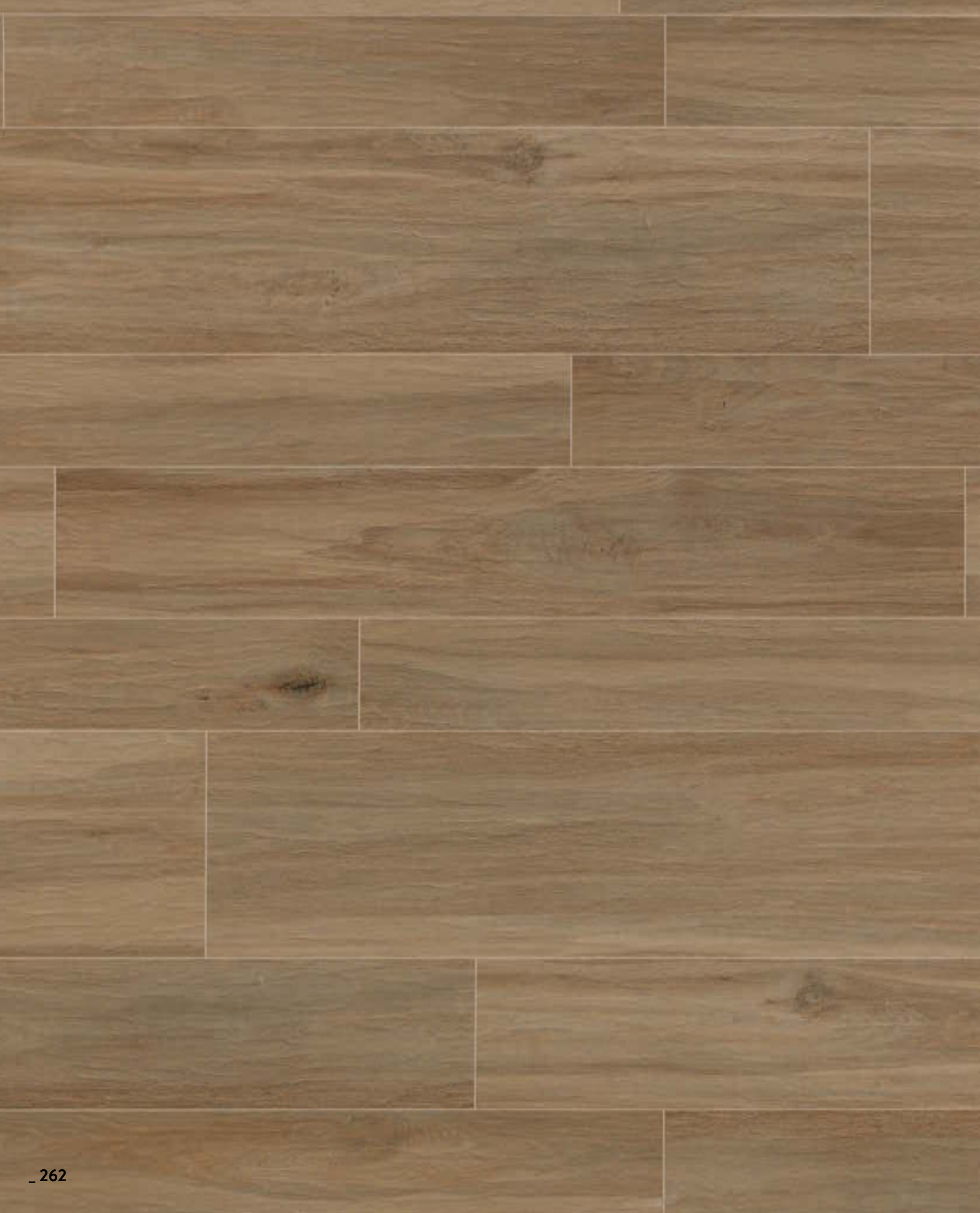

RETTIFICATO MONOCALIBRO
RECTIFIED SINGLE-CALIBRE / REKTIFIZIERT EINKALIBRIG /
RECTIFIÉ MONOCALIBRE

SPESSORE
THICKNESS / DICKE / ÉPAISSEUR

▼
10mm
▲

FORMATI
SIZES / FORMATE / FORMATS

120 x 30 cm
48" x 12"



120 x 20 cm
48" x 8"



120x15 cm
48" x 6"



60x10 cm
24" x 4"



SUPERFICI
SURFACES
OBERFLÄCHEN
SURFACES

ANTICATO / ANTIQUED / ANTIK / ANTIQUE

COEFFICIENTE DI ATTRITO
FRICTION COEFFICIENT
REIBUNGSKOEFFIZIENT
COEFFICIENT DE FROTTEMENT

AN (R10) A+B



RETTIFICATO MONOCALIBRO
RECTIFIED SINGLE-CALIBRE / REKTIFIZIERT EINKALIBRIG /
RECTIFIÉ MONOCALIBRE

SPESSORE
THICKNESS / DICKE / ÉPAISSEUR

▼
10mm
▲

FORMATI
SIZES / FORMATE / FORMATS

120 x 30 cm
48" x 12"

120 x 20 cm
48" x 8"

120x15 cm
48" x 6"

60x10 cm
24" x 4"

SUPERFICI
SURFACES
OBERFLÄCHEN
SURFACES

ANTICATO / ANTIQUED / ANTIK / ANTIQUE

COEFFICIENTE DI ATTRITO
FRICTION COEFFICIENT
REIBUNGSKOEFFIZIENT
COEFFICIENT DE FROTTEMENT

AN **(R10)** A

FORMATI / SIZES / FORMATE / FORMATS
PEZZI SPECIALI / TRIMS / FORMTEILE / PIÈCES SPÉCIALES

DECORI E MOSAICI / DECORS AND MOSAICS / DEKORE UND MOSAIKE / DECORS ET MOSAÏQUE

pag. 350
pag. 351
pag. 351



ROVERE IMPERO

LEGNI HIGH-TECH 

RETTIFICATO MONOCALIBRO
RECTIFIED SINGLE-CALIBRE / REKTIFIZIERT EINKALIBRIG /
RECTIFIÉ MONOCALIBRE

SPESSORE
THICKNESS / DICKE / ÉPAISSEUR

10mm
cm²

FORMATI
SIZES / FORMATE / FORMATS

120 x 30 cm
48" x 12"



120 x 20 cm
48" x 8"



120x15 cm
48" x 6"



60x10 cm
24" x 4"



SUPERFICI
SURFACES
OBERFLÄCHEN
SURFACES

ANTICATO / ANTIQUED / ANTIK / ANTIQUE

COEFFICIENTE DI ATTRITO
FRICTION COEFFICIENT
REIBUNGSKOEFFIZIENT
COEFFICIENT DE FROTTEMENT

AN (R10) A

FORMATI / SIZES / FORMATE / FORMATS
PEZZI SPECIALI / TRIMS / FORMTEILE / PIÈCES SPÉCIALES
DECORI E MOSAICI / DECORS AND MOSAICS / DEKORE UND MOSAIKE / DECORS ET MOSAÏQUE

pag. 350
pag. 351
pag. 351

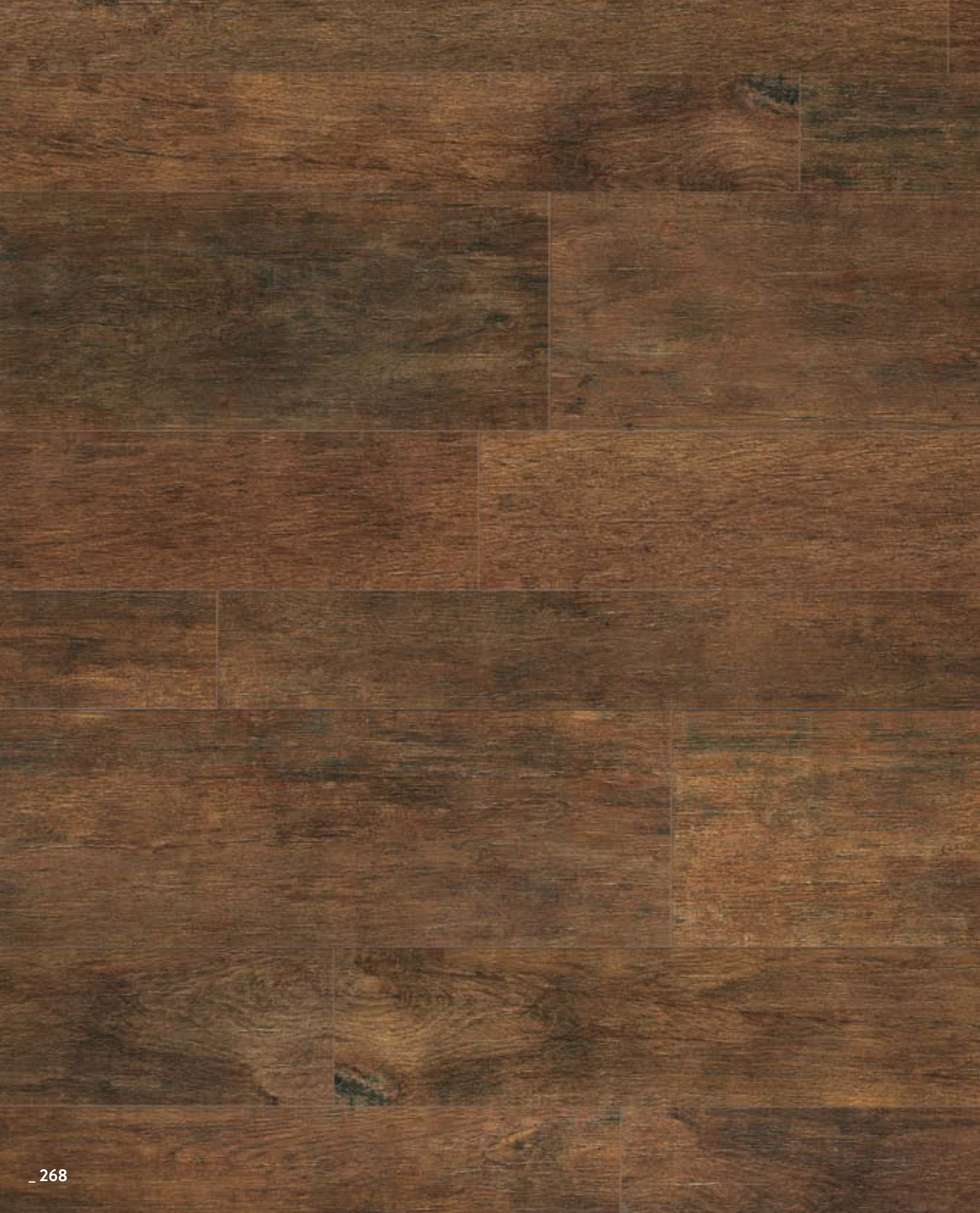

RETTIFICATO MONOCALIBRO
RECTIFIED SINGLE-CALIBRE / REKTIFIZIERT EINKALIBRIG /
RECTIFIÉ MONOCALIBRE

SPESSORE
THICKNESS / DICKE / ÉPAISSEUR

10mm

FORMATI
SIZES / FORMATE / FORMATS

120 x 30 cm
48" x 12"



120 x 20 cm
48" x 8"

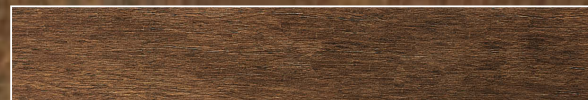

120x15 cm
48" x 6"



60x10 cm
24" x 4"



SUPERFICI
SURFACES
OBERFLÄCHEN
SURFACES

ANTICATO / ANTIQUED / ANTIK / ANTIQUE

COEFFICIENTE DI ATTRITO
FRICTION COEFFICIENT
REIBUNGSKOEFFIZIENT
COEFFICIENT DE FROTTEMENT

AN **(R10)** A



ROVERE MOKA

LEGNI HIGH-TECH 

RETTIFICATO MONOCALIBRO
RECTIFIED SINGLE-CALIBRE / REKTIFIZIERT EINKALIBRIG /
RECTIFIÉ MONOCALIBRE

SPESSORE
THICKNESS / DICKE / ÉPAISSEUR

10mm

ACTIVE

FORMATI
SIZES / FORMATE / FORMATS

90 x 22,5 cm
36" x 9"

90 x 15 cm
36" x 6"

90 x 11 cm
36" x 4^{1/2}"



SUPERFICI
SURFACES
OBERFLÄCHEN
SURFACES

ANTICATO / ANTIQUED / ANTIK / ANTIQUE

COEFFICIENTE DI ATTRITO
FRICTION COEFFICIENT
REIBUNGSKOEFFIZIENT
COEFFICIENT DE FROTTEMENT

AN (R11) A+B

FORMATI / SIZES / FORMATE / FORMATS
PEZZI SPECIALI / TRIMS / FORMTEILE / PIÈCES SPÉCIALES

DECORI E MOSAICI / DECORS AND MOSAICS / DEKORE UND MOSAIKE / DECORS ET MOSAÏQUE

pag. 350
pag. 351
pag. 351

ROVERE GRIGIO

LEGNI HIGH-TECH 

RETTIFICATO MONOCALIBRO
RECTIFIED SINGLE-CALIBRE / REKTIFIZIERT EINKALIBRIG /
RECTIFIÉ MONOCALIBRE

SPESSORE
THICKNESS / DICKE / ÉPAISSEUR

10mm

cm²

ACTIVE

FORMATI
SIZES / FORMATE / FORMATS

90 x 22,5 cm
36" x 9"

90 x 15 cm
36" x 6"

90 x 11 cm
36" x 4^{1/2}"

SUPERFICI
SURFACES
OBERFLÄCHEN
SURFACES

COEFFICIENTE DI ATTRITO
FRICTION COEFFICIENT
REIBUNGSKOEFFIZIENT
COEFFICIENT DE FROTTEMENT

FORMATI / SIZES / FORMATE / FORMATS
PEZZI SPECIALI / TRIMS / FORMTEILE / PIÈCES SPÉCIALES

DECORI E MOSAICI / DECORS AND MOSAICS / DEKORE UND MOSAIKE / DECORS ET MOSAÏQUE

ANTICATO / ANTIQUED / ANTIK / ANTIQUE

AN (R11) A

pag. 350
pag. 351
pag. 351

ROVERE BIANCO

LEGNI HIGH-TECH 

RETTIFICATO MONOCALIBRO
RECTIFIED SINGLE-CALIBRE / REKTIFIZIERT EINKALIBRIG /
RECTIFIÉ MONOCALIBRE

SPESSORE
THICKNESS / DICKE / ÉPAISSEUR

▼
10mm
▲

ACTIVE

FORMATI
SIZES / FORMATE / FORMATS

90 x 22,5 cm
36" x 9"



90 x 15 cm
36" x 6"



90 x 11 cm
36" x 4^{1/2}"



SUPERFICI
SURFACES
OBERFLÄCHEN
SURFACES

ANTICATO / ANTIQUED / ANTIK / ANTIQUE

COEFFICIENTE DI ATTRITO
FRICTION COEFFICIENT
REIBUNGSKOEFFIZIENT
COEFFICIENT DE FROTTEMENT

AN **(R10)** A+B+C

FORMATI / SIZES / FORMATE / FORMATS
PEZZI SPECIALI / TRIMS / FORMTEILE / PIÈCES SPÉCIALES
DECORI E MOSAICI / DECORS AND MOSAICS / DEKÖRE UND MOSAIKE / DECORS ET MOSAÏQUE

pag. 350
pag. 351
pag. 351



ROVERE NATURALE

LEGNI HIGH-TECH 

RETTIFICATO MONOCALIBRO
RECTIFIED SINGLE-CALIBRE / REKTIFIZIERT EINKALIBRIG /
RECTIFIÉ MONOCALIBRE

SPESSORE
THICKNESS / DICKE / ÉPAISSEUR

▼
10mm
▲

ACTIVE

FORMATI
SIZES / FORMATE / FORMATS

90 x 22,5 cm
36" x 9"



90 x 15 cm
36" x 6"



90 x 11 cm
36" x 4^{1/2}"



SUPERFICI
SURFACES
OBERFLÄCHEN
SURFACES

ANTICATO / ANTIQUED / ANTIK / ANTIQUE

COEFFICIENTE DI ATTRITO
FRICTION COEFFICIENT
REIBUNGSKOEFFIZIENT
COEFFICIENT DE FROTTEMENT

AN **(R10)** A+B

FORMATI / SIZES / FORMATE / FORMATS
PEZZI SPECIALI / TRIMS / FORMTEILE / PIÈCES SPÉCIALES
DECORI E MOSAICI / DECORS AND MOSAICS / DEKORE UND MOSAIKE / DECORS ET MOSAIQUE

pag. 350
pag. 351
pag. 351

ROVERE BIONDO

LEGNI HIGH-TECH 

RETTIFICATO MONOCALIBRO
RECTIFIED SINGLE-CALIBRE / REKTIFIZIERT EINKALIBRIG /
RECTIFIÉ MONOCALIBRE

SPESSORE
THICKNESS / DICKE / ÉPAISSEUR

10mm

ACTIVE

FORMATI
SIZES / FORMATE / FORMATS

90 x 22,5 cm
36" x 9"



90 x 15 cm
36" x 6"

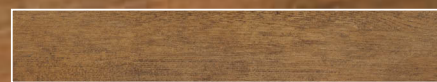

90 x 11 cm
36" x 4^{1/2}"



SUPERFICI
SURFACES
OBERFLÄCHEN
SURFACES

ANTICATO / ANTIQUED / ANTIK / ANTIQUE

COEFFICIENTE DI ATTRITO
FRICTION COEFFICIENT
REIBUNGSKOEFFIZIENT
COEFFICIENT DE FROTTEMENT

AN (R9) A

FORMATI / SIZES / FORMATE / FORMATS
PEZZI SPECIALI / TRIMS / FORMTEILE / PIÈCES SPÉCIALES
DECORI E MOSAICI / DECORS AND MOSAICS / DEKORE UND MOSAIKE / DECORS ET MOSAÏQUE

pag. 350
pag. 351
pag. 351

ROVERE CILIEGIO

LEGNI HIGH-TECH 

RETTIFICATO MONOCALIBRO
RECTIFIED SINGLE-CALIBRE / REKTIFIZIERT EINKALIBRIG /
RECTIFIÉ MONOCALIBRE

SPESSORE
THICKNESS / DICKE / ÉPAISSEUR

10mm

FORMATI
SIZES / FORMATE / FORMATS

90 x 22,5 cm
36" x 9"

90 x 15 cm
36" x 6"

90 x 11 cm
36" x 4^{1/2}"

SUPERFICI
SURFACES
OBERFLÄCHEN
SURFACES

COEFFICIENTE DI ATTRITO
FRICTION COEFFICIENT
REIBUNGSKOEFFIZIENT
COEFFICIENT DE FROTTEMENT

FORMATI / SIZES / FORMATE / FORMATS
PEZZI SPECIALI / TRIMS / FORMTEILE / PIÈCES SPÉCIALES
DECORI E MOSAICI / DECORS AND MOSAICS / DEKORE UND MOSAIKE / DECORS ET MOSAÏQUE

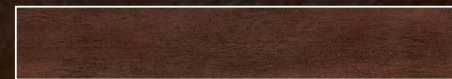
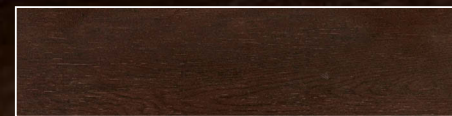

ANTICATO / ANTIQUED / ANTIK / ANTIQUE

AN **(R10)** A+B

pag. 350
pag. 351
pag. 351

ROVERE ANTICO

LEGNI HIGH-TECH 

RETTIFICATO MONOCALIBRO
RECTIFIED SINGLE-CALIBRE / REKTIFIZIERT EINKALIBRIG /
RECTIFIÉ MONOCALIBRE

SPESSORE
THICKNESS / DICKE / ÉPAISSEUR

10mm

FORMATI
SIZES / FORMATE / FORMATS

90 x 22,5 cm
36" x 9"

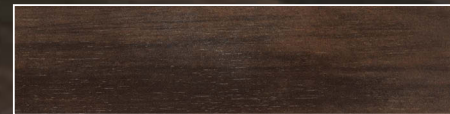

90 x 15 cm
36" x 6"

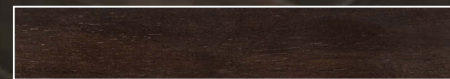

90 x 11 cm
36" x 4 1/2"

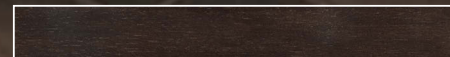

SUPERFICI
SURFACES
OBERFLÄCHEN
SURFACES

ANTICATO / ANTIQUED / ANTIK / ANTIQUE

COEFFICIENTE DI ATTRITO
FRICTION COEFFICIENT
REIBUNGSKOEFFIZIENT
COEFFICIENT DE FROTTEMENT

AN **(R10)** A

FORMATI / SIZES / FORMATE / FORMATS
PEZZI SPECIALI / TRIMS / FORMTEILE / PIÈCES SPÉCIALES

DECORI E MOSAICI / DECORS AND MOSAICS / DEKORE UND MOSAIKE / DECORS ET MOSAIQUE

pag. 350
pag. 351
pag. 351

ROVERE ABBAZIA

LEGNI HIGH-TECH 

RETTIFICATO MONOCALIBRO
RECTIFIED SINGLE-CALIBRE / REKTIFIZIERT EINKALIBRIG /
RECTIFIÉ MONOCALIBRE

SPESSORE
THICKNESS / DICKE / ÉPAISSEUR

10mm

FORMATI
SIZES / FORMATE / FORMATS

90 x 22,5 cm
36" x 9"

90 x 15 cm
36" x 6"

90 x 11 cm
36" x 4^{1/2}"

SUPERFICI
SURFACES
OBERFLÄCHEN
SURFACES

ANTICATO / ANTIQUED / ANTIK / ANTIQUE

COEFFICIENTE DI ATTRITO
FRICTION COEFFICIENT
REIBUNGSKOEFFIZIENT
COEFFICIENT DE FROTTEMENT

AN (R10) A

FORMATI / SIZES / FORMATE / FORMATS
PEZZI SPECIALI / TRIMS / FORMTEILE / PIÈCES SPÉCIALES

DECORI E MOSAICI / DECORS AND MOSAICS / DEKORE UND MOSAIKE / DECORS ET MOSAÏQUE

pag. 350
pag. 351
pag. 351

ROVERE NERO

LEGNI HIGH-TECH 

RETTIFICATO MONOCALIBRO
RECTIFIED SINGLE-CALIBRE / REKTIFIZIERT EINKALIBRIG /
RECTIFIÉ MONOCALIBRE

SPESSORE
THICKNESS / DICKE / ÉPAISSEUR

▼
10mm
▲

FORMATI
SIZES / FORMATE / FORMATS

90 x 22,5 cm
36" x 9"



90 x 15 cm
36" x 6"



90 x 11 cm
36" x 4 1/2"



SUPERFICI
SURFACES
OBERFLÄCHEN
SURFACES

ANTICATO / ANTIQUED / ANTIK / ANTIQUE

COEFFICIENTE DI ATTRITO
FRICTION COEFFICIENT
REIBUNGSKOEFFIZIENT
COEFFICIENT DE FROTTEMENT

AN (R11) A+B+C

FORMATI / SIZES / FORMATE / FORMATS
PEZZI SPECIALI / TRIMS / FORMTEILE / PIÈCES SPÉCIALES

DECORI E MOSAICI / DECORS AND MOSAICS / DEKORE UND MOSAIKE / DECORS ET MOSAÏQUE

pag. 350
pag. 351
pag. 351

ARTIC

WOODDRAW

RETTIFICATO MONOCALIBRO

RECTIFIED SINGLE-CALIBRE / REKTIFIZIERT EINKALIBRIG /
RECTIFIÉ MONOCALIBRE

SPESSORE

THICKNESS / DICKE / ÉPAISSEUR

▼
8 mm
▲

FORMATI

SIZES / FORMATE / FORMATS

120 x 20 cm

48" x 8"

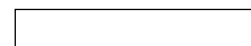

SUPERFICI / SURFACES / OBERFLÄCHEN / SURFACES

ANTICATO / ANTIQUED / ANTIK / ANTIQUE

COEFFICIENTE DI ATTRITO

FRICION COEFFICIENT
REIBUNGSKOEFFIZIENT
COEFFICIENT DE FROTTEMENT

AN (R9)

FORMATI pag. 351

SIZES pag. 351 / FORMATE pag. 351 / FORMATS pag. 351



ASH

WOODDRAW

RETTIFICATO MONOCALIBRO

RECTIFIED SINGLE-CALIBRE / REKTIFIZIERT EINKALIBRIG /
RECTIFIÉ MONOCALIBRE

SPESSORE

THICKNESS / DICKE / ÉPAISSEUR

$\frac{\text{8 mm}}{\text{▲}}$

FORMATI

SIZES / FORMATE / FORMATS

120 x 20 cm

48" x 8"



SUPERFICI / SURFACES / OBERFLÄCHEN / SURFACES

ANTICATO / ANTIQUED / ANTIK / ANTIQUE

COEFFICIENTE DI ATTRITO

FRICITION COEFFICIENT

REIBUNGSKOEFFIZIENT

COEFFICIENT DE FROTTEMENT

AN (R9)

FORMATI pag. 351

SIZES pag. 351 / FORMATE pag. 351 / FORMATS pag. 351



BOARD

WOODRAW

RETTIFICATO MONOCALIBRO

RECTIFIED SINGLE-CALIBRE / REKTIFIZIERT EINKALIBRIG /
RECTIFIÉ MONOCALIBRE

SPESSORE

THICKNESS / DICKE / ÉPAISSEUR

▼
8 mm
▲

FORMATI

SIZES / FORMATE / FORMATS

120 x 20 cm

48" x 8"



SUPERFICI / SURFACES / OBERFLÄCHEN / SURFACES

ANTICATO / ANTIQUED / ANTIK / ANTIQUE

COEFFICIENTE DI ATTRITO

FRICITION COEFFICIENT

REIBUNGSKOEFFIZIENT

COEFFICIENT DE FROTTEMENT

AN (R9)

FORMATI pag. 351

SIZES pag. 351 / FORMATE pag. 351 / FORMATS pag. 351



POWDER

WOODRAW

RETTIFICATO MONOCALIBRO

RECTIFIED SINGLE-CALIBRE / REKTIFIZIERT EINKALIBRIG /
RECTIFIÉ MONOCALIBRE

SPESSORE

THICKNESS / DICKE / ÉPAISSEUR

$\frac{\text{8 mm}}{\text{▲}}$

FORMATI

SIZES / FORMATE / FORMATS

120 x 20 cm

48" x 8"

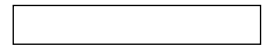

SUPERFICI / SURFACES / OBERFLÄCHEN / SURFACES

ANTICATO / ANTIQUED / ANTIK / ANTIQUE

COEFFICIENTE DI ATTRITO

FRICITION COEFFICIENT

REIBUNGSKOEFFIZIENT

COEFFICIENT DE FROTTEMENT

AN (R9)

FORMATI pag. 351

SIZES pag. 351 / FORMATE pag. 351 / FORMATS pag. 351



RUST

WOODRAW

RETTIFICATO MONOCALIBRO

RECTIFIED SINGLE-CALIBRE / REKTIFIZIERT EINKALIBRIG /
RECTIFIÉ MONOCALIBRE

SPESSORE

THICKNESS / DICKE / ÉPAISSEUR

$\frac{8\text{ mm}}{\triangle}$

FORMATI

SIZES / FORMATE / FORMATS

120 x 20 cm

48" x 8"

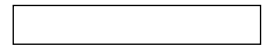

SUPERFICI / SURFACES / OBERFLÄCHEN / SURFACES

ANTICATO / ANTIQUED / ANTIK / ANTIQUE

COEFFICIENTE DI ATTRITO

FRICITION COEFFICIENT

REIBUNGSKOEFFIZIENT

COEFFICIENT DE FROTTEMENT

AN (R9)

FORMATI pag. 351

SIZES pag. 351 / FORMATE pag. 351 / FORMATS pag. 351

IRIDIUM

NERO

IRIDIUM

BROWN

RETTIFICATO MONOCALIBRO

RECTIFIED SINGLE-CALIBRE / REKTIFIZIERT EINKALIBRIG /
RECTIFIÉ MONOCALIBRE

SPESSORE

THICKNESS / DICKE / ÉPAISSEUR

$\frac{\nabla}{10\text{mm}}$
 \blacktriangle

FORMATI

SIZES / FORMATE / FORMATS

60 x 60 cm
24" x 24"

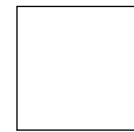

60 x 30 cm
24" x 12"

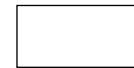

60 x 9 cm
24" x 3^{3/5}"

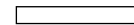

CHAMPAGNE

BIANCO

SUPERFICI / SURFACES / OBERFLÄCHEN / SURFACES

LEVIGATO E LUCIDATO / HONED AND POLISHED /
GESCHLIFFEN UND POLIERT / POLI ET LUSTRÉ

SOFT

GRIGIO

COEFFICIENTE DI ATTRITO

FRICITION COEFFICIENT
REIBUNGSKOEFFIZIENT
COEFFICIENT DE FROTTEMENT

FORMATI pag. 352

SIZES pag. 352 / FORMATE pag. 352 / FORMATS pag. 352

PEZZI SPECIALI pag. 352

TRIMS pag. 352 / FORMTEILE pag. 352 / PIÈCES SPÉCIALES pag. 352

DECORI E MOSAICI pag. 352

DECORS AND MOSAICS pag. 352
DEKORE UND MOSAIKE pag. 352
DECORS ET MOSAIQUE pag. 352

VERDE



SKY

IRIDIUM

BLU

RETTIFICATO MONOCALIBRO

RECTIFIED SINGLE-CALIBRE / REKTIFIZIERT EINKALIBRIG /
RECTIFIÉ MONOCALIBRE

SPESSORE

THICKNESS / DICKE / ÉPAISSEUR

10mm

FORMATI

SIZES / FORMATE / FORMATS

60 x 60 cm
24" x 24"



60 x 30 cm
24" x 12"



60 x 9 cm
24" x 3³/₅"

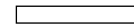

VIOLET

ROSSO

ARANCIO

GIALLO

SUPERFICI / SURFACES / OBERFLÄCHEN / SURFACES

**LEVIGATO E LUCIDATO / HONED AND POLISHED /
GESCHLIFFEN UND POLIERT / POLI ET LUSTRÉ**

SOFT

COEFFICIENTE DI ATTRITO

FRICITION COEFFICIENT
REIBUNGSKOEFFIZIENT
COEFFICIENT DE FROTTEMENT

FORMATI pag. 352

SIZES pag. 352 / FORMATE pag. 352 / FORMATS pag. 352

PEZZI SPECIALI pag. 352

TRIMS pag. 352 / FORMTEILE pag. 352 / PIÈCES SPÉCIALES pag. 352

DECORI E MOSAICI pag. 352

DECORS AND MOSAICS pag. 352
DEKORE UND MOSAIKE pag. 352
DECORS ET MOSAIQUE pag. 352

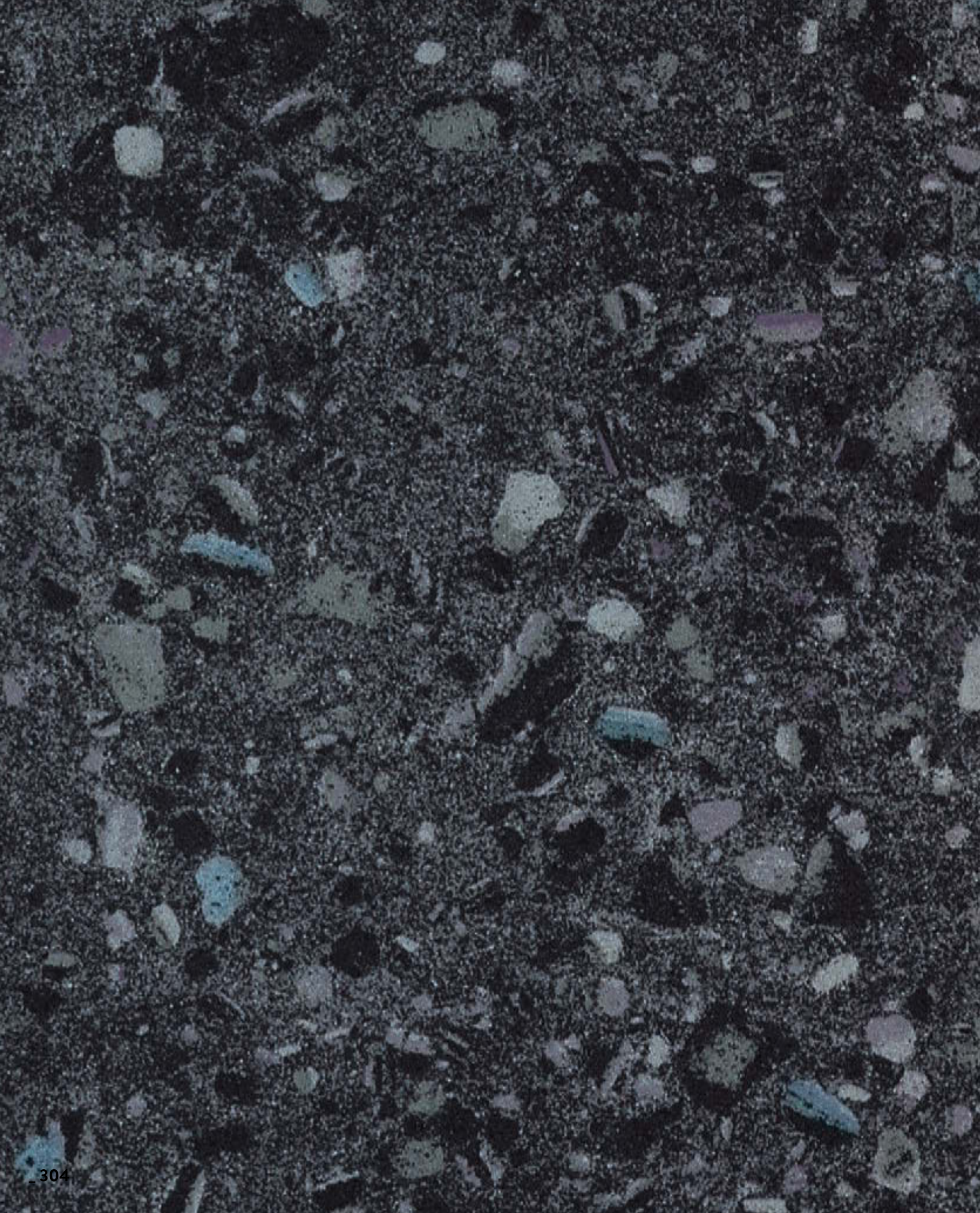



STARDUST 306

PORFIDO 310

TECNOPORCELAIN

STARDUST & PORFIDO

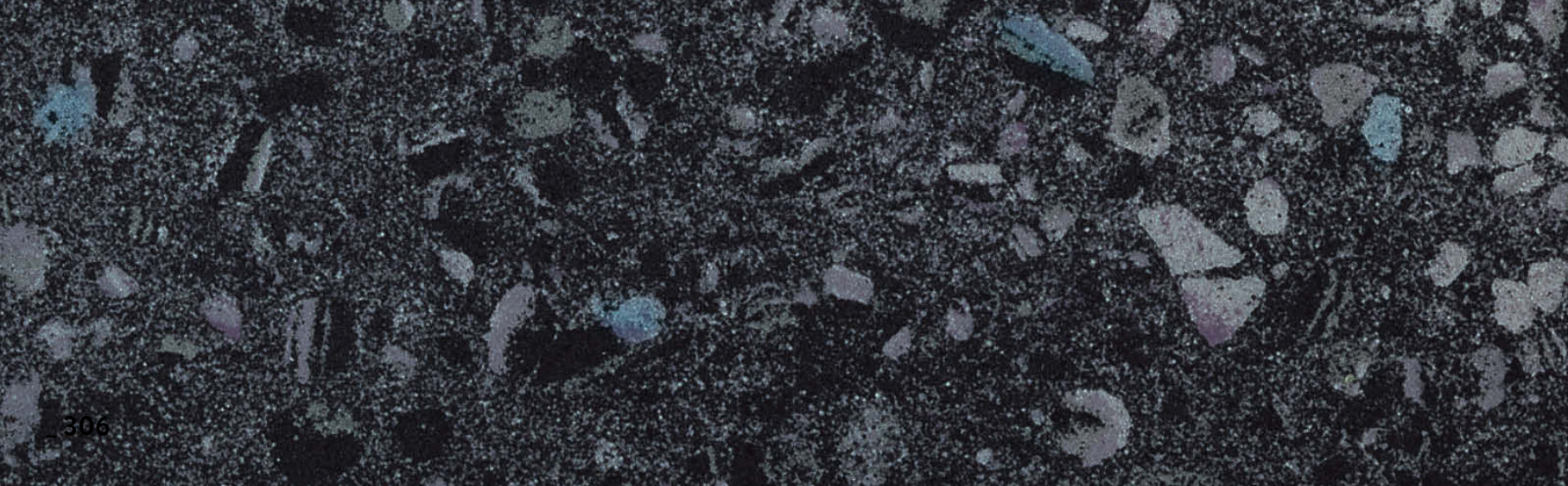

BRIQUE

STARDUST

RETTIFICATO MONOCALIBRO

RECTIFIED SINGLE-CALIBRE / REKTIFIZIERT EINKALIBRIG /
RECTIFIÉ MONOCALIBRE

SPESSORE

THICKNESS / DICKE / ÉPAISSEUR

▼
9mm
▲

PASTEL

FORMATI

SIZES / FORMATE / FORMATS

40 x 40 cm

16" x 16"

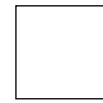

40 x 9 cm

16" x 3³/₅"

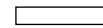

30 x 30 cm

12" x 12"



30 x 9 cm

12" x 3³/₅"



FUMÉ

SUPERFICI / SURFACES / OBERFLÄCHEN / SURFACES

LEVIGATO E LUCIDATO / HONED AND POLISHED /
GESCHLIFFEN UND POLIERT / POLI ET LUSTRÉ

PRELEVIGATO / PREPOLISHED / VORGESCHLIFFEN / PRÉPOLI

COEFFICIENTE DI ATTRITO

FRICITION COEFFICIENT
REIBUNGSKOEFFIZIENT
COEFFICIENT DE FROTTEMENT

PR (R9)

FORMATI pag. 354

SIZES pag. 354 / FORMATE pag. 354 / FORMATS pag. 354

PEZZI SPECIALI pag. 354

TRIMS pag. 354 / FORMTEILE pag. 354 / PIÈCES SPÉCIALES pag. 354

NOIR

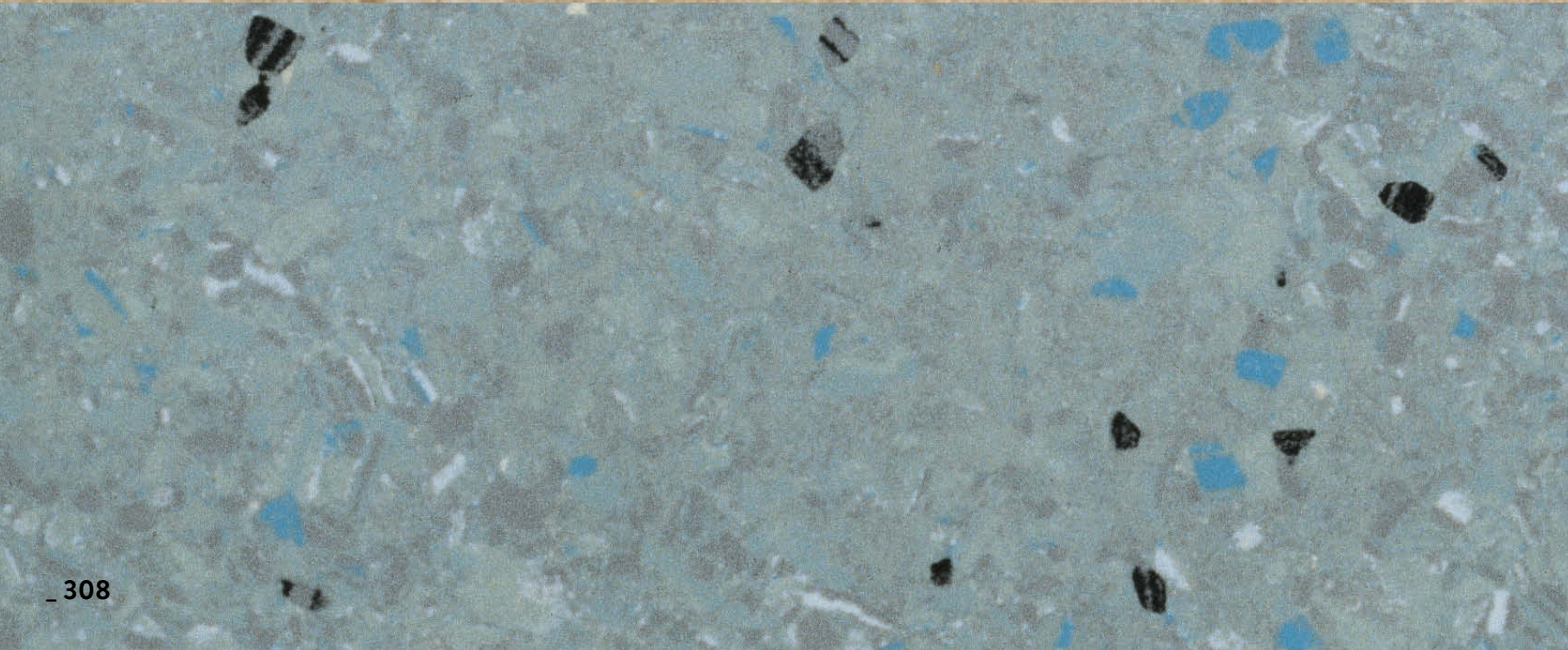

ARGENTÉ

STARDUST

RETTIFICATO MONOCALIBRO

RECTIFIED SINGLE-CALIBRE / REKTIFIZIERT EINKALIBRIG /
RECTIFIÉ MONOCALIBRE

SPESSORE

THICKNESS / DICKE / ÉPAISSEUR

▼
9mm
▲

FORMATI

SIZES / FORMATE / FORMATS

30 x 30 cm

12" x 12"



30 x 9 cm

12" x 3³/₅"



SABLE

SUPERFICI / SURFACES / OBERFLÄCHEN / SURFACES

LEVIGATO E LUCIDATO / HONED AND POLISHED /
GESCHLIFFEN UND POLIERT / POLI ET LUSTRÉ

PRELEVIGATO / PREPOLISHED / VORGESCHLIFFEN / PRÉPOLI

COBALT

COEFFICIENTE DI ATTRITO

FRICITION COEFFICIENT
REIBUNGSKOEFFIZIENT
COEFFICIENT DE FROTTEMENT

PR (R9)

FORMATI pag. 354

SIZES pag. 354 / FORMATE pag. 354 / FORMATS pag. 354

PEZZI SPECIALI pag. 354

TRIMS pag. 354 / FORMTEILE pag. 354 / PIÈCES SPÉCIALES pag. 354



TAMPA

PORFIDO

SPESSORE pag. 353 / THICKNESS pag. 353 / DICKE pag. 353 /
EPAISSEUR pag. 353

FORMATI

SIZES / FORMATE / FORMATS

40 x 40 cm

16" x 16"

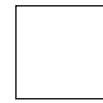

30 x 30 cm

12" x 12"



30 x 9 cm

12" x 3³/₅"



20 x 20 cm

8" x 8"



DETROIT

SUPERFICI / SURFACES / OBERFLÄCHEN / SURFACES

LEVIGATO E LUCIDATO / HONED AND POLISHED /
GESCHLIFFEN UND POLIERT / POLI ET LUSTRÉ

NATURALE / NATURAL / NATURBELASSEN / NATUREL

STRUTTURATO / STRUCTURED / STRUKTURIERT / STRUCTURÉ

TEXAS

COEFFICIENTE DI ATTRITO

FRICTION COEFFICIENT

REIBUNGSKOEFFIZIENT

COEFFICIENT DE FROTTEMENT

N **R9** A

ST **R11** A

FORMATI pag. 353

SIZES pag. 353 / FORMATE pag. 353 / FORMATS pag. 353

PEZZI SPECIALI pag. 353

TRIMS pag. 353 / FORMTEILE pag. 353 / PIÈCES SPÉCIALES pag. 353



SEATTLE

PORFIDO

SPESORE pag. 353 / THICKNESS pag. 353 / DICKE pag. 353 /
EPAISSEUR pag. 353

FORMATI

SIZES / FORMATE / FORMATS

30 x 30 cm
12" x 12"



30 x 9 cm
12" x 3³/₅"



20 x 20 cm
8" x 8"



HOUSTON

SUPERFICI / SURFACES / OBERFLÄCHEN / SURFACES

LEVIGATO E LUCIDATO / HONED AND POLISHED /
GESCHLIFFEN UND POLIERT / POLI ET LUSTRÉ

NATURALE / NATURAL / NATURBELASSEN / NATUREL

STRUTTURATO / STRUCTURED / STRUKTURIERT / STRUCTURÉ

NEVADA

COEFFICIENTE DI ATTRITO

FRICITION COEFFICIENT
REIBUNGSKOEFFIZIENT
COEFFICIENT DE FROTTEMENT

N (R9) A

ST (R11) A

FORMATI pag. 353

SIZES pag. 353 / FORMATE pag. 353 / FORMATS pag. 353

PEZZI SPECIALI pag. 353

TRIMS pag. 353 / FORMTEILE pag. 353 / PIÈCES SPÉCIALES pag. 353



CRYSTAL

PORFIDO

SPESORE pag. 353 / THICKNESS pag. 353 / DICKE pag. 353 /
EPAISSEUR pag. 353

FORMATI

SIZES / FORMATE / FORMATS

30 x 30 cm

12" x 12"



20 x 20 cm

8" x 8"



KANSAS

SUPERFICI / SURFACES / OBERFLÄCHEN / SURFACES

NATURALE / NATURAL / NATURBELASSEN / NATUREL

OREGON

COEFFICIENTE DI ATTRITO

FRICITION COEFFICIENT

REIBUNGSKOEFFIZIENT

COEFFICIENT DE FROTTEMENT

N  A

FORMATI pag. 353

SIZES pag. 353 / FORMATE pag. 353 / FORMATS pag. 353

PEZZI SPECIALI pag. 353

TRIMS pag. 353 / FORMTEILE pag. 353 / PIÈCES SPÉCIALES pag. 353



ALASKA

PORFIDO

SPESORE pag. 353 / THICKNESS pag. 353 / DICKE pag. 353 /
EPAISSEUR pag. 353

FORMATI

SIZES / FORMATE / FORMATS

30 x 30 cm
12" x 12"



20 x 20 cm
8" x 8"



BETEL

SUPERFICI / SURFACES / OBERFLÄCHEN / SURFACES

NATURALE / NATURAL / NATURBELASSEN / NATUREL

STRUTTURATO / STRUCTURED / STRUKTURIERT / STRUCTURÉ

TUCSON

COEFFICIENTE DI ATTRITO

FRICTION COEFFICIENT
REIBUNGSKOEFFIZIENT
COEFFICIENT DE FROTTEMENT

N (R9) A

ST (R11) A

FORMATI pag. 353

SIZES pag. 353 / FORMATE pag. 353 / FORMATS pag. 353

PEZZI SPECIALI pag. 353

TRIMS pag. 353 / FORMTEILE pag. 353 / PIÈCES SPÉCIALES pag. 353



CREAM

UNIVERSE

HONEY

RETTIFICATO MONOCALIBRO

RECTIFIED SINGLE-CALIBRE / REKTIFIZIERT EINKALIBRIG / RECTIFIÉ MONOCALIBRE

SPESSORE

THICKNESS / DICKE / ÉPAISSEUR

▼
9mm
▲

FORMATI

SIZES / FORMATE / FORMATS

60 x 60 cm
24"x 24"



60 x 30 cm
24"x 12"



60 x 15 cm
24"x 6"

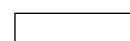

60 x 10 cm
24"x 4"

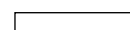

BROWN

MIST GREY

NIGHT BLUE

SUPERFICI / SURFACES / OBERFLÄCHEN / SURFACES

SATINATO / SATIN-FINISH / SATINIERT / SATINÉ

BOCCIARDATO / BUSHHAMMERED / GESTOCKT / BOUCHARDÉ

HIGH HONED

COEFFICIENTE DI ATTRITO

FRICITION COEFFICIENT
REIBUNGSKOEFFIZIENT
COEFFICIENT DE FROTTEMENT

SA (R10) A

BC (R11) A+B+C

FORMATI pag. 352

SIZES pag. 352 / FORMATE pag. 352 / FORMATS pag. 352

PEZZI SPECIALI pag. 352

TRIMS pag. 352 / FORMTEILE pag. 352 / PIÈCES SPÉCIALES pag. 352

DECORI E MOSAICI pag. 352

DECORS AND MOSAICS pag. 352
DEKORE UND MOSAIKE pag. 352
DECORS ET MOSAÏQUE pag. 352

OBSIDIAN



LA POSA /
INSTALLATION /
DIE VERLEGUNG /
LA POSE

LA POSA Alla totale riuscita di un pavimento Ariostea concorrono, insieme alle qualità tecniche ed estetiche del materiale, elementi quali sottofondo, strato legante, giunti di dilatazione, che costituiscono un vero e proprio sistema pavimento. Solo la corretta esecuzione delle operazioni di posa assicura un perfetto risultato finale.

La posa deve essere preferibilmente eseguita con collanti idonei, attenendosi alle istruzioni della ditta produttrice degli stessi.

Nei luoghi ad elevato transito o con passaggio di carichi pesanti è consigliabile il sistema a doppia spalmatura.

I materiali Ariostea tendono a simulare la casualità della natura con le sue

variazioni cromatiche, che l'abilità del posatore può esaltare. Per valorizzare al meglio le caratteristiche del materiale, si consiglia di seguire, durante la posa in opera, le seguenti prescrizioni:

- Stendere a terra alcuni pezzi (almeno 3 mq.) per controllare l'effetto d'insieme. Posare il materiale attingendone da più scatole.
- Non immergere in acqua il materiale prima della posa.
- Soprattutto nelle superfici levigate, per i tagli non segnare la parte superiore da posare con matite o pennarelli.
- Attendere 48-72 ore prima di sottoporre il pavimento al normale transito.

INSTALLATION In addition to the technical and aesthetic qualities of the material used, the total success of an Ariostea floor installation depends on a series of elements such as bed, adhesive layer and expansion joints, which make up a true flooring system. A correct installation is therefore essential in order to ensure perfect final results.

The installation should be preferably made using proper adhesives, following the instructions provided by the manufacturer.

In places subject to heavy traffic or to the passage of heavy loads it is advisable to perform installation at double spread.

Ariostea products tend to replicate the random appearance of natural materials, with their characteristic colour variations, which the skills of the installer can even enhance. Follow these instructions to bring out the best in the material:

- Spread out a number of pieces (at least 3 square metres) on the floor to check the overall effect. When laying the material, mix contents of different boxes.
- Do not immerse the material in water before laying.
- With polished surfaces in particular, do not mark the up per surfaces with pencils or marker pens where cut are needed.
- Wait 48-72 hours before subjecting the floor to normal use.

DIE VERLEGUNG Das perfekte Gelingen eines Bodenbelags von Ariostea hängt außer von den technischen und ästhetischen Materialeigenschaften auch von einer Reihe anderer Faktoren ab: Untergrund, Bindschicht, Dehnungsfugen. Diese bilden ein regelrechtes Fußbodensystem. Nur durch eine fachgerechte Verlegung kann daher ein optimales Endergebnis erzielt werden. Die Verlegung muss am besten mit geeigneten Klebstoffen erfolgen, und es wird angeraten, die Angaben des jeweiligen Herstellers genau zu befolgen. In Räumen mit hoher Begehungsfrequenz oder bei Beanspruchung durch schwere Lasten empfiehlt sich die Verlegung an doppelter Ausbreitung. Die Fliesen von Ariostea haben die Neigung, die für Naturprodukte typische Zufälligkeit mit ihren Farbvariationen nachzubilden, die ein guter Fliesenleger

bei seiner Arbeit zu nutzen weiß.

Um die Materialeigenschaften am besten zur Geltung zu bringen, wird empfohlen, während der Verlegung vor Ort die folgenden Hinweise zu befolgen:

- Legen Sie einige Fliesen (mind. 3 m²) auf dem Boden aus, um die Gesamtwirkung zu testen. Entnehmen Sie das Material aus verschiedenen Kartons.
- Legen Sie das Material vor dem Verlegen nicht in Wasser.
- Vor allem bei polierten Oberflächenausführungen vermeiden Sie, den Schnittverlauf an der zu verlegenden Materialoberfläche mit Bleistift oder Filzstift aufzuzeichnen.
- Die normale Begehungsfrequenz wird nur nach 48-72 Stunden erlaubt.

LA POSE La réussite totale d'un sol Ariostea dépend non seulement des qualités techniques et esthétiques du matériau mais aussi de divers éléments (fond, couche de liant et joints de dilatation) qui constituent un véritable système sol. Seules des opérations de pose correctes garantissent un résultat final parfait.

De préférence, la pose doit être effectuée par des adhésifs appropriés, et il est conseillé de se conformer aux instructions du fabricant.

Dans les endroits très fréquentés ou soumis au passage de charges lourdes, il est recommandé d'utiliser le système à la double diffusion.

Les matériaux Ariostea imitent le hasard de la nature et ses variations de

couleurs, caractéristiques que l'habileté du carreleur peut exalter.

Afin de rehausser au mieux les caractéristiques du matériau, il est conseillé de suivre, lors de la pose, les indications suivantes:

- Etaler quelques carreaux sur le sol (au moins 3 m²) pour contrôler l'effet d'ensemble. Prélever la matériau de plusieurs boîtes.
- Ne pas immerger la matériau dans l'eau avant la pose.
- Pour la coupe des carreaux, et notamment des surfaces polies, ne pas écrire au crayon ou au feutre sur la face visible.
- Attendre de 48 à 72 heures avant de marcher sur le sol.

SMANTELLAMENTO DEL PAVIMENTO / FLOORING REMOVAL / ABBRUCH DES BODENBELAGS / DÉPOSE DE PLANCHER

SMANTELLAMENTO DEL PAVIMENTO La selezione dei materiali da costruzione in funzione della loro durabilità è un elemento fondamentale per la sostenibilità ambientale di un edificio. Infatti un materiale con un ciclo di vita più lungo, con la stessa funzione d'uso di un altro, determina un impatto ambientale minore. I materiali Ariostea, se correttamente installati, possono durare quanto

l'edificio in cui sono stati collocati. Inoltre, alla fine del ciclo di vita, i residui derivanti dalla loro demolizione non richiedono trattamenti poiché, in virtù dell'elevata inerzia chimica, non rilasciano sostanze nell'ambiente.

Il rifiuto generato dovrà essere recuperato o smaltito, nel rispetto delle normative nazionali e locali vigenti.

FLOORING REMOVAL The selection of construction materials on the basis of their durability is fundamental to create an environmentally sustainable building. A material with the same function as another one but a longer life cycle has a lesser environmental impact. When properly installed, Ariostea materials last as long as the building they are placed in. Moreover, at the end of their life

cycle, the demolition waste does not require treatment since it does not release any substances into the environment, thanks to its high chemical inertia. The waste generated must be salvaged or disposed of in accordance with the state and local regulations in force.

ABBRUCH DES BODENBELAGS Die Auswahl der Baumaterialien nach ihrer Lebensdauer ist ein grundlegender Faktor für die Umweltverträglichkeit eines Gebäudes. In der Tat hat ein Material mit einem längeren Lebenszyklus und dem selben Verwendungszweck eines anderen geringere Umweltauswirkungen. Die Ariostea Materialien können, wenn sie richtig verlegt werden, so lange halten, wie das Gebäude, in dem sie sich befinden. Am Ende des Lebenszyklus

dieser Produkte verlangen die beim Abbruch entstehenden Reste zudem keine Aufbereitung, da sie aufgrund ihrer hohen chemischen Inertheit keine Substanzen in die Umwelt abgeben. Die entstehende Abfälle müssen unter Beachtung der nationalen und örtlichen Bestimmungen rückgewonnen oder entsorgt werden.

DÉPOSE DE PLANCHER Sélectionner les matériaux de construction en fonction de leur durabilité est fondamental pour déterminer la compatibilité écologique d'un bâtiment. En effet, un matériau avec un cycle de vie plus long et la même fonction qu'un autre, a un impact moindre sur l'environnement. Les matériaux Ariostea, s'ils sont correctement installés, peuvent durer aussi longtemps que le bâtiment où ils ont été posés. En outre, à la fin du cycle de

vie de ces produits, les résidus de démolition ne requièrent pas de traitements; en effet leur inertie chimique étant élevée, aucune substance n'est libérée dans l'environnement. Le déchet produit devra être récupéré ou éliminé, conformément aux réglementations nationales et locales en vigueur.

STUCCATURA E PULIZIA FINALE /JOINTING AND FINAL CLEANING / VERFUGUNG UND ENDREINIGUNG / JOINTOIEMENT ET NETTOYAGE FINAL

STUCCATURA E PULIZIA FINALE Con collanti a presa normale, stuccare il pavimento dopo 24/48 ore, se si utilizzano adesivi rapidi dopo 4h.

- Soprattutto sui materiali levigati lucidati utilizzare stucchi cementizi con colori tono su tono, evitando su materiali chiari, stucchi di colore scuro e viceversa. Per la stuccatura di queste superfici non adoperare stucchi epossidici o malte flessibili a base di materiali sintetici (Flexfughe) soprattutto se a contrasto col colore del materiale e non aggiungere additivi/lattici allo stucco. Essi infatti rendono estremamente difficoltosa l'eliminazione dei residui con i normali prodotti di pulizia. Se si decide comunque di utilizzare questa tipologia di stucco, testarli sempre prima sul materiale.
- Stendere lo stucco con spatola gommatata su tutta la superficie del materiale.
- Stuccare piccole superfici per volta, asportando le quantità eccedenti con spugne o stracci umidi (di sola acqua pulita) o utilizzare apposite macchine per togliere lo stucco eccedente, quando ancora il velo di stucco è umido.

- Un'adeguata pulizia iniziale è fondamentale sia per valorizzare la brillantezza, sia per assicurare la pulibilità e la semplicità di manutenzione ordinaria. La pulizia iniziale va quindi effettuata immediatamente dopo la posa, utilizzando prodotti a base acida, strofinando energicamente e sciacquando abbondantemente con acqua. In questo modo sarà possibile eliminare i residui di stucco, collante, cemento, ecc. E' possibile utilizzare tutti i detergenti disponibili sul mercato, con unica esclusione dei prodotti contenenti acido fluoridrico (composti e derivati) come previsto dalla norma EN 14411.
- Si raccomanda una accurata protezione del pavimento posato. Qualora sia necessario eseguire altre operazioni quali tinteggiatura, lavori idraulici o qualsiasi altro lavoro, si consiglia, terminata la posa, di coprire il pavimento con teli PVC o AIRBALLS o tessuti.

JOINTING AND FINAL CLEANING When the floor has been laid using normal setting adhesives, joint the tiles after 24/48 hours, in the case of quick setting adhesives, after 4 hours.

- Especially with honed and polished materials, use cement-based grout with tone on tone colours (if possible avoid dark coloured grouts like black,blue, red with light coloured materials and vice-versa). For jointing these surfaces, do not use epoxy grouts or flexible mortar with a synthetic base (Flexfughe) especially if the colour contrasts with the material and do not add additives/ latex to the grout. These products in fact make it extremely difficult to eliminate the residues with normal cleaning products. Should this kind of grout be used anyway, take care of testing it on the material beforehand.
- Spread the grout with a rubber spatula all over the material surface.
- Joint small areas at a time, removing the excess with damp sponges or rags (using only clean water) or with special machines for removing the excess grout

- while this is still damp.
- Proper initial cleaning is fundamental both for enhancing its aesthetic and shine characteristics and for restoring its original characteristics of easy cleaning and ease of ordinary maintenance. It is therefore very important that initial cleaning is carried out immediately after installation, rubbing hard with acid-based products, followed by abundant rinsing with water. In this way it will be possible to eliminate the residues of grout, adhesive, cement, etc. It is possible to use any of the detergents available on the market, with the exclusion only of products containing hydrofluoric acids (composites and derivatives) according to EN standard 14411.
- The floor must be carefully protected. Should it be necessary to carry out other operations such as decorating, plumbing or any other kind of work, once the floor has been installed it is advisable to cover it with PVC or AIRBALLS sheets or cloths.

VERFUGUNG UND ENDREINIGUNG Bei der Verlegung mit normal härtenden Klebern, den Boden nach 24 / 48 Stunden, bei der Verwendung von Schnellklebern bereits nach 4 Stunden verfugen.

- Insbesondere auf den glanzpolierten Materialien sollten Zementkitt in ähnlichen Farbtönen verwendet werden (es sollte vermieden werden, auf hellen Materialien dunkle, beispielsweise schwarze, blaue oder rote Kitt zu verwenden; dasselbe gilt für helle Kitt auf dunklen Fliesen).

- Für das Verfugen dieser Oberflächen auf keinen Fall kunsthartgebundenen Fugenmörtel oder bewegliche Mörtel auf Basis von synthetischen Materialien (z.B. Flexfughe) verwenden, vor allem nicht in Kontrastfarbe zur Fliese. Außerdem dürfen dem Kitt keine Zusatzstoffe oder Latex zugeschlagen werden, da durch diese Zuschläge die Entfernung der Restrückstände mit den normalen Reinigungsmitteln extrem erschwert wird. Sollen Sie sich dennoch für einen kunsthartgebundenen Fugenmörtel entscheiden, testen Sie diesen vorher auf dem Material.

- Den Kitt mit einer Gummispachtel auf der gesamten Materialoberfläche gleichmäßig auftragen.

- Die kleinen Oberflächen einzeln verfugen und die entsprechenden Restrückstände mit einem feuchten Schwamm oder Lappen (der nur in reines Wasser getaucht wurde) entfernen, oder spezielle Maschinen für das Entfernen

von Restrückständen verwenden, wobei der Kitt noch feucht sein muß.

- Eine korrekte anfängliche Reinigung ist besonders wichtig, weil somit sowohl die ästhetischen Besonderheiten und der Glanz des Materials hervorgehoben werden, und zudem die zukünftigen und lang anhaltenden Eigenschaften der einfachen Reinigung und der praktischen regelmäßigen Pflege dieses Materials zur Geltung kommen können.

Es ist deshalb sehr wichtig, daß die erste Reinigung mit säurehaltigen Reinigungsmitteln sofort nach der Verlegung des Materials erfolgt, wobei die Fliesen fest zu reiben und dann gründlich mit frischem Wasser zu spülen sind. Auf diese Weise können alle Restrückstände von Kitt, Kleber, Zement usw. gründlich entfernt werden. Zu diesem Zweck können alle erhältlichen Reinigungsmittel verwendet werden, mit Ausnahme aller Produktartikel, die Fluorwasserstoffsäure (Verbindungen und Derivate) enthalten, laut der Vorschrift EN 14411.

- Es wird empfohlen, den verlegten Boden sorgfältig zu schützen. Sollten andere Arbeiten, wie zum Beispiel das Färben, das Verlegen von Heizungs- und Wasserleitungen oder ähnliches erforderlich sein, empfehlen wir den Boden nach dem Verlegen mit Planen aus PVC, AIRBALLS oder Gewebbahnen abzudecken.

JOINTOIEMENT ET NETTOYAGE FINAL En cas de pose avec des adhésifs à prise normale, jointoyer le sol après 24/48 heures; si l'on utilise des adhésifs à prise rapide, après 4h.

- Sur les matériaux polis lustrés surtout, utiliser des mortiers-joints avec des couleurs ton sur ton (éviter si possible sur des matériaux de couleur claire des mortiers de couleur foncée comme le noir, le bleu, le rouge et vice-versa).

Pour le jointoiment de ces surfaces, ne pas utiliser Mastics époxydes ou de mortiers flexibles à base de matériaux synthétiques (Flexfughe) surtout s'il y a contraste avec la couleur du matériau, et ne pas ajouter d'additifs/lactiques au mastic. En effet, ces derniers rendent l'élimination des résidus extrêmement difficile avec les nettoyeurs normaux. Si de toute façon on décide de continuer à utiliser ce type de mortier il faudra toujours le tester avant.

- Etaler le mortier à la spatule caoutchoutée sur toute la surface du matériau.

- Jointoyer de petites surfaces à la fois en enlevant les quantités en excès avec une éponge ou des chiffons humidifiés (exclusivement d'eau propre) ou utiliser des machines spéciales pour enlever le mortier en excès quand le voile de

mortier est encore humide.

- Un nettoyage initial adapté est d'une importance fondamentale aussi bien pour mettre en valeur les caractéristiques esthétiques et de brillance, que pour rétablir les caractéristiques de facilité de nettoyage et d'entretien ordinaire. C'est la raison pour laquelle il est fondamental que le nettoyage initial soit effectué immédiatement après la pose, en utilisant des produits à base acide, en frottant énergiquement et, par la suite, en frottant abondamment avec de l'eau. Il sera ainsi possible d'éliminer les résidus de mortier, d'adhésif, de ciment, etc. Il est possible d'utiliser tous les nettoyeurs disponibles sur le marché, à l'exception des produits contenant de l'acide fluorhydrique (composés et dérivés) comme le prévoit la norme EN 14411.

- Il est recommandé de protéger soigneusement le sol posé. S'il s'avère nécessaire d'exécuter d'autres opérations comme la peinture, les travaux de plomberie ou autre, une fois la pose terminée, nous conseillons de couvrir le sol avec des bâches en PVC ou AIRBALLS ou avec du tissu.

MANUTENZIONE E CURA / MAINTENANCE AND CARE / WARTUNG UND PFLEGE / ENTRETIEN ET SOIN

MANUTENZIONE E CURA Grazie al procedimento produttivo impiegato (alte temperature di cottura, materie prime di qualità e processo di sinterizzazione) la superficie dei materiali Ariostea è praticamente impermeabile (assorbimento d'acqua minimo). Per la manutenzione ordinaria si consiglia di utilizzare detergenti neutri privi di cere o prodotti ceranti onde evitare la formazione di strati untuosi, alternando se necessario saltuari lavaggi con detergenti alcalini in

concentrazione blanda ben sciacquati al termine.

Al fine di preservare le superfici dallo sporco e dalle lavorazioni di cantiere, a posa terminata le pavimentazioni, in particolar modo quelle realizzate con materiali levigati, devono essere adeguatamente protette con truciolare o altri materiali idonei. In tal modo sarà possibile evitare danneggiamenti provocati da lavorazioni successive.

MAINTENANCE AND CARE Thanks to the characteristics of the production process (high firing temperature, raw materials of great quality, sinterizing process), the surface of Ariostea material is waterproof (the water absorption is minimum). For standard maintenance we recommend to use neutral waxless detergents in order to avoid greasy films and to alternate, if necessary, with some occasional washings made with alkaline products in weak concentration

and abundantly rinsed at the end.

After the installation of floors, particularly of those made with polished materials, the surfaces should be adequately protected with particle board or other suitable materials in order to protect them from dirt and on-site processing. This prevents damage caused by subsequent processing.

WARTUNG UND PFLEGE Dank des angewandten Produktionsverfahrens (hohe Brenn-temperatur, qualitativ hochwertiges Rohmaterial und Sinterung) ist die Oberfläche der Ariosteal Materialien praktisch völlig wasserabweisend (minimale Feuchtigkeitsaufnahme).

Für die tägliche Unterhaltung empfehlen wir die Verwendung von neutralem Reiniger. Es ist davon abzuraten, wachshaltige Reinigungsmittel oder Produkte zum Einwachsen zu verwenden, um die Bildung von öligen Schichten zu vermeiden. Hin und wieder kann man bei Bedarf eine Reinigung mit einem in

Wasser verdünnten alkalischen Mittel durchführen, welcher nachträglich mit klarem Wasser sorgfältig abgewaschen werden soll.

Um die Oberflächen vor Verschmutzungen und Beschädigungen durch Bauarbeiten zu schützen, müssen die Bodenbeläge, insbesondere die aus geschliffenen Materialien, nach der Verlegung entsprechend mit Spanplatten oder anderen geeigneten Materialien abgedeckt werden. Auf diese Weise können Beschädigungen durch spätere Arbeiten vermieden werden.

ENTRETIEN ET SOIN Grâce aux caractéristiques du procédé de production (hautes températures de cuisson, matières premières de qualité et procédé de grésage) la surface des matériaux Ariosteal est pratiquement imperméable (l'absorption d'eau est minimum). Pour l'entretien quotidien, nous conseillons d'utiliser des détergents neutres, sans cire ou produits de cirage, afin d'éviter la formation de couches de graisse. Si nécessaire, alterné des lavages occasionnel

avec des détergents alcalins abondamment dilués et bien rincés à la fin.

Après avoir achevé la pose des sols, notamment ceux réalisés avec des matériaux polis, il faut protéger comme il se doit, les surfaces contre la saleté et résidus de chantier, en appliquant des panneaux de particules ou autre matériaux similaires. Il sera ainsi possible d'éviter que les opérations suivantes n'abîment le carrelage.

PAVIMENTI SOPRAELEVATI / RISED FLOORS / DOPPELBÖDEN / PLANCHERS SURÉLEVÉS

PAVIMENTI SOPRAELEVATI Il pavimento sopraelevato è un sistema di pavimentazione concepito per rispondere alle diverse esigenze degli ambienti di lavoro ad alta concentrazione di impiantistica, che permette il passaggio di cablaggi e connessioni di ogni genere o che può essere utilizzato per il passaggio dell'aria. Questo sistema permette rapidi ed efficaci interventi di manutenzione e modifica di cablaggi e connessioni, grazie alla possibilità di smontare a secco le lastre, senza la necessità di modifica delle opere murarie, limitando in questo modo tempi e costi degli interventi.

Rispetto ai pavimenti tradizionali, tali sistemi polifunzionali sono una perfetta sintesi tra praticità progettuale, coerenza architettonica e funzionalità, durata nel tempo, razionalità e tecnologia ambientale: per tutti questi motivi i pavimenti sopraelevati sono il sistema edilizio oggi più impiegato in uffici, show-room, concessionarie e in tutti gli spazi ad attività produttive.

Il materiale ARIOSTEA si sposa perfettamente con questo sistema, in quanto associa soluzioni estetiche pregiate a caratteristiche fisico-meccaniche di eccellenza, offrendo lastre con diversi formati e finiture fra loro assemblabili,

per consentire la massima flessibilità progettuale.

Inoltre, grazie all'ampia varietà dei materiali Ariosteal e alla tecnica del taglio computerizzato ad idrogetto, l'ufficio tecnico Ariosteal è in grado di fornire una valida assistenza per la progettazione di pavimentazioni personalizzate.

Pavimento sopraelevato per esterno Novità nel campo edilizio, il pavimento sopraelevato per esterno viene concepito per applicare la completa flessibilità del sistema anche nella pavimentazione di zone esterne, solitamente risolte con soluzioni tradizionali, permettendo l'ispezione degli elementi sottostanti al nuovo piano di calpestio (ad es. tubazioni con funzione di scolo per l'acqua piovana, pozzetti e griglie).

Composto da due semplici elementi, quali supporti portanti prefabbricati in polipropilene e lastre di finitura, il pavimento sopraelevato per esterno contribuisce ad eliminare risalite di umidità, problemi di gelate e infiltrazioni d'acqua, e permette il passaggio di impianti e tubazioni.

RAISED FLOORS A raised floor is a flooring system designed to meet the different requirements of working areas with a high concentration of mechanical systems. The system permits cabling and connections of all kinds to be passed through it or it can be used for ventilation.

This system permits rapid and effective maintenance and changes to cabling and connections because the slabs can be removed dry with no need for masonry work, thus reducing time and cost. Compared to traditional flooring, such poly-functional systems are a perfect combination of practicality of design, architectural coherence and functionality, durability, rationality and environmentally-friendly technology: for all these reasons, raised flooring is nowadays the building system most commonly used in offices, show rooms, dealerships and in all production areas.

ARIOSTEA is a material that works well with this system because it combines fine aesthetic solutions with excellent physical-mechanic characteristics, offering panels in various sizes and finishes that can be assembled together,

enabling maximum design flexibility.

Moreover, thanks to the ample choice of Ariosteal and computerised hydrojet cutting, Ariosteal's technical department is able to provide support for the design of customised flooring.

Raised floors for exteriors A very recent addition in the building field, raised flooring for exteriors brings all the system's flexibility to paving outdoor areas as well, where traditional solutions are normally used; it allows for the inspection of elements underneath the new treadable surface such as rainwater drain pipes, inspection holes and grills).

The solution combines two simple elements: pre-fabricated, polypropylene load-bearing supports and finishing slabs. Raised flooring for exteriors can help to eliminate problems of rising damp, frost and water infiltration and allows for the passage of systems and pipes.

DOPPELBÖDEN Der Doppelboden ist ein Bodensystem für die verschiedenen Anforderungen in Arbeitsumgebungen mit einer hohen Anlagendichte. Er ermöglicht das Verlegen von Verkabelungen und Verbindungen aller Art und kann auch zur Luftleitung benutzt werden.

Dieses System ermöglicht rasche und effiziente Wartungs- und Änderungsarbeiten an Verkabelungen und Verbindungen, da die Platten ohne Notwendigkeit von Änderungen am Mauerwerk trocken abmontiert werden können. Auf diese Weise kann bei den Arbeiten Zeit und Geld gespart werden. Im Vergleich zu herkömmlichen Böden sind diese Multifunktionssysteme eine perfekte Synthese aus praktischer Planung, architektonischer Kohärenz und Funktionalität, langer Haltbarkeit, Rationalität und Umwelttechnologie: Aus all diesen Gründen sind Hochböden heute das meistangewandte Bausystem in Büros, Ausstellungsräumen, bei Vertragshändlern und in allen Räumen für Produktionstätigkeiten. Das Material von ARIOSTEA - verschmilzt perfekt mit diesem System, da es hochwertige ästhetische Lösungen mit hervorragenden physikalischen und mechanischen Eigenschaften verbindet. Es bietet Platten in verschiedenen Formaten und Ausführungen, die untereinander zusammengebaut werden können, um so die größtmögliche Flexibilität bei der

Planung zu ermöglichen.

Außerdem ist das technische Büro von Ariostea dank der großen Vielfalt der Materialien von Ariostea und der computergesteuerten Schneidetechnik mit Wasserstrahl imstande, Sie bei der Planung von individuell gestalteten Böden zu unterstützen.

Doppelboden für den Außenbereich Eine Neuheit auf dem Gebiet des Baus ist der Doppelboden für den Außenbereich. Er wurde entwickelt, um die komplette Flexibilität des Systems auch bei Böden im Außenbereich anwenden zu können, wo bislang üblicherweise herkömmliche Lösungen verwendet wurden. Mit ihm kann man Elemente inspizieren, die unterhalb der neuen begehbaren Ebene liegen (z.B. Rohrleitungen für den Abfluss von Regenwasser, Schächte und Gitter).

Er besteht aus zwei einfachen Elementen, nämlich vorgefertigten tragenden Teilen aus Polypropylen und oberflächenbehandelten Platten. Der Doppelboden für den Außenbereich trägt dazu bei, das Aufsteigen von Feuchtigkeit, Vereisungsprobleme und Einsickern von Wasser auszumerzen und ermöglicht die Verlegung von Anlagen und Rohrleitungen.

PLANCHERS SURÉLEVÉS Le plancher surélevé est un système de sol conçu pour répondre aux diverses exigences des espaces de travail à haute concentration d'installations techniques, permettant le passage de câblages et de connexions de toutes sortes et pouvant aussi être utilisé pour le passage de l'air.

Grâce à la possibilité de démonter les panneaux à sec sans avoir besoin d'intervenir sur les travaux de maçonnerie, ce système permet d'effectuer rapidement et efficacement des interventions d'entretien et de modification des câblages et des connexions, limitant ainsi les délais et les coûts d'intervention.

Comparés aux planchers traditionnels, ces systèmes polyfonctionnels sont une synthèse parfaite entre la commodité de conception, la cohérence architecturale et la fonctionnalité, la longévité, la rationalité et la technologie ambiante : pour toutes ces raisons, les planchers surélevés sont le système le plus utilisé aujourd'hui dans le bâtiment pour les bureaux, les showrooms, les concessionnaires et pour tous les espaces à activités productives.

En associant des solutions esthétiques de qualité à des caractéristiques physico-mécaniques d'excellence, le matériel ARIOSTEA s'adapte parfaitement à ce système, en offrant des panneaux de divers formats et finitions pouvant

s'assembler entre eux pour consentir la plus grande flexibilité conceptuelle possible.

Par ailleurs, grâce à la grande variété des matériels Ariostea et à la technique de la découpe informatisée à hydrogène, le service Ariostea peut fournir une assistance de qualité pour la projection de planchers personnalisés.

Plancher surélevé pour extérieur Nouveauté dans le domaine du bâtiment, le plancher surélevé pour extérieur est également conçu pour appliquer la flexibilité totale du système au sol des zones externes, habituellement résolues par des solutions traditionnelles, en permettant l'inspection des éléments situés au-dessous du nouveau plan de piétinement (par ex. conduits d'écoulement de l'eau de pluie, puits et grilles).

Composé de deux simples éléments, des supports portants préfabriqués en polypropylène et des panneaux de finition, le plancher surélevé pour extérieur contribue à éliminer les remontées d'humidité, les problèmes de gel et d'infiltrations d'eau et permet le passage des installations techniques et des conduites.

PARETI VENTILATE / VENTILATED FAÇADES / HINTERLÜFTETE FASSADEN / FAÇADES VENTILÉES

PARETI VENTILATE I rivestimenti esterni degli edifici ricoprono un ruolo di primaria importanza nell'architettura contemporanea e nella qualificazione del paesaggio urbano, oltre a svolgere un'importante funzione di protezione degli agenti atmosferici. Essi garantiscono una notevole valorizzazione estetico-prestazionale dell'edificio, nettamente superiore alla muratura tradizionale.

Il rivestimento esterno montato in facciata ventilata crea un'intercapedine d'aria che "allontana" dalla parete muraria sia gli agenti atmosferici che il calore creato dalle radiazioni solari, producendo un'efficienza termica ed un conseguente risparmio energetico ed economico sia nella stagione calda che in quella fredda, ovvero riduce nel periodo estivo il carico di calore sull'edificio, e viceversa trattiene all'interno il calore nella stagione invernale.

Ai vantaggi principali si aggiungono la dispersione del vapore acqueo, il miglioramento dell'isolamento acustico e la riduzione degli interventi manutentivi. Il materiale tecnico a massa compatta di ARIOSTEA, grazie alle proprie caratteristiche (elevata resistenza meccanica, agli sbalzi termici, inalterabilità dei colori alla luce, assorbimento d'acqua pressoché nullo, ingelività e leggerezza delle lastre) è da ritenersi particolarmente idoneo per l'utilizzo in facciata ventilata, sia con aggancio visibile, che a scomparsa (non visibile).

Inoltre i materiali Ariostea consentono con la loro ricchezza di cromie e superfici, un'ampia flessibilità progettuale, garantendo risultati estetici di alto livello e prestazioni elevate in termini di durata nel tempo, facilità di posa e ridotta manutenzione.

VENTILATED FAÇADES External facing on buildings plays a crucial role in contemporary architecture and the development of the urban landscape. It also has the important function of providing protection from atmospheric agents and it significantly improves the building's aesthetic and performance aspects, which are markedly superior to traditional walls. The external facing mounted on the ventilated façade creates an air space that "protects" the wall from atmospheric agents and from solar radiation heat producing thermal efficiency and providing subsequent energy and financial savings both in warm and cool seasons. In the summer, it reduces the heat load on the building and does the opposite in the winter by keeping the heat inside the building.

An additional advantage is the dispersion of water vapour, which improves insulation and reduces the need for maintenance.

ARIOSTEA blocks are considered to be especially suited for use in ventilated façades (good mechanical resistance, resistant to temperature changes, the colours do not fade, it absorbs almost no water, it does not freeze and the blocks are lightweight), and come with both visible and hidden (invisible) hooks. Moreover Ariostea materials allow, thanks to their varied array of colours and surfaces, wide design flexibility that guarantees high-level aesthetic results and high performance in terms of duration in time, as well as easy installation and reduced maintenance.

HINTERLÜFTETE FASSADEN Die Außenverkleidungen der Gebäude spielen eine außerordentlich wichtige Rolle in der modernen Architektur und der Gestaltung des städtischen Landschaftsbildes. Außerdem üben sie eine bedeutende Schutzfunktion gegen Witterungseinflüsse aus. Sie garantieren eine beachtliche Ästhetik- und Leistungsaufwertung des Gebäudes, die weit über der von einem traditionellen Mauerwerk gewährleistet liegt. Die Außenverkleidung, die durch eine hinterlüftete Fassade realisiert wird, bildet einen Luftzwischenraum, der das Mauerwerk vor Witterungseinflüssen sowie vor der von den Sonneneinstrahlungen verursachten Wärme „schützt“. Er erzeugt eine thermische Effizienz und hat somit eine höhere Energie- und Kosteneinsparung sowohl in der warmen, als auch in der kalten Jahreszeit zur Folge, d.h. er vermindert in der Sommerzeit die Wärmebelastung für das Gebäude und bewahrt in der Winterzeit die Wärme im Gebäudeinnern. Weitere Eigenschaften, die sich den vorrangigen Vorteilen hinzufügen, sind

FAÇADES VENTILEES Les revêtements externes des bâtiments jouent un rôle primordial dans l'architecture contemporaine et dans la qualification du paysage urbain. Ils ont également une fonction importante de protection contre les agents atmosphériques. Ils garantissent une valorisation importante, nettement supérieure à une maçonnerie traditionnelle, tant du point de vue esthétique que des prestations du bâtiment. Le bardage externe monté sur la façade ventilée crée un matelas d'air qui éloigne du mur aussi bien les agents atmosphériques que la chaleur générée par les rayons solaires. Il provoque donc une action thermique efficace, en engendrant un gain énergétique et économique tant pendant la saison chaude que pendant la saison froide. En effet, ce système réduit la charge de chaleur qui frappe le bâtiment pendant l'été et, vice-versa, il garde la chaleur à l'intérieur pendant l'hiver.













die Wasserdampfdiffusion, die Verbesserung der Schalldämmung und die Reduzierung von Wartungs- und Instandhaltungsarbeiten. Das technische kompakte Material von ARIOSTEA erweist sich, dank seiner Eigenschaften (hohe mechanische Festigkeit, Temperaturwechselbeständigkeit, Lichtbeständigkeit der Farben, ausgesprochen geringe Wasseraufnahme, Frostbeständigkeit und das geringe Gewicht der Platten) als besonders geeignet für die Verwendung bei hinterlüfteten Fassaden, sowohl mit sichtbarer Befestigung, als auch mit verdeckter Befestigung (nicht sichtbar). Zudem ermöglichen die Materialien von Ariostea mit ihrer Vielfalt an Farben und Oberflächenausführungen beträchtliche Gestaltungsmöglichkeiten und gewährleisten dabei ästhetische Ergebnisse von hohem Niveau und sehr hoher Leistungsfähigkeit, was Lebensdauer, einfache Verlegung und Pflegeleichtigkeit betrifft.

Il faut aussi ajouter l'élimination de la condensation, l'amélioration de l'isolation acoustique et la réduction des interventions d'entretien aux avantages essentiels susmentionnés. Le matériau technique à masse compacte ARIOSTEA est particulièrement approprié pour l'utilisation sur des façades ventilées, comme couche d'accrochage visible ou invisible, de par ses caractéristiques (résistance mécanique élevée aux sautes de température, inaltérabilité des couleurs aux rayons UV, absorption de l'eau quasiment nulle, matériau non gélif, légèreté des plaques). De plus, les matériaux Ariostea confèrent, grâce au large éventail de coloris et de surfaces, une grande flexibilité aux projets, en garantissant des résultats esthétiques de haut niveau et des prestations élevées en termes de durée dans le temps, de facilité de pose et d'entretien réduit au minimum.

INFORMAZIONI E CODICI /
INFORMATION AND CODES /
INFORMATIONEN UND ARTIKELNR. /
CODES ET INFORMATIONS

**CARATTERISTICHE TECNICHE / TECHNICAL FEATURES /
TECHNISCHE EIGENSCHAFTEN / CARACTÉRISTIQUES TECHNIQUES**

CLASSIFICAZIONE SECONDO LE NORME CEN E ISO GRUPPO B1a-UGL EN 14411 ALL.G E ISO 13006 ALL.G / CLASSIFICATION IN ACCORDANCE WITH CEN AND ISO STANDARDS B1a-UGL EN 14411 ENCLOSED G AND ISO 13006 ENCL. G / KLASSIFIZIERUNG GEMÄß CEN UND ISO NORMEN GRUPPE B1a-UGL EN 14411 ANL. G UND ISO 13006 ANL.G / CLASSIFICATION SELON LES NORMES CEN ET ISO GROUPE B1a-UGL EN 14411 P.J.G ET ISO 13006 P.J.G

PROPRIETÀ CHIMICO - FISICHE / CHEMICAL / PHYSICAL PROPERTIES / CHEMISCH PHYSISCHE EIGENSCHAFTEN / PROPRIÉTÉS CHIMICO - PHYSIQUES	NORMA / REGULATION / NORMEN / NORME	VALORE PRESCRITTO / REQUIRED VALUE / VORGESCHRIEBENER WERT / VALUER PRESCRITE	VALORI MEDI ARIOSTEA / ARIOSTEA AVERAGE VALUES / ARIOSTEA DURCHSCHNITTSWERTE / VALEURS MOYENNES ARIOSTEA
 ASSORBIMENTO D'ACQUA WATER ABSORPTION / WASSERAUFNAHME / ABSORPTION D'EAU	ISO 10545-3	≤ 0,5 %	0,02% - 0,04% SÚPERFICI NATURALI, STRUTTURATE E PRELEVIGATE/ NATURAL, STRUCTURED AND PREPOLISHED SURFACES/ NATURBELASSENE, STRUKTURIERTE UND VORGESCHLIFFENE OBERFLÄCHEN/ SURFACES NATURELLES, STRUCTURÉES ET PREPOLIES 0,05% - 0,07% SÚPERFICI LEVIGATE/ POLISHED SURFACES/ POLIERTE OBERFLÄCHEN/ SURFACES POLIES
 DIMENSIONI SIZES / ABMESSUNGEN / DIMENSIONS	ISO 10545-2	± 0,6% max LUNGHEZZA E LARGHEZZA / LENGHT AND WIDTH / LÄNGE UND BREITE / LONGUEUR ET LARGEUR ± 5% max SPESSORE / THICKNESS / STÄRKE / EPAISSEUR ± 0,5% max RETTILINEITÀ* SPIGOLI / LINEARITY / KANTENGERADHEIT / RECTITUDE DES ARÊTES ± 0,6% max ORTOGONALITÀ* / WEDGING / RECHTWINKLIGKEIT / ORTHOGONALITÉ ± 0,5% max PLANARITÀ* / WARPAGE / EBENFLÄCHIGKEIT / PLANÉITÉ	± 0,1%* LUNGHEZZA E LARGHEZZA / LENGHT AND WIDTH / LÄNGE UND BREITE / LONGUEUR ET LARGEUR ± 5% SPESSORE / THICKNESS / STÄRKE / EPAISSEUR ± 0,1%* RETTILINEITÀ* SPIGOLI / LINEARITY / KANTENGERADHEIT / RECTITUDE DES ARÊTES ± 0,1%* ORTOGONALITÀ* / WEDGING / RECHTWINKLIGKEIT / ORTHOGONALITÉ ± 0,2% PLANARITÀ* / WARPAGE / EBENFLÄCHIGKEIT / PLANÉITÉ
 ASPETTO / APPEARANCE / AUSSEHEN / ASPECT		95% MIN. ESENTE DA DIFETTI / MIN. 95% DEFECT FREE / MINDESTENS ZU 95% FEHLERFREI / 95% MIN. SANS DÉFAUTS	CONFORME / CONFORMS / KONFORM / CONFORME
 RESISTENZA ALL'ABRASIONE PROFONDA / DEEP ABRASION RESISTANCE / TIEFVERSCHLEISSBESTÄNDIGKEIT / RESISTANCE A L'ABRASION PROFONDE	ISO 10545-6	max 175 mm ³	145 mm ³
 RESISTENZA AI PRODOTTI CHIMICI RESISTANCE TO CHEMICAL PRODUCTS / CHEMIKALIENBESTÄNDIGKEIT / RESISTANCE AUX PRODUITS CHIMIQUES	ISO 10545-13	UBmin	CONFORME / CONFORMS / KONFORM / CONFORME
 RESISTENZA ALLE MACCHIE STAIN RESISTANCE / FLECKENBESTÄNDIGKEIT / RESISTANCE AUX TACHES	ISO 10545-14	METODO DI PROVA DISPONIBILE / TESTING METHOD AVAILABLE/ VERFÜGBARES PRÜFVERFAHREN / MÉTHODE D'ESSAI DISPONIBILE	CLASSE 5 / CLASS 5 / ** KLASSE 5 / CLASSE 5
 MODULO DI ROTTURA (R) MODULS OF RUPTURE (R) / BRUCHMODUL (R) / MODULE DE RUPTURE (R)	ISO 10545-4	≥ 35 N/mm ²	48 N/mm ²
 SFORZO DI ROTTURA (S) BREAKING STRENGTH (S) / BRUCHKRAFT (S) / FORCE DE RUPTURE (S)		SPESSORE/ THICKNESS/ STÄRKE/ EPAISSEUR: a) ≥ 7,5mm = ≥ 1300 N b) < 7,5mm = ≥ 700 N	SPESSORE/ THICKNESS/ STÄRKE/ EPAISSEUR: a) 2500 N *** b) CONFORME/ CONFORMS/ KONFORM/ CONFORME
 RESISTENZA SBALZI TERMICI RESISTANCE TO THERMAL SHOCKS / TEMPERATURWECHSELBESTÄNDIGKEIT / RESISTANCE AUX ECARTS DE TEMPERATURE	ISO 10545-9	METODO DI PROVA DISPONIBILE / TESTING METHOD AVAILABLE/ VERFÜGBARES PRÜFVERFAHREN / MÉTHODE D'ESSAI DISPONIBILE	RESISTENTE / RESISTANT / BESTÄNDIG / RESISTANT
 RESISTENZA COLORI ALLA LUCE RESISTANCE TO LIGHT/ LICHTBESTÄNDIGKEIT DER FARBEN/ RESISTANCE DES COULEURS A LA LUMIERE	DIN 51094		SUP. INALTERATA / UNAFFECTED SURFACE / OBERFLÄCHE UNVERÄNDERT / SURFACE INALTEREE
 DILATAZIONE TERMICA LINEARE COEFFICIENT OF LINEAR THERMAL EXPANSION / LINEARER WÄRMEAUSSDEHNUNGSKOEFFIZIENT / DILATATION THERMIQUE LINEAIRE	ISO 10545-8	METODO DI PROVA DISPONIBILE / TESTING METHOD AVAILABLE/ VERFÜGBARES PRÜFVERFAHREN / MÉTHODE D'ESSAI DISPONIBILE	6,2x10 ⁻⁶ °C ⁻¹
 RESISTENZA AL GELO / FROST RESISTANCE / FROSTBESTÄNDIGKEIT / RESISTANCE AU GEL	ISO 10545-12	RICHIESTI 100 CICLI DI GELO-DISGELO / REQUESTED 100 FREEZE-THAW CYCLES / 100 GEFRIER-AUFTAUZYKLEN ANGEFRAGT / DEMANDÉE 100 CYCLES DE GEL-DÉGEL	RESISTENTE / RESISTANT / BESTÄNDIG / RESISTANT
 COEFFICIENTE DI ATTRITO / FRICTION COEFFICIENT / REIBUNGSKOEFFIZIENT / COEFFICIENT DE FRICTION	BCR DIN 51130/51097	μ ≥ 0,40 ATTRITO SODDISFACENTE/ SATISFACTORY FRICTION/ BEFRIEDIGENDE REIBUNG/ FRICTION SATISFAISANTE	CONFORME/ CONFORMS/ KONFORM/ CONFORME SÚPERFICI NATURALI, STRUTTURATE E PRELEVIGATE/ NATURAL, STRUCTURED AND PREPOLISHED SURFACES/ NATURBELASSENE, STRUKTURIERTE UND VORGESCHLIFFENE OBERFLÄCHEN/ SURFACES NATURELLES, STRUCTURÉES ET PREPOLIES ****

* Scostamenti medi per lastre rettificate - 0,2% per collezioni non rettificate
Average gap for rectified tiles - 0,2% for not rectified collections
Durchschnittliche Kluft für rektifizierte Fliesen - 0,2% für nicht rektifizierte Kollektionen
Écart moyen pour les carreaux rectifiés - 0,2% pour les collections pas rectifiées

** Test effettuato su Pietre Naturali High-Tech satinata e su Marmi High-Tech prelevigati
Test performed on satin-finish Pietre Naturali High-Tech and on prepolished Marmi High-Tech
Test mit satinierter Pietre Naturali High-Tech und mit vorgeschliffenem Marmi High-Tech durchgeführt
Essai effectué sur Pietre Naturali High-Tech satiné et sur Marmi High-Tech prépolis

*** Test effettuato su Pietre Naturali High-Tech 60x60
Test performed on Pietre Naturali High-Tech 60x60
Test mit Pietre Naturali High-Tech 60x60 durchgeführt
Essai effectué sur Pietre Naturali High-Tech 60x60

**** Vedi tabella Safe System /
See Safe System table /
Siehe Tabelle Safe System /
Voir tableau Safe System

Standards ANSI/ASTM disponibili a richiesta /
ANSI/ASTM standards available on demand /
ANSI/ASTM standards verfügbare auf Anfrage /
ANSI/ASTM standards disponibles sur demande

BRITISH PENDOLUM TEST

IN ACCORDANCE WITH BRITISH STANDARD BS 7976 - 2:2002

COLLEZIONE ARIOSTEA ARIOSTEA COLLECTIONS KOLLEKTION ARIOSTEA COLLECTION ARIOSTEA	SUPERFICIE SURFACE OBERFLÄCHE SURFACE	RISULTATO SU ASCIUTTO RESULT ON DRY ERGEBNIS WENN TROCKEN RÉSULTAT À SEC	RISULTATO SU BAGNATO RESULT ON WET ERGEBNIS WENN NASS RÉSULTAT À MOUILLÉ
PIETRE NATURALI HIGH-TECH	Strutturato / Structured Strukturisiert / Structurée	Low slip potential 36+	Low slip potential 36+
	Satinato / Satin-finish Satinier / Satiné *	Low slip potential 36+	Moderate slip potential 25-35
GREENSTONE	Strutturato / Structured Strukturisiert / Structurée **	Low slip potential 36+	Low slip potential 36+
MARMI HIGH-TECH	Prelevigato / Prepolished Vorgeschliffen / Prépoli ***	Low slip potential 36+	Moderate slip potential 25-35

* Test effettuato su Pietra di Merano Satinato / Test performed on satin-finish Pietra di Merano / Test mit satinierte Pietra di Merano durchgeführt / Essai effectué sur Pietra di Merano satiné

** Test effettuato su Quarzite Bianca Strutturato / Test performed on structured Quarzite Bianca / Test durchgeführt auf Quarzite Bianca strukturisiert / Essai effectué sur Quarzite Bianca structuré

*** Test effettuato su Nero Marquina Prelevigato / Test performed on prepolished Nero Marquina / Test mit vorgeschliffene Nero Marquina durchgeführt / Essai effectué sur Nero Marquina prépoli

SPANISH PENDOLUM TEST

ENV12633

COLLEZIONE ARIOSTEA ARIOSTEA COLLECTIONS KOLLEKTION ARIOSTEA COLLECTION ARIOSTEA	SUPERFICIE SURFACE OBERFLÄCHE SURFACE	CLASSE CLASS KLASSE CLASSE
PIETRE NATURALI HIGH-TECH	Strutturato / Structured / Strukturisiert / Structurée	2
	Satinato / Satin-finish / Satinier / Satiné *	2
MARMI HIGH-TECH	Prelevigato / Prepolished / Vorgeschliffen / Prépoli **	1
LENGNI HIGH-TECH	Anticato / Antique / Antik / Antique ***	2

* Test effettuato su Limra Satinato / Test performed on satin-finish Limra / Test mit satinierte Limra durchgeführt / Essai effectué sur Limra satiné

** Test effettuato su Nero Marquina Prelevigato / Test performed on prepolished Nero Marquina / Test mit vorgeschliffene Nero Marquina durchgeführt / Essai effectué sur Nero Marquina prépoli

*** Test effettuato su Rovere Moka e Rovere Biondo / Test performed on Rovere Moka and Rovere Biondo / Test mit Rovere Moka und Rovere Biondo durchgeführt / Essai effectué sur Rovere Moka et Rovere Biondo

INFORMAZIONI TECNICHE AGGIUNTIVE / ADDITIONAL TECHNICAL INFORMATION / ZUSÄTZLICHE TECHNISCHE INFORMATIONEN / INFORMATION TECHNIQUE SUPPLÉMENTAIRE

- La trasformazione di materie prime naturali, associata all'utilizzo di innovative tecnologie di produzione brevettate, consente di ottenere materiali dalle elevate prestazioni tecniche, che si distinguono per i tipici effetti a tutto spessore da sempre prerogativa esclusiva dei marmi e delle pietre di cava.
- Le variazioni cromatiche, di venatura e le piccole puntature sono pertanto caratteristiche di alto pregio dei materiali Ariostea, ricercate e volute proprio al fine di ricreare la suggestione di una pavimentazione esclusiva, in cui si possa riscoprire la casualità e la bellezza dei materiali naturali. In ragione di quanto sopra i riferimenti cromatici presentati su cataloghi e campionature sono da intendersi puramente indicativi.
- Le lastre delle collezioni High-Tech sono realizzate in massa unica, compatta, ingeliva e resistente agli attacchi chimici. Esse sono pertanto una garanzia di stabilità e durezza nel tempo, idonee a qualunque impiego e ad ogni ambiente sia interno che esterno, dal più classico e raffinato, al più ampio e di intenso utilizzo.

- The processing of natural raw materials, combined with the use of leading-edge patented production techniques, makes it possible to obtain high-tech materials characterized by typical full-body effects, a feature that has always been the exclusive hallmark of quarried marble and stone.
- Chromatic variations, veining and speckling are thus prized characteristics of Ariostea materials, designed and produced to recreate the fascination of exclusive floorings, that reveal the randomness and beauty of natural materials. On the basis of the above statements, the colour references in the catalogues and samples are to be considered as approximate.
- The slabs of the High-Tech collections are realized with a 100% full body, a compact and frost-proof mass and they are resistant to chemical attacks. For this reason they are a guarantee of stability and durability in the time, suitable for whatever use and destination, both interior and exterior, from the more classic and refined, to the most spacious and of intense utilization one.

- Die Umwandlung von natürlichen Rohmaterialien mit Hilfe von innovativen und patentierten Produktionstechnologien, ermöglicht die Herstellung von Materialien mit hoher technischer Leistungsfähigkeit, die sich durch die typischen vollgemischten Effekte unterscheiden und die seit jeher die charakteristische Besonderheit der Marmorarten und der Steine aus dem Steinbruch sind.
- Die farblichen Unterschiede, die Aderungen und die kleinen Punkte sind aus diesem Grund charakteristische Eigenschaften der Materialien Ariostea von besonderem Wert. Diese "Unvollkommenheiten" sind besonders gewährt und gewollt, um einen exklusiven Bodenbelag zu erzielen, bei dem die Zufälligkeit und die Schönheit der natürlichen Materialien voll zum Ausdruck kommen können. Angesichts der oben aufgeführten Tatsache sind die Farben der Kataloge und der Muster unverbindlich.
- Die Platten der Kollektionen High-Tech werden in einziger, vollgemischter, kompakter, frost- und chemikalienbeständiger Masse hergestellt. Deshalb sind sie eine Garantie für Stabilität und Haltbarkeit im Laufe der Zeit, geeignet für jegliche Nutzung und für jedes Ambiente, sowohl für Innen- als Außenbereiche, von den klassischsten und raffiniertesten, bis zu den größten mit intensiver Nutzung.

- La transformation de matières premières naturelles, allée à l'application de technologies de production d'avant-garde brevetées, permet d'obtenir des matériaux capables de performances techniques élevées se distinguant par leurs effets pleine masse typiques qui sont depuis toujours la prerogative exclusive des marbres et des pierres de carrière.
- Les variations chromatiques, les veines et les petits points sont donc des caractéristiques de grande valeur des matériaux Ariostea, recherchées et voulues dans le but de recréer la suggestion d'un sol exclusif grâce auquel il est possible de redécouvrir l'impondérable et la splendeur des matériaux naturels. C'est la raison pour laquelle les références chromatiques présentées sur les catalogues et les échantillons ne sont données qu'à titre indicatif.
- Les dalles de les collections High Tech sont réalisées en une unique masse, compacte, résistante au gel et aux attaches chimiques. Ces dalles sont donc une garantie de stabilité et durabilité dans le temps, elles sont indiquées pour toute utilisation soit pour l'intérieur que l'extérieur, pour tous endroits de plus classique et raffiné au plus large et à grand passage.

- Per ottenere un ottimo risultato estetico è preferibile posare il materiale con una fuga di 2-3 mm utilizzando stuccatura in tinta. Ariostea si riserva di apportare modifiche senza preavviso ai prodotti, declinando ogni responsabilità per danni diretti o indiretti da eventuali modifiche.

Ultra Ariostea prevede un certo numero di facce differenti, a parità di prodotto, per creare una gradevole variabilità estetica nella posa. In fase di approntamento dell'ordine la selezione delle facce è random quindi la venatura continua tra i pezzi ordinati non è garantita. Ultra è un prodotto derivante dalla combinazione della terra con il fuoco. La eventuale continuità di venatura tra un pezzo e l'altro è soggetta alla tolleranza tipica dei prodotti naturali.

- For a better aesthetic result, is preferable to spread out the material with a 2-3 mm of joint, jointing with tone on tone colours. Ariostea keeps the right to change all the mentioned items without notice and declining any responsibility for direct or indirect damage caused from these changes.

Ultra Ariostea, compared with an equal product, provides a number of different faces, to create a pleasant aesthetic variability in the laying. In the order preparation phase, the face selection is random and therefore the continuous veining between the ordered pieces is not guaranteed. Ultra is a product derived from a combination of earth with fire. The continuous veining between pieces is subject to the typical variation of natural products.

- Um eine optimale Ästhetik zu erreichen, es ist vorzuziehen, das Material mit einer Fuge von 2-3 mm zu verlegen und Verfügungen in ähnlichen Farbtönen zu verwenden. Ariostea behält sich vor, ohne Ankündigung Änderungen an den Produkten vorzunehmen, und lehnt jede Haftung für direkte oder indirekte Schäden durch eventuelle Änderungen ab.

Ultra Ariostea - sieht eine gewisse Anzahl verschiedenartig gestalteter Oberflächen für dasselbe Produkt vor, um damit ansprechende ästhetische Variablen beim Verlegen erzielen zu können. Bei der Zusammenstellung der Bestellung wird die Auswahl der Oberflächen dem Zufall überlassen, sodass ein gleichförmiger Verlauf der Maserung zwischen den bestellten Stücken nicht gesichert ist. Ultra- ist ein Produkt, das aus dem Zusammenspiel von Erde und Feuer entstammt. Der eventuell kontinuierliche Verlauf der Maserung zwischen dem einem und dem anderen Stück unterliegt der typischen Toleranz von natürlichen Produkten.

- Pour obtenir un excellent résultat esthétique, est préférable de poser le matériau avec un joint de 2-3 mm utilisant le Jointoiment en couleurs ton sur ton. Ariostea se réserve le droit d'apporter, sans préavis, des modifications aux produits, et décline toute responsabilité pour dommages directs ou indirects, des éventuelles modifications.

Ultra Ariostea prévoit un certain nombre de faces différentes, pour un même produit, pour créer une agréable variabilité esthétique dans la pose. En phase de préparation de la commande, la sélection des faces est aléatoire donc le grain continu entre les pièces commandées ne peut pas être garanti. Ultra est un produit dérivé de la combinaison de la terre et du feu. La continuité éventuelle dans le grain entre une pièce et une autre est soumise à la tolérance typique des produits naturels.

I punti di forza che sotto il profilo ambientale e qualitativo caratterizzano la produzione di Ariostea sono:

- > utilizzo di materie prime naturali a basso impatto ambientale, in quanto ampiamente diffuse sulla crosta terrestre e non a rischio di esaurimento (come invece si verifica per alcuni materiali lapidei);
- > processi produttivi ad elevate performance qualitative ed ambientali, ciò grazie a fonti energetiche pulite come il gas metano per la produzione di energia termica;
- > ridottissimi consumi di acqua industriale, attraverso la creazione di impianti di trattamento e riciclo completo delle acque reflue industriali, provenienti soprattutto dai lavaggi degli impianti, e l'attivazione di un sistema di approvvigionamento di acqua industriale (acqua di fiume appositamente trattata). Tutto ciò permette una drastica riduzione dei consumi idrici industriali, l'eliminazione di qualsiasi scarico di acque reflue e, soprattutto, un inesistente utilizzo di acqua potabile;
- > ciclo dei materiali chiuso: ovvero non esiste generazione di scarti durante la lavorazione, grazie al sistema di recupero ed al riutilizzo di tutti i residui adottato da Ariostea;
- > riciclaggio ottimale dei rifiuti differenziati;
- > durabilità nel tempo senza particolari necessità di manutenzione, grazie alle ottime caratteristiche di igiene e di praticità dei prodotti Ariostea;
- > elevata compatibilità allo smantellamento del pavimento/rivestimento, come definito dalle attuali legislazioni. In particolare, i residui derivanti dallo smantellamento, in ragione della loro inerzia, non richiedono trattamenti particolari e possono facilmente essere riutilizzati come inerti non rilasciando alcun genere di sostanza pericolosa e non.

Per quanto riguarda la qualità certificata, Ariostea vanta, da sempre, le più importanti certificazioni nel settore:

The salient features of Ariostea's production, in terms of environment and quality, are as follows:

- > Use of natural raw materials that ensure minimal environmental impact, being broadly available in the earth's crust and not at the risk of depletion (as in the case of various types of stone);
- > Production processes of a high quality and environmental standard, using clean sources of energy such as methane gas for the production of heat energy;
- > Minimal industrial consumption of water. We use plants that treat and recycle all industrial waste water used mainly for cleaning the equipment, as well as an industrial water supply system (which uses appropriately treated river water). This serves to drastically reduce our industrial consumption of water, eliminates virtually all disposal of waste water and, above all, ensures we do not use any potable water;
- > Closed work cycle: this means no waste is generated during the work phase due to Ariostea's system that recovers and reuses all residue;
- > Optimal recycling of segregated waste;
- > Long-lasting durability, without any particular need for maintenance due to the excellent standards of hygiene and practicality of Ariostea's products;
- > The floor/wall tiles are designed in such a way that they can be easily taken up again, as per the law in force. In particular, any residue created when taking up the tiles does not require special treatment due to its inertia and can be easily re-used as inert matter without releasing any substances, dangerous or otherwise.

With regard to certified quality, Ariostea has always been able to boast the most important certification in the field:



SISTEMA DI GESTIONE AMBIENTALE CERTIFICATO UNI EN ISO 14001

Certified environmental
management system.
Umweltschutzsystem zertifiziert.
Gestion environnementale certifiée.

Certificazione ISO 14001 per il proprio Sistema di Gestione Ambientale, che riconosce la validità delle misure adottate dall'azienda per salvaguardare l'ambiente interno ed esterno. Con questa certificazione la nostra azienda conferma il suo impegno nell'assicurare il rispetto delle leggi relative all'ambiente e alla sicurezza, e nel gestire, preservare e ove possibile diminuire, l'utilizzo di risorse naturali e prevenire o ridurre al minimo l'inquinamento.

ISO 14001 certification for its Environmental Management System, validating the company's measures with to protect the environment both in-house and out-house. This certification our company confirms dedication to conform to environmental and safety regulations and to manage, preserve and, when possible, cut down on the use of natural resources and prevent or minimize pollution.

Zertifikat ISO 14001 für das unternehmenseigene Umweltmanagement-System, mit dem die Gültigkeit der vom Unternehmen für den Umweltschutz ergriffenen Maßnahmen innerhalb und außerhalb des Werks anerkannt wird. Mit diesem Zertifikat bekräftigt das Unternehmen sein Bestreben zur Einhaltung der Umwelt- und Sicherheitsgesetze. Außerdem wird versucht, den Einsatz der natürlichen Ressourcen stets auf dem gleichen Stand zu halten und diesen sofern möglich zu verringern. Dazu wird angestrebt, die Umweltbelastung zu vermeiden oder auf ein Minimum zu reduzieren.

Certification ISO 14001 pour son Système de Gestion Environnementale, qui reconnaît la validité des mesures adoptées par l'entreprise pour préserver l'environnement dans ses propres installations et à l'extérieur. Grâce à cette certification, confirme son engagement pour assurer le respect des lois relatives à l'environnement et à la sécurité et à gérer, préserver et dans la mesure du possible à réduire l'utilisation de ressources naturelles et à prévenir ou réduire au minimum la pollution.



SISTEMA DI GESTIONE QUALITÀ CERTIFICATO UNI EN ISO 9001

Certified quality system.
Qualitätssystem zertifiziert.
Système qualité certifiée.

Certificazione ISO 9001 per la gestione del sistema di Qualità aziendale.

La certificazione, valida a livello internazionale, riguarda l'intera gestione aziendale, dalla ricerca e sviluppo alla produzione, dalla distribuzione all'assistenza al cliente.

ISO 9001 certification for management of its company quality system. This certification, valid at the international level, concerns the entire company management system, from research and development to production, and from distribution to customer service.

Zertifikat ISO 9001 für die Verwaltung des unternehmenseigenen Qualitätsmanagementsystems.

Diese internationale anerkannte Zertifizierung betrifft die gesamte Unternehmensführung, von Forschung und Entwicklung, über die Produktion bis hin zu Vertrieb und Kundendienst.

Certification ISO 9001 pour la gestion du système Qualité de l'entreprise.

La certification, valable au niveau international, concerne tout le système de l'usine, de la recherche et développement à la production, à la distribution et à l'assistance au client.

Die Stärken, welche die Produktion von Ariostea in Hinsicht auf Umweltschutz und Qualitätsgesichtspunkte kennzeichnen, sind:

- > Die Verwendung von natürlichen Rohmaterialien mit geringer Umweltbelastung, die dank ihres häufigen Vorkommens keine Gefahr der Erschöpfung laufen (wie das dagegen bei einigen Steinmaterialien der Fall ist);
- > Herstellungsverfahren mit hoher Leistung in punkto Qualität und Umwelt, dies auch dank sauberer Energiequellen wie Methangas zur Erzeugung von thermischer Energie;
- > Extrem geringer Industriewasserverbrauch dank der Einrichtung von Wiederaufbereitungsanlagen für die Behandlung und das komplette Recycling der industriellen Abwässer, die vor allem von den Waschvorgängen der Anlagen stammen, sowie die Aktivierung eines Versorgungssystems für Industriewasser (entsprechend behandeltes Flusswasser). All dies ermöglicht eine drastische Verringerung des industriellen Wasserverbrauchs, das Entfallen jeglicher Art der Abwasserentsorgung und was wesentlich wichtiger ist, absolut keinen Einsatz von Trinkwasser;
- > Ein geschlossener Materialzyklus: das bedeutet, dass dank des von Ariostea eingesetzten Wiedergewinnungs- und Wiederverwertungssystems sämtlicher Rückstände während der Verarbeitung keine Abfälle erzeugt werden;
- > Optimale Wiederverwertung der getrennten Abfälle;
- > Eine zeitlose Dauerhaftigkeit ohne besondere Wartungsmaßnahmen dank der optimalen hygienischen Eigenschaften und der Zweckmäßigkeit der Produkte von Ariostea;
- > Hohe Abrissverträglichkeit des Bodenbelags/der Wandverkleidung, so wie es die derzeitige Gesetzgebung verlangt. Insbesondere erfordern die Abrissrückstände keine besonderen Behandlungsverfahren und können leicht als inerte Stoffe wieder verwendet werden, da sie keine Art von Gefahrenstoffen beinhalten oder freigeben.

Was die Qualitätszertifikation angeht, kann sich Ariostea seit jeher der wichtigsten Bestätigungen dieser Branche rühmen:

Les points forts qui sous le profil environnemental et qualitatif caractérisent la production d'Ariostea sont:

- > utilisation de matières premières naturelles à faible impact environnemental, largement répandues sur l'écorce terrestre et qui ne risquent pas de s'épuiser (comme cela est au contraire le cas pour certains matériaux lapidaires);
- > processus de production ayant des performances qualitatives et environnementales élevées, grâce à des sources énergétiques propres comme le gaz méthane pour la production d'énergie thermique;
- > consommation d'eau industrielle extrêmement réduite, grâce à la création d'installations de traitement et de recyclage complet des eaux industrielles usées, provenant surtout des lavages des installations, et l'activation d'un système d'approvisionnement d'eau industrielle (eau de fleuve correctement traitée). Tout ceci permet une réduction importante des consommations hydriques industrielles, l'élimination des évacuations d'eaux usées et, surtout, une utilisation inexistante d'eau potable ;
- > cycle fermé des matériaux : c'est-à-dire lorsqu'il n'y a pas de déchets générés au cours de la fabrication, grâce au système de recyclage et d'utilisation de l'ensemble des rebuts, adopté par Ariostea;
- > recyclage optimal des déchets différenciés;
- > durabilité dans le temps, sans aucun entretien, grâce aux excellentes propriétés d'hygiène et d'utilisation des produits d'Ariostea;
- > excellente compatibilité au moment de la destruction des dalles/revêtements telle que préconisée par les législations actuelles. Notamment pour les déchets provenant de la destruction, en raison de leur inertie, qui ne demandent aucun traitement particulier et qui peuvent être facilement réutilisés en tant qu'inertes qui ne génèrent aucune substance dangereuse.

En ce qui concerne la certification de la qualité, Ariostea possède depuis toujours les plus importants certificats dans son domaine:



Iscrizione al Registro EMAS, uno degli strumenti con cui la Comunità Europea interviene per la tutela dell'ambiente, allo scopo di realizzare uno sviluppo economico sostenibile, mettendo in rilievo il ruolo e la responsabilità delle imprese. La nostra Azienda ha quindi deciso di aderire al programma EMAS per perseguire obiettivi di miglioramento costante della propria efficienza ambientale e di trasparenza nei confronti dell'opinione pubblica.

Registration with EMAS, the EU's eco-management scheme that aims for sustainable economic development and stresses the role and responsibility of businesses in this regard. Our Company joined EMAS with the intention of constantly improving upon environmental efficiency and transparent relations with the public.

Eintragung in das EMAS-Register, eines der Systeme, mit denen die Europäische Gemeinschaft zum Schutz der Umwelt eingreift, um eine nachhaltige wirtschaftliche Entwicklung zu erreichen, indem sie die Rolle und die Verantwortlichkeit der Unternehmen in den Vordergrund rückt. Unser Unternehmen hat sich daher entschlossen, sich dem EMAS-Programm anzuschließen und das Ziel einer beständigen Verbesserung in Bezug auf Umwelteffizienz und Transparenz gegenüber der öffentlichen Meinung zu verfolgen.

Inscription au Registre EMAS, l'un des outils grâce auxquels la Communauté européenne intervient pour la protection de l'environnement, afin de réaliser un développement économique durable, en mettant en avant le rôle et la responsabilité des entreprises. Notre Société a donc choisi d'adhérer au programme EMAS pour poursuivre les objectifs d'amélioration constante de sa propre efficacité environnementale et de transparence vis-à-vis du grand public.



CERTIFICAZIONE LEED: Già diffusa ed attiva in oltre 40 Paesi, il sistema di certificazione LEED (Leadership in Energy and Environmental Design) valuta ed attesta la sostenibilità ambientale, sociale ed economica degli edifici considerati nel loro complesso. Secondo i criteri di classificazione LEED, i materiali da costruzione con elevata ecosostenibilità contribuiscono all'ottenimento di crediti elevando il punteggio dell'edificio. Si certifica che le lastre Ariostea presentate in questo strumento contengono una percentuale di impasto riciclato (pre consumer) superiore al 40% : garantiscono quindi i più alti punteggi secondo il sistema LEED.

CERTIFICAZIONE BREEAM: E' tra i più diffusi standard al mondo ed è volto a misurare l'impatto ambientale degli edifici mediante l'applicazione di specifici criteri di valutazione della sostenibilità della costruzione. il sistema di assegnazione del punteggio prevede tipologie di certificazione fissati da rigorosi parametri tecnici e di controllo qualità basati sulle più recenti tecnologie e conoscenze disponibili.

LEED CERTIFICATION: Currently widespread and used in over 40 countries, the certification system LEED (Leadership in Energy and Environmental Design) evaluates and certifies social and economic environmental sustainability of buildings considered as a whole. According to the classification criteria of LEED, building materials having a high environmental sustainability contribute to obtaining credits thus increasing the building's rating. We certify that the Ariostea tiles in question contain more than 40% (pre-consumer) recycled material: therefore they guarantee the highest LEED ratings.

BREEAM CERTIFICATION: It is the most widespread standard in the world and it is designed to measure the environmental impact of buildings by applying specific criteria for assessing the sustainability of the construction. The rating system requires types of certification determined by strict technical parameters and quality control which in turn are based on the most recent technology and knowledge available.

**CERTIFICAZIONI DI PRODOTTO / PRODUCT CERTIFICATIONS /
PRODUKTPRÜFBERICHTE / CERTIFICATIONS DE PRODUIT/**

ITALY



Centro Ceramico
Bologna Italy

U.S.A.



American Society
for Testing and Materials

FRANCE



UKRAINE



RUSSIA



State Sanitary-Epidemic
Department of Russian Federation

Certificazioni di prodotto

Certificazioni rilasciate per i materiali Ariostea dai seguenti organismi ufficiali.

Product certifications

Certifications issued for Ariostea materials by the following official bodies.

Produktprüfberichte

Diese prüfberichte sind für die Materialien Ariostea von den folgenden öffentlichen Behörden ausgestellt worden

Certifications de produit

Certifications délivrées pour les matériaux Ariostea par les organismes officiels suivants:

* La liste à jour des matériaux Ariostea certifiés UPEC est disponible sur le site internet www.cstb.fr

LEED-ZERTIFIZIERUNGEN: Das bereits in mehr als 40 Ländern präsente und aktive Zertifizierungssystem LEED (Leadership in Energy and Environmental Design) prüft und bestätigt die umweltfreundliche, soziale und ökonomische Nachhaltigkeit der Bauten in ihrer Gesamtheit. Den Klassifizierungskriterien von LEED entsprechend tragen hochrangig ökonachhaltige Baumaterialien dazu bei, Pluspunkte für das Gebäude zu sammeln.

Es wird bestätigt, dass die in diesem Instrument vorgelegten Ariostea-Platten einen Prozentsatz von mehr als 40 % an wiederverwerteter Mischung (pre-consumer) enthalten: Sie gewährleisten also nach dem LEED-System die höchsten Punktezahlen.

BREEAM-ZERTIFIZIERUNG: Sie gehört zu den weltweit am meisten verbreiteten Standards und dient dazu, die Umweltbelastung der Gebäude mit speziellen Beurteilungskriterien der Nachhaltigkeit des Baus zu bemessen. Die Zuerkennung der Punktebewertung sieht Zertifizierungen vor, die nach strengen, auf den neuesten Technologien und Erkenntnissen aufbauenden Maßstäben von Technik und Qualitätskontrolle festgelegt sind.

CERTIFICATION LEED: Déjà présent et actif dans plus de 40 Pays, le système de certification LEED (Leadership in Energy and Environmental Design) évalue et certifie la compatibilité environnementale, sociale et économique des bâtiments dans leur ensemble. Conformément aux critères de classification LEED, les matériaux de construction à éco-durabilité élevée favorisent l'obtention de crédits en faisant monter la cote du bâtiment. Les plaques carrelages Ariostea présentées dans ce document contiennent un pourcentage de gâchage recyclé (pré-consommateur) de plus de 40 %: elles obtiennent donc les scores les plus élevés selon le système LEED.

CERTIFICATION BREEAM: C'est l'une des normes les plus répandues au monde et elle permet de mesurer l'impact environnemental des bâtiments selon des critères précis d'évaluation de la durabilité de la construction. Le système d'attribution du score prévoit des types de certification établis selon des paramètres techniques rigoureux et des contrôles qualité basés sur technologies et les connaissances disponibles les plus récentes.

**MARCHIO CE / CE MARK /
CE ZEICHEN / MARQUE CE**



Indica che i prodotti Ariostea sono conformi a quanto richiesto dal regolamento UE 1221/09, in particolare ai requisiti di protezione e sicurezza per il consumatore e che perciò possono liberamente circolare all'interno del Mercato Comune. Per visualizzare le dichiarazioni di conformità di ogni singolo prodotto Ariostea, consultare il sito www.ariostea.it.

It indicates that Ariostea products comply with the requirements of 1221/09 UE directive – in particular with regard to health production and the users and consumers' safety – and may thus be freely circulated on the Community market. For the declarations of conformity of each single product, please refer to www.ariostea-high-tech.com website.

Es bedeutet dass die Ariostea Produkte der Europäischen 1221/09 UE in besonderen den Schutz – und Sicherheitsnormen dem Verbraucher gegenüber entsprechen. Aus diesem Grund dürfen sie auf dem ganzen Gemeinsamen Markt frei umlaufen. Konformitätserklärungen finden Sie auf der Webseite www.ariostea.biz.

Cette marque signifie que les produits de Ariostea respectent la Directive UE 1221/09 sur les normes de sûreté et de protection du consommateur et qui peuvent circuler librement dans le Marché Commun. Pour les déclarations de conformité de chaque produit, veuillez visiter le site Internet www.ariostea.eu.

SAFE SYSTEM

CLASSIFICAZIONE RESISTENZA ALLO SCIVOLAMENTO / SLIP RESISTANCE CLASSIFICATION /
KLASSIFIZIERUNG DER RUTSCHFESTIGKEIT / RÉSISTANCE AU GLISSEMENT



NORMA DIN 51130

R9
6° - 10°

COEFFICIENTE DI ATTRITO NORMALE
AVERAGE FRICTION COEFFICIENT
NORMALER REIBUNGSKOEFFIZIENT
COEFFICIENT DE FROTTEMENT MOYEN

COLLEZIONE /
COLLECTION /
KOLLEKTION /
COLLECTION

FINITURA / FINISH /
OBERFLÄCHEN
AUSFÜHRUNG /
FINITION

DIN 51097

ULTRA MARMI		SO	-
ULTRA IRIDIUM		SO	-
ULTRA ICEMENTI		SO	-
ULTRA PIETRE		SO	-
ULTRA RESINE		SO	-
ULTRA WOOD		SO	-
MATERIE HIGH-TECH	CENERE	SO	-
	GESSO	SO	-
	FANGO	SO	-
	SABBIA	SO	-
	LAVA	SO	-
	LIGNITE	SO	-
	GHIACCIO	SO	-
	DIORITE	SO	-
	PELTRO	SO	-
PIETRE NATURALI HIGH-TECH	CREMA EUROPA	SA	-
	PIETRA D'AVOLA	N	A
	PIETRA DI BARGE	SA	-
	PIETRA DI BRUGGE	AN	A
	PIETRA DI CALAIS	AN	A
	PIETRA DI ESSEN	AN	A
	PIETRA DI LUSERNA	SA	-
	PIETRA DI ROUBAIX	AN	A
	PIETRA DI UTRECH	AN	A
	PIETRA GIALLA	SA	-
	PIETRA PIASENTINA	SA	-
	SILK GEORGETTE	N	A+B
MARMI HIGH-TECH	AVORIO DI SICILIA	PR	-
	BIANCO PAONAZZETTO	PR	-
	BOTTICINO	PR	-
	CREMA MARFIL	PR	-
	DARK EMPERADOR	PR	-
	ESTREMOZ	PR	-
	GIALLO DI SIENA	PR	-
	GRIGIO DEI CARPAZI	PR	-
	NERO MARQUINIA	PR	-
	NOIR ST. LAURENT	PR	-
	ROSA PORTOGALLO	PR	-
	ROSSO ALICANTE	PR	-
	SKYROS	PR	-
	STATUARIO	PR	-
	THASSOS	PR	-
	TRAVERTINO NAVONA	PR	-
	VERDE ALPI	PR	-
LEGNI HIGH-TECH	ROVERE BIONDO	AN	A
	ROVERE SABBIA	AN	A
WOODRAW	ARTIC	AN	-
	ASH	AN	-
	BOARD	AN	-
	POWDER	AN	-
	RUST	AN	-

STARDUST PR -

PORFIDO N A

NORMA DIN 51130

R10
10° - 19°

COEFFICIENTE DI ATTRITO NORMALE
AVERAGE FRICTION COEFFICIENT
NORMALER REIBUNGSKOEFFIZIENT
COEFFICIENT DE FROTTEMENT MOYEN

COLLEZIONE /
COLLECTION /
KOLLEKTION /
COLLECTION

FINITURA / FINISH /
OBERFLÄCHEN
AUSFÜHRUNG /
FINITION

DIN 51097

ULTRA PIETRE		ST	-
MATERIE HIGH-TECH	CENERE	N	A+B
	GESSO	N	A+B
	FANGO	N	A+B
	SABBIA	N	A+B
	LAVA	N	A+B
	LIGNITE	N	A+B
	GHIACCIO	N	A+B
	DIORITE	N	A+B
	PELTRO	N	A+B
PIETRE NATURALI HIGH-TECH	ARDESIA ANTRACITE	SL	A
	BASALTO GRIGIO	SA	A+B+C
	BLACK ARDESIA	SA	-
	BLACK ARDESIA	ST	A+B
	CADAPPA BLACK	SL	A
	GREEN QUARZITE	ST	A+B
	LIMRA	SA	A+B
	PIETRA DI BORGOGNA	SA	A+B+C
	PIETRA DI BRUGGE	SO	A+B
	PIETRA DI CALAIS	SO	A+B
	PIETRA DI ESSEN	SO	A+B
	PIETRA DI MERANO	SA	A+B+C
	PIETRA DI ROUBAIX	SO	A+B
	PIETRA DI UTRECH	SO	A+B
	PIETRA SINTRA	SL	A
	QUARZITE BIANCA	SL	A
	SILVER GREY	SL	A
	TRAVERTINO CHIARO	N	A
INNOVATIVE SLABS LEGNI HIGH-TECH	QUERCIA TROPICALE	AN	A+B
	QUERCIA PETRAEA	AN	A+B
	QUERCIA BIANCA	AN	A+B
	QUERCIA CANADESE	AN	A+B
	QUERCIA SHABBY	AN	A+B
LEGNI HIGH-TECH	ROVERE ABBAZIA	AN	A
	ROVERE ANTICO	AN	A
	ROVERE BIANCO	AN	A+B+C
	ROVERE CENERE	AN	A+B
	ROVERE CILIEGIO	AN	A+B
	ROVERE CORDA	AN	A
	ROVERE COUNTRY	AN	A
	ROVERE DECAPÈ	AN	A
	ROVERE IMPERO	AN	A
	ROVERE NATURALE	AN	A+B
	ROVERE NOCE	AN	A+B
	ROVERE PROVENZALE	AN	A+B
	ROVERE REALE	AN	A
	ROVERE TUNDRA	AN	A
UNIVERSE		SA	A

AN: Anticato / Antiqued / Antik / Antique
BA: Bamboo
BC: Bocciardato / Bushhammered / Gestockt / Bouchardé
HH: High-Honed
LL: Levigato e lucidato / Honed and polished / Geschliffen und poliert / Poli et lustré
N: Naturale / Natural / Naturbelassen / Naturel
PR: Prelevigato / Prepolished / Vorgeschliffen / Prépoli
SA: Satinato / Satin-finish / Satiniert / Satiné
SL: Semilucidato / Semi-polished / Semi-matt / Semi-lustré
SO: Soft
ST: Strutturato / Structured / Strukturiert / Structuré

NORMA DIN 51130

R11
19° - 27°

COEFFICIENTE DI ATTRITO SUPERIORE ALLA NORMA
ABOVE AVERAGE FRICTION COEFFICIENT
ÜBERDURCHSCHNITTLICHER REIBUNGSKOEFFIZIENT
COEFFICIENT DE FROTTEMENT SUPERIEUR A LA NORME

COLLEZIONE /
COLLECTION /
KOLLEKTION /
COLLECTION

FINITURA / FINISH /
OBERFLÄCHEN
AUSFÜHRUNG /
FINITION

DIN 51097

PIETRE NATURALI HIGH-TECH	ARDESIA ANTRACITE	ST	A+B+C
	ARDESIA BORDEAUX	ST	A+B
	BASALTO GRIGIO	ST	A+B+C
	CADAPPA BLACK	ST	A+B
	CREMA EUROPA	ST	A+B
	LIMRA	ST	A+B+C
	PIETRA DELL'ESTEREL	ST	A
	PIETRA DI BARGE	ST	A+B
	PIETRA DI BORGOGNA	ST	A+B+C
	PIETRA DI BRUGGE	ST	A+B+C
	PIETRA DI CALAIS	ST	A+B+C
	PIETRA DI ESSEN	ST	A+B+C
	PIETRA DI LUSERNA	ST	A+B
	PIETRA DI MERANO	ST	A+B+C
	PIETRA DI RAGUSA	ST	A+B
	PIETRA DI ROUBAIX	ST	A+B+C
	PIETRA DI UTRECH	ST	A+B+C
	PIETRA GIALLA	ST	A+B
	PIETRA PIASENTINA	ST	A+B
	PIETRA SINTRA	ST	A+B+C
	QUARZITE BIANCA	ST	A+B+C
	SILVER GREY	ST	A+B+C
LEGNI HIGH-TECH	ROVERE BRICCOLA	AN	A+B
	ROVERE GRIGIO	AN	A
	ROVERE MOKA	AN	A+B
	ROVERE NERO	AN	A+B+C
CM2 - MATERIE HIGH-TECH	FANGO	CM2	A+B
	CENERE	CM2	A+B
	DIORITE	CM2	A+B
	PELTRO	CM2	A+B
CM2 - PIETRE NATURALI HIGH-TECH	PIETRA DI RAGUSA	ST	A+B
	PIETRA PIASENTINA	ST	A+B
	BASALTO GRIGIO	ST	A+B+C
	ABSOLUTE BLACK	ST	A+B
	CREMA EUROPA	ST	A+B
	GREEN QUARZITE	ST	A+B
	GREY STONE	ST	A+B
CM2 - LEGNI HIGH-TECH	ROVERE SABBIA	AN	A+B
	ROVERE CENERE	AN	A+B
	ROVERE BRICCOLA	AN	A+B
	ROVERE IMPERO	AN	A+B
	ROVERE GRIGIO	AN	A+B
	ROVERE TUNDRA	AN	A+B
UNIVERSE		BC	A+B+C
PORFIDO		ST	A

NORMA DIN 51130

R12
27° - 35°

COEFFICIENTE DI ATTRITO SUPERIORE ALLA NORMA
ABOVE AVERAGE FRICTION COEFFICIENT
ÜBERDURCHSCHNITTLICHER REIBUNGSKOEFFIZIENT
COEFFICIENT DE FROTTEMENT SUPERIEUR A LA NORME

COLLEZIONE /
COLLECTION /
KOLLEKTION /
COLLECTION

FINITURA / FINISH /
OBERFLÄCHEN
AUSFÜHRUNG /
FINITION

DIN 51097

PIETRE HIGH-TECH	TRAVERTINO NOCE	BA	A+B+C
	TRAVERTINO CHIARO	BA	A+B+C
	SILK GEORGETTE	BA	A+B+C
	PIETRA D'AVOLA	BA	A+B+C

**GRADO DI VARIAZIONE CROMATICA / DEGREE OF COLOUR CHANGE /
GRAD DER FARBABWEICHUNG / DEGRE DE VARIATION CHROMATIQUE**

ULTRA MARMI

ARABESCATO STATUARIO	V3
BIANCO COVELANO	V3
CREMA MARFIL	V2
ESTREMOZ	V2
ERAMOSA BROWN	V3
GRIS DE SAVOIE	V3
Paonazetto S	V3
STATUARIO ALTISSIMO	V3
STATUARIO ULTRA	V3
THASSOS ULTRA	V2
TRAVERTINO NAVONA	V2
TRAVERTINO SANTA CATERINA	V3
ZEBRINO BLACK	V2

ULTRA ONICI

ONICE BIANCO EXTRA	V3
ONICE BEIGE	V3
ONICE GRIGIO	V4

ULTRA RESINE

SILICIO	V2
CALCE	V2
PIOMBO	V2
EBANO	V2

ULTRA Pietre

BASALTINA ANTRACITE	V2
BASALTINA GREY	V2
BASALTINA MOKA	V2
BASALTINA SAND	V2
BASALTINA WHITE	V2
AZUL BATEIG LIMESTONE	V2
JERUSALEM LIMESTONE	V2
SAN VICENTE LIMESTONE	V2

ULTRA iCementi

BRONZE	V3
GRAPHITE	V3
IRON	V3
IVORY	V3
SILVER	V3

ULTRA IRIDIUM

BIANCO	V1
GRIGIO	V1
NERO	V1

ULTRA WOOD

NOCE AMERICANO	V3
NOCE CALCE	V3
NOCE CHIARO	V3
NOCE OSSIDATO	V3
NOCE SCURO	V3

MATERIE HIGH-TECH

CENERE	V3
GESSO	V3
FANGO	V3
SABBIA	V3
LAVA	V3
LIGNITE	V3
GHIACCIO	V3
DIORITE	V3
PELTRO	V3

MARMI HIGH-TECH

AVORIO DI SICILIA	V2
BIANCO PAONAZZETTO	V2
BOTTICINO	V2
CREMA MARFIL	V2
DARK EMPERADOR	V2
ESTREMOZ	V2
GIALLO DI SIENA	V3
GRIGIO DEI CARPAZI	V3
NERO MARQUINIA	V2
NOIR ST. LAURENT	V2
ROSA PORTOGALLO	V2
ROSSO ALICANTE	V2
SKYROS	V2
STATUARIO	V1
THASSOS	V1
TRAVERTINO NAVONA	V2
VERDE ALPI	V2

PIETRE NATURALI

HIGH-TECH

ARDESIA ANTRACITE	V2
ARDESIA BORDEAUX	V3
BASALTO GRIGIO	V3
BLACK ARDESIA	V2
CADAPPA BLACK	V2
CREMA EUROPA	V2
GREEN QUARZITE	V4
LIMRA	V2
PIETRA D'AVOLA	V2
PIETRA DELL'ESTEREL	V2
PIETRA DI BARGE	V3
PIETRA DI BORGOGNA	V4
PIETRA DI BRUGGE	V2
PIETRA DI CALAIS	V2
PIETRA DI ESSEN	V2
PIETRA DI LUSERNA	V2
PIETRA DI MERANO	V4
PIETRA DI RAGUSA	V2
PIETRA DI ROUBAIX	V2
PIETRA DI UTRECHT	V2
PIETRA GIALLA	V3
PIETRA PIASENTINA	V3
PIETRA SINTRA	V2
QUARZITE BIANCA	V2
SILK GEORGETTE	V2
SILVER GREY	V2

TRAVERTINO CHIARO	V3
TRAVERTINO NOCE	V3

INNOVATIVE SLABS

LEGNI HIGH-TECH

QUERCIA BIANCA	V3
QUERCIA CANADESE	V3
QUERCIA TROPICALE	V3
QUERCIA PETRAEA	V3
QUERCIA SHABBY	V2

LEGNI HIGH-TECH

ROVERE ABBAZIA	V3
ROVERE ANTICO	V3
ROVERE BIANCO	V2
ROVERE BIONDO	V4
ROVERE BRICCOLA	V2
ROVERE CENERE	V3
ROVERE CILIEGIO	V3
ROVERE CORDA	V3
ROVERE COUNTRY	V3
ROVERE DECAPÈ	V3
ROVERE GRIGIO	V4
ROVERE IMPERO	V4
ROVERE MOKA	V4
ROVERE NATURALE	V3
ROVERE NERO	V2
ROVERE NOCE	V4
ROVERE PROVENZALE	V3
ROVERE REALE	V4
ROVERE SABBIA	V3
ROVERE TUNDRA	V2

IRIDIUM

ARANCIO	V1
GRIGIO	V1
BIANCO	V1
BLU	V1
BROWN	V1
CHAMPAGNE	V1
GIALLO	V1
NERO	V1
ROSSO	V1
SKY	V1
VERDE	V1
VIOLET	V1

UNIVERSE

BROWN	V2
CREAM	V2
HONEY	V2
MIST GREY	V2
NIGHT BLUE	V2
OBSIDIAN	V2

TECNOPORCELAIN

PORFIDO

ALASKA	V1
BETEL	V1
CRYSTAL	V1
DETROIT	V1
HOUSTON	V1
KANSAS	V1
NEVADA	V1
OREGON	V1
SEATTLE	V1
TAMPA	V1
TEXAS	V1
TUCSON	V1

TECNOPORCELAIN

STARDUST

ARGENTÈ	V3
BRIQUE	V3
COBALT	V3
FUMÈ	V3
NOIR	V3
PASTEL	V3
SABLE	V3

CM2 - MATERIE HIGH-TECH

FANGO	V3
CENERE	V3
DIORITE	V3
PELTRO	V3

CM2 - PIETRE HIGH-TECH

CREMA EUROPA	V2
GREEN QUARZITE	V4
PIETRA DI RAGUSA	V2
PIETRA PIASENTINA	V3
BASALTO GRIGIO	V3
ABSOLUTE BLACK	V2
GREY STONE	V3

CM2 - LEGNI HIGH-TECH

ROVERE SABBIA	V3
ROVERE CENERE	V3
ROVERE BRICCOLA	V2
ROVERE IMPERO	V4
ROVERE GRIGIO	V4
ROVERE TUNDRA	V2

WOODRAW

ARTIC	V3
ASH	V3
BOARD	V4
POWDER	V4
RUST	V4

n.b: I valori di resistenza allo scivolamento, coefficiente di attrito statico o dinamico, riportati sul catalogo e nella tabella Safe System sono da ritenersi puramente indicativi e non vincolanti. Ogni eventuale specifica necessità dovrà essere da noi confermata al momento dell'ordine e comunque sempre prima della posa.

nb: Slip resistance values, coefficient of static or dynamic friction, in the catalog and in the Safe System Table are purely indicative and not binding.

Any specific requirements must be confirmed by us at the time of ordering and in any case before installation.

Anm.: Die Werte für die Rutschfestigkeit, also des statischen oder dynamischen Reibungskoeffizienten, die im Katalog oder in der Tabelle Safe System aufgeführt sind, sind als unverbindliche Richtwerte anzusehen. Alle spezifischen Anforderungen müssen von uns bei der Bestellung und in jedem Fall vor der Verlegung immer bestätigt werden.

n.b: Les valeurs de résistance au glissement, le coefficient de frottement statique ou dynamique, indiqués sur le catalogue et sur le tableau Safe System (Système de Sécurité) doivent être considérés comme purement indicatifs et ne sauraient engager notre responsabilité. Toutes les éventuelles spécifications nécessaires devront faire l'objet d'une confirmation de notre part au moment de la commande et en tout état de cause avant la pose.



V1 LOW

PRODOTTO MONOCROMATICO
MONOCHROMATIC PRODUCT
EINFARBIGES PRODUKT
PRODUIT MONOCHROMATIQUE



V2 MODERATE

PRODOTTO CON LEGGERA VARIAZIONE CROMATICA
PRODUCT WITH LIGHT CHROMATIC VARIATION
PRODUKT MIT LEICHTER FARBNUNANCE
PRODUIT À LÉGÈRE VARIATION CHROMATIQUE



V3 HIGH

PRODOTTO CON MARCATO VARIAZIONE CROMATICA
PRODUCT WITH HIGH SHADE CHROMATIC VARIATION
PRODUKT MIT AUSGEPRÄGTER FARBNUNANCE
PRODUIT À VARIATION CHROMATIQUE ACCENTUÉE



V4 EXTREME

PRODOTTO CON FORTE VARIAZIONE CROMATICA
PRODUCT WITH VERY HIGH SHADE CHROMATIC VARIATION
PRODUKT MIT STARKER FARBNUNANCE
PRODUIT À FORTE VARIATION CHROMATIQUE

ULTRA

CODICI E FORMATI / CODES AND SIZES /
ARTIKELNR. UND FORMATE / CODES ET FORMATS

SPESSORE: /
THICKNESS: /
DICKE: /
EPAISSEUR:

6 mm

FINITURA /
FINISH /
OBERFLÄCHENAUSFÜHRUNG /
FINITION

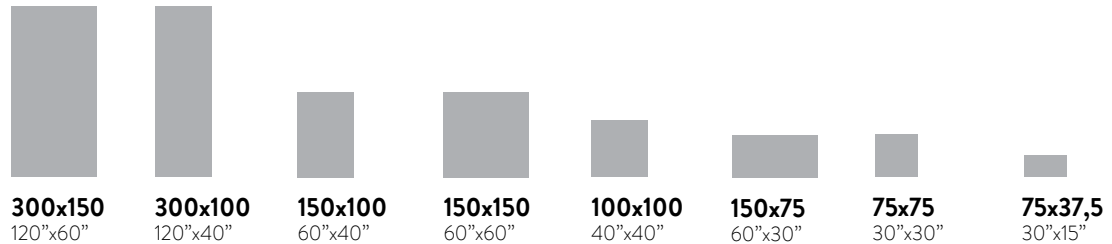

**ULTRA
MARM**

Paonazzetto S	SHINY	UM6L300382	-	-	UM6L150382	-	UM6L157382	UM6L75382	UM6L37382
	SOFT	UM6S300382	-	-	UM6S150382	-	UM6S157382	UM6S75382	UM6S37382
CREMA MARFIL	SHINY	UM6L300304	UM6L310304	UM6L151304	UM6L150304	UM6L100304	UM6L157304	UM6L75304	UM6L37304
	SOFT	UM6S300304	UM6S310304	UM6S151304	UM6S150304	UM6S100304	UM6S157304	UM6S75304	UM6S37304
STATUARIO ALTISSIMO	SHINY	UM6L300441	-	-	UM6L150441	-	UM6L157441	UM6L75441	UM6L37441
	SOFT	UM6S300441	-	-	UM6S150441	-	UM6S157441	UM6S75441	UM6S37441
STATUARIO ALTISSIMO BLOCK A	SHINY	UM6L300441A	-	-	-	-	-	-	-
	SOFT	UM6S300441A	-	-	-	-	-	-	-
STATUARIO ALTISSIMO BLOCK B	SHINY	UM6L300441B	-	-	-	-	-	-	-
	SOFT	UM6S300441B	-	-	-	-	-	-	-
THASSOS	SHINY	UM6L300318	UM6L310318	UM6L151318	UM6L150318	UM6L100318	UM6L157318	UM6L75318	UM6L37318
	SOFT	UM6S300318	UM6S310318	UM6S151318	UM6S150318	UM6S100318	UM6S157318	UM6S75318	UM6S37318
TRAVERTINO SANTA CATERINA	SHINY	UM6L300431	-	-	UM6L150431	-	UM6L157431	UM6L75431	UM6L37431
	SOFT	UM6S300431	-	-	UM6S150431	-	UM6S157431	UM6S75431	UM6S37431
ZEBRINO BLACK	SHINY	UM6L300465	-	-	UM6L150465	-	UM6L157465	UM6L75465	UM6L37465
STATUARIO ULTRA	SHINY	UM6L300260	-	-	UM6L150260	-	UM6L157260	UM6L75260	UM6L37260
	SOFT	UM6S300260	-	-	UM6S150260	-	UM6S157260	UM6S75260	UM6S37260
STATUARIO ULTRA BLOCK A	SHINY	UM6L300260A	-	-	-	-	-	-	-
	SOFT	UM6S300260A	-	-	-	-	-	-	-
STATUARIO ULTRA BLOCK B	SHINY	UM6L300260B	-	-	-	-	-	-	-
	SOFT	UM6S300260B	-	-	-	-	-	-	-
ESTREMOZ	SHINY	UM6L300466	-	-	UM6L150466	-	UM6L157466	UM6L75466	UM6L37466
	SOFT	UM6S300466	-	-	UM6S150466	-	UM6S157466	UM6S75466	UM6S37466
ERAMOSIA BROWN	SHINY	UM6L300469	-	-	UM6L150469	-	UM6L157469	UM6L75469	UM6L37469
	-	-	-	-	-	-	-	-	-
ARABESCATO STATUARIO	SHINY	-	-	-	UM6L150479	-	UM6L157479	UM6L75479	UM6L37479
	SOFT	-	-	-	UM6S150479	-	UM6S157479	UM6S75479	UM6S37479
ARABESCATO STATUARIO BLOCK A	SHINY	UM6L300479A	-	-	-	-	-	-	-
	SOFT	UM6S300479A	-	-	-	-	-	-	-
ARABESCATO STATUARIO BLOCK B	SHINY	UM6L300479B	-	-	-	-	-	-	-
	SOFT	UM6S300479B	-	-	-	-	-	-	-
BIANCO COVELANO	SHINY	UM6L300480	-	-	UM6L150480	-	UM6L157480	UM6L75480	UM6L37480
	SOFT	UM6S300480	-	-	UM6S150480	-	UM6S157480	UM6S75480	UM6S37480
GRIS DE SAVOIE	SHINY	UM6L300498	-	-	UM6L150498	-	UM6L157498	UM6L75498	UM6L37498
	SOFT	UM6S300498	-	-	UM6S150498	-	UM6S157498	UM6S75498	UM6S37498
TRAVERTINO NAVONA	SHINY	UM6L300481	-	-	UM6L150481	-	UM6L157481	UM6L75481	UM6L37481
	SOFT	UM6S300481	-	-	UM6S150481	-	UM6S157481	UM6S75481	UM6S37481

**ULTRA
iCementi**

BRONZE	SOFT	UC6S300434	-	-	UC6S150434	-	UC6S157434	UC6S75434	UC6S37434
GRAPHITE	SOFT	UC6S300421	UC6S310421	UC6S151421	UC6S150421	UC6S100421	UC6S157421	UC6S75421	UC6S37421
IRON	SOFT	UC6S300422	UC6S310422	UC6S151422	UC6S150422	UC6S100422	UC6S157422	UC6S75422	UC6S37422
IVORY	SOFT	UC6S300433	UC6S310433	UC6S151433	UC6S150433	UC6S100433	UC6S157433	UC6S75433	UC6S37433
SILVER	SOFT	UC6S300420	UC6S310420	UC6S151420	UC6S150420	UC6S100420	UC6S157420	UC6S75420	UC6S37420

**ULTRA
PIETRE**

BASALTINA ANTRACITE	SOFT	-	UP6S310442	UP6S151442	-	UP6S100442	-	-	-
	PRL	-	UP6P310442	-	-	UP6P100442	-	-	-
BASALTINA GREY	SOFT	-	UP6S310443	UP6S151443	-	UP6S100443	-	-	-
	PRL	-	UP6P310443	-	-	UP6P100443	-	-	-
BASALTINA MOKA	SOFT	-	UP6S310444	UP6S151444	-	UP6S100444	-	-	-
	PRL	-	UP6P310444	-	-	UP6P100444	-	-	-
BASALTINA SAND	SOFT	-	UP6S310445	UP6S151445	-	UP6S100445	-	-	-
	PRL	-	UP6P310445	-	-	UP6P100445	-	-	-
BASALTINA WHITE	SOFT	-	UP6S310446	UP6S151446	-	UP6S100446	-	-	-
	PRL	-	UP6P310446	-	-	UP6P100446	-	-	-
AZUL BATEIG LIMESTONE	ST	-	UP6ST310461	UP6ST151461	-	UP6ST100461	-	-	-
	-	-	-	-	-	-	-	-	-
JERUSALEM LIMESTONE	ST	-	UP6ST310462	UP6ST151462	-	UP6ST100462	-	-	-
	-	-	-	-	-	-	-	-	-
SAN VICENTE LIMESTONE	ST	-	UP6ST310463	UP6ST151463	-	UP6ST100463	-	-	-
	-	-	-	-	-	-	-	-	-

ULTRA

CODICI E FORMATI / CODES AND SIZES /
ARTIKELNR. UND FORMATE / CODES ET FORMATS

PRL: Prelucidato
SO: Soft
ST: Structured
SHINY

SPESORE /
THICKNESS /
DICKE /
ÉPAISSEUR:
6 mm

FINITURA /
FINISH /
OBERFLÄCHENAUSFÜHRUNG /
FINITION

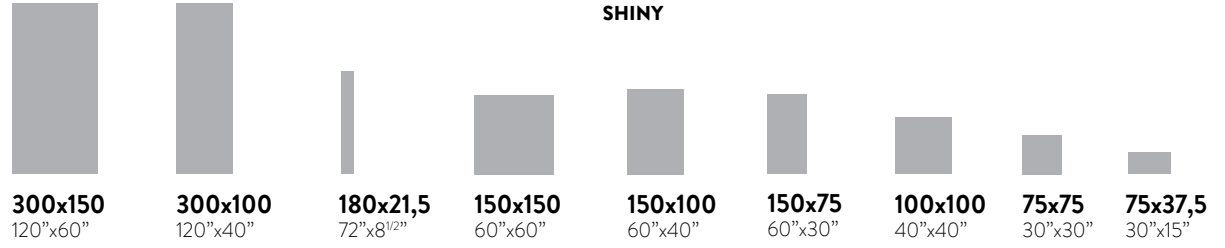

ULTRA RESINE

CALCE	PRL	-	UR6P310457	-	-	-	-	UR6P100457	-	-
	SOFT	-	UR6S310457	-	-	UR6S151457	-	UR6S100457	-	-
EBANO	PRL	-	UR6P310458	-	-	-	-	UR6P100458	-	-
	SOFT	-	UR6S310458	-	-	UR6S151458	-	UR6S100458	-	-
PIOMBO	PRL	-	UR6P310459	-	-	-	-	UR6P100459	-	-
	SOFT	-	UR6S310459	-	-	UR6S151459	-	UR6S100459	-	-
SILICIO	PRL	-	UR6P310460	-	-	-	-	UR6P100460	-	-
	SOFT	-	UR6S310460	-	-	UR6S151460	-	UR6S100460	-	-

ULTRA ONICI

BIANCO EXTRA	SHINY	UO6L300400	-	-	UO6L150400	-	UO6L157400	-	UO6L75400	UO6L37400
	SOFT	UO6S300400	-	-	UO6S150400	-	UO6S157400	-	UO6S75400	UO6S37400
BEIGE	SHINY	UO6L300401	-	-	UO6L150401	-	UO6L157401	-	UO6L75401	UO6L37401
	SOFT	UO6S300401	-	-	UO6S150401	-	UO6S157401	-	UO6S75401	UO6S37401
GRIGIO	SHINY	UO6L300411	-	-	UO6L150411	-	UO6L157411	-	UO6L75411	UO6L37411
	SOFT	UO6S300411	-	-	UO6S150411	-	UO6S157411	-	UO6S75411	UO6S37411

ULTRA WOOD

NOCE AMERICANO	SOFT	-	-	UW6S180493	-	-	-	-	-	-
NOCE CALCE	SOFT	-	-	UW6S180494	-	-	-	-	-	-
NOCE CHIARO	SOFT	-	-	UW6S180495	-	-	-	-	-	-
NOCE OSSIDATO	SOFT	-	-	UW6S180496	-	-	-	-	-	-
NOCE SCURO	SOFT	-	-	UW6S180497	-	-	-	-	-	-

ULTRA IRIDIUM

BIANCO	SHINY	UI6L300353	UI6L310353	-	UI6L150353	UI6L151353	UI6L157353	UI6L100353	UI6L75353	-
	SOFT	UI6S300353	UI6S310353	-	UI6S150353	UI6S151353	UI6S157353	UI6S100353	UI6S75353	-
GRIGIO	SHINY	UI6L300402	-	-	UI6L150402	-	UI6L157402	-	UI6L75402	-
	SOFT	UI6S300402	-	-	UI6S150402	-	UI6S157402	-	UI6S75402	-
NERO	SHINY	UI6L300357	UI6L310357	-	UI6L150357	UI6L151357	UI6L157357	UI6L100357	UI6L75357	-
	SOFT	UI6S300357	UI6S310357	-	UI6S150357	UI6S151357	UI6S157357	UI6S100357	UI6S75357	-

ULTRA

IMBALLAGGI E PESI / PACKING AND WEIGHTS / VERPACKUNG UND GEWICHT / EMBALLAGES ET POIDS

FORMATI E SPESSORI / SIZES AND THICKNESS / FORMATE UND STÄRKE / FORMATS ET ÉPAISSEUR	3000 x 150 cm 6 mm	300 x 100 cm 6 mm	180 x 21,5 x 6 mm	150 x 150 cm 6 mm	150 x 100 cm 6 mm	100 x 100 cm 6 mm	150 x 75 cm 6 mm	75 x 75 cm 6 mm	75 x 37,5 cm 6 mm
	Ultra Marmi Ultra Iridium	Ultra Marmi Ultra Pietre	Ultra Wood	Ultra Marmi Ultra Iridium	Ultra Marmi Ultra Iridium	Ultra Marmi Ultra Iridium	Ultra Marmi Ultra Iridium	Ultra Marmi Ultra Iridium	Ultra Marmi Ultra Iridium
Collezione / Collection / Kollektion / Collection	Ultra iCementi Ultra Onici	Ultra Iridium Ultra iCementi Ultra Resine		Ultra iCementi Ultra Onici	Ultra iCementi Ultra Resine Ultra Pietre	Ultra iCementi Ultra Resine Ultra Pietre	Ultra iCementi Ultra Onici	Ultra iCementi Ultra Onici	Ultra iCementi Ultra Onici
Finitura / Finish Oberflächenausführung / Finition	SHINY / SO	SHINY / SO / ST / PRL	SO	SHINY / SO	SHINY / SO / ST	SHINY / SO / ST / PRL	SHINY / SO	SHINY / SO	SHINY / SO
Pezzi Scatola / Pieces box Stücke karton / Pièces boîte	1	1	4	1	1	2	2	3	6
Mq. Scatola / Sq. Mt. Box Qm. Karton / m² boîte	4,50	3,00	1,548	2,25	1,50	2,00	2,25	1,687	1,687
Peso Scatola / Weight box Gewicht karton / Poids boîte	63,32	42,20	21,78	31,66	28,15	28,15	31,66	23,75	23,75
Peso mq. / Sq. Mt. Weight Qm. Gewicht / Poids m²	14,07	14,07	14,07	14,07	14,07	14,07	14,07	14,07	14,07
Scatole Pallet / Box Pallet Karton Palette / Boîte Palette	12	16	35	24	x	20	25	36	36
Mq. Pallet / Sq. Mt. Pallet Qm. Palette / m² Palette	54,00	48,00	54,18	54,00	x	40,00	56,25	60,77	60,77
Peso Pallet / Weight Pallet Gewicht Palette / Poids Palette	760,00	680,00	760,00	760,00	x	565,00	790,00	855,00	855,00

MARMI HIGH-TECH

CODICI E FORMATI / CODES AND SIZES /
ARTIKELNR. UND FORMATE / CODES ET FORMATS

LL: Levigato e lucidato / Honed and polished / Geschliffen und poliert / Poli et lustré
PR: Prelevigato / Prepolished / Vorgeschliffen / Prépoli

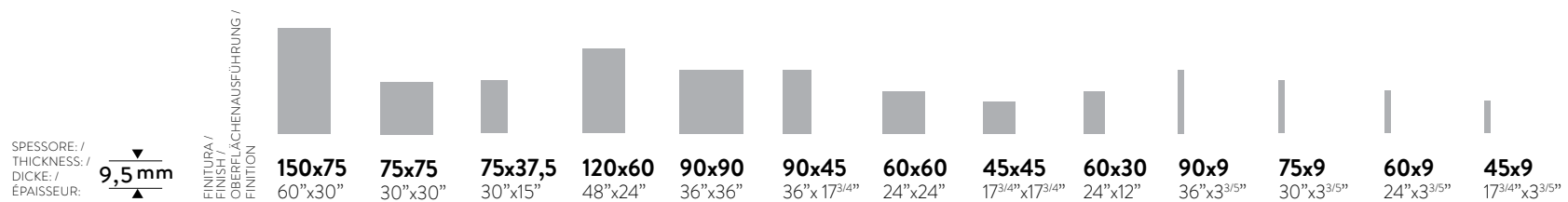

AVORIO DI SICILIA	LL	PL150381	PL75381	PL37381	-	-	-	-	-	-	-	BL75381N	-	-
	PR	P150381	P75381	P37381	-	-	-	-	-	-	-	-	-	-
BIANCO PAONAZZETTO	LL	PL150382	PL75382	PL37382	-	-	-	-	-	-	-	BL75382N	-	-
	PR	P150382	P75382	P37382	-	-	-	-	-	-	-	-	-	-
BOTTICINO	LL	-	-	-	-	-	-	PL6269	-	PL36269	-	-	BL6269N	-
	PR	-	-	-	-	-	-	P6269	-	P36269	-	-	-	-
CREMA MARFIL	LL	-	-	-	PL612304	-	PL49304	PL6304	PL45304	PL36304	BL90304N	-	BL6304N	BL45304N
	PR	-	-	-	P612304	-	P49304	P6304	P45304	P36304	-	-	-	-
DARK EMPERADOR	LL	-	-	-	PL612280	-	-	PL6280	-	PL36280	-	-	BL6280N	-
	PR	-	-	-	P612280	-	-	P6280	-	P36280	-	-	-	-
ESTREMOZ	LL	-	-	-	PL612262	-	PL49262	PL6262	PL45262	PL36262	BL90262N	-	BL6262N	BL45262N
	PR	-	-	-	P612262	-	P49262	P6262	P45262	P36262	-	-	-	-
GIALLO DI SIENA	LL	PL150419	PL75419	PL37419	-	-	-	-	-	-	-	BL75419N	-	-
	PR	-	-	-	-	-	-	-	-	-	-	-	-	-
GRIGIO DEI CARPAZI	LL	PL150383	PL75383	PL37383	-	-	-	-	-	-	-	BL75383N	-	-
	PR	P150383	P75383	P37383	-	-	-	-	-	-	-	-	-	-
NERO MARQUINIA	LL	-	-	-	-	-	-	PL6263	-	PL36263	-	-	BL6263N	-
	PR	-	-	-	-	-	-	P6263	-	P36263	-	-	-	-
NOIR ST. LAURENT	LL	PL150328	PL75328	PL37328	-	-	PL49328	PL6328	PL45328	PL36328	BL90328N	BL75328N	BL6328N	BL45328N
	PR	P150328	P75328	P37328	-	-	P49328	P6328	P45328	P36328	-	-	-	-
ROSA PORTOGALLO	LL	-	-	-	-	-	-	PL6261	-	PL36261	-	-	BL6261N	-
	PR	-	-	-	-	-	-	P6261	-	P36261	-	-	-	-
ROSSO ALICANTE	LL	PL150384	PL75384	PL37384	-	-	-	-	-	-	-	BL75384N	-	-
	PR	P150384	P75384	P37384	-	-	-	-	-	-	-	-	-	-
SKYROS	LL	-	-	-	-	-	PL49329	PL6329	PL45329	-	BL90329N	-	BL6329N	BL45329N
	PR	-	-	-	-	-	P49329	-	P45329	-	-	-	-	-
STATUARIO	LL	PL150260	PL75260	PL37260	PL612260	-	-	PL6260	-	PL36260	-	BL75260N	BL6260N	-
	PR	-	-	-	P612260	-	-	P6260	-	P36260	-	-	-	-
THASSOS	LL	PL150318	PL75318	PL37318	PL612318	PL90318	PL49318	PL6318	PL45318	-	BL90318N	BL75318N	BL6318N	BL45318N
	PR	P150318	P75318	P37318	P612318	P90318	P49318	P6318	P45318	-	-	-	-	-
TRAVERTINO NAVONA	LL	PL150281	PL75281	PL37281	PL612281	PL90281	PL49281	PL6281	PL45281	PL36281	BL90281N	BL75281N	BL6281N	BL45281N
	PR	-	-	-	P612281	P90281	P49281	P6281	P45281	P36281	-	-	-	-
VERDE ALPI	LL	-	-	-	-	-	-	PL6282	-	PL36282	-	-	BL6282N	-
	PR	-	-	-	-	-	-	P6282	-	P36282	-	-	-	-

**PEZZI SPECIALI
TRIMS /
FORMTEILE /
PIÈCES SPÉCIALES**

FINITURA /
FINISH /
OBERFLÄCHENAUSFÜHRUNG /
FINITION

BATTISCOPIA /
BULLNOSE /
STEHSOCKEL /
PLINTHE



90x9
36"x3^{3/5}"

75x9
30"x3^{3/5}"

60x9
24"x3^{3/5}"

45x9
17^{3/4}"x3^{3/5}"

GRADONE TORO /
STEP TREAD /
STUFENPLATTE /
NEZ DE MARCHE

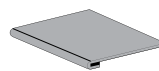

120x34
48"x13^{1/2}"

60x34
24"x13^{1/2}"

45x34
17^{3/4}"x13^{1/2}"

30x34
12"x13^{1/2}"

AVORIO DI SICILIA	LL	-	BL75381AN	-	-	-	-	-		
	PR	-	B75381T	-	-	-	-	-		
BIANCO PAONAZZETTO	LL	-	BL75382AN	-	-	-	-	-		
	PR	-	B75382T	-	-	-	-	-		
BOTTICINO	LL	-	-	BL6269AN	-	-	PGLTT60269	PGLTT30269		
	PR	-	-	B96269T	-	-	PGTT60269	PGTT30269		
CREMA MARFIL	LL	BL90304AN	-	BL6304AN	BL45304AN	-	PGLTT60304	PGLTT45304	PGLTT30304	
	PR	B90304T	-	B96304T	B45304T	-	PGTT60304	PGTT45304	PGTT30304	
DARK EMPERADOR	LL	-	-	BL6280AN	-	-	PGLTT12280	PGLTT60280	-	PGLTT30280
	PR	-	-	B96280T	-	-	PGTT12280	PGTT60280	-	PGTT30280
ESTREMOZ	LL	BL90262AN	-	BL6262AN	BL45262AN	-	PGLTT12262	PGLTT60262	PGLTT45262	PGLTT30262
	PR	B90262T	-	B96262T	B45262T	-	PGTT12262	PGTT60262	PGTT45262	PGTT30262
GIALLO DI SIENA	LL	-	BL75419AN	-	-	-	-	-	-	-
	PR	-	-	-	-	-	-	-	-	-
GRIGIO DEI CARPAZI	LL	-	BL75383AN	-	-	-	-	-	-	-
	PR	-	B75383T	-	-	-	-	-	-	-
NERO MARQUINIA	LL	-	-	BL6263AN	-	-	-	PGLTT60263	-	PGLTT30263
	PR	-	-	B96263T	-	-	-	PGTT60263	-	PGTT30263
NOIR ST. LAURENT	LL	BL90328AN	BL75328AN	BL6328AN	BL45328AN	-	-	PGLTT60328	PGLTT45328	PGLTT30328
	PR	B90328T	B75328T	B96328T	B45328T	-	-	PGTT60328	PGTT45328	PGTT30328
ROSA PORTOGALLO	LL	-	-	BL6261AN	-	-	-	PGLTT60261	-	-
	PR	-	-	B96261T	-	-	-	PGTT60261	-	-
ROSSO ALICANTE	LL	-	BL75384AN	-	-	-	-	-	-	-
	PR	-	B75384T	-	-	-	-	-	-	-
SKYROS	LL	BL90329AN	-	BL6329AN	BL45329AN	-	-	PGLTT60329	PGLTT45329	-
	PR	B90329T	-	-	B45329T	-	-	-	PGTT45329	-
STATUARIO	LL	-	BL75260AN	BL6260AN	-	-	PGLTT12260	PGLTT60260	-	PGLTT30260
	PR	-	-	B96260T	-	-	PGTT12260	PGTT60260	-	PGTT30260
THASSOS	LL	BL90318AN	BL75318AN	BL6318AN	BL45318AN	-	PGLTT12318	-	PGLTT45318	-
	PR	B90318T	B75318T	B96318T	B45318T	-	PGTT12318	-	PGTT45318	-
TRAVERTINO NAVONA	LL	BL90281AN	BL75281AN	BL6281AN	BL45281AN	-	PGLTT12281	PGLTT60281	PGLTT45281	PGLTT30281
	PR	B90281T	-	B96281T	B45281T	-	PGTT12281	PGTT60281	PGTT45281	PGTT30281
VERDE ALPI	LL	-	-	BL6282AN	-	-	-	PGLTT60282	-	PGLTT30282
	PR	-	-	B96282T	-	-	-	PGTT60282	-	PGTT30282

LL: Levigato e lucidato / Honed and polished / Geschliffen und poliert / Poli et lustré
PR: Prelevigato / Prepolished / Vorgeschliffen / Prépoli

* GRADONE E ANGOLARE COSTA RETTA 37,5 cm x ... DA 100 A 150 cm DISPONIBILE A RICHIESTA
 COSTA RETTA STEP TREAD AND CORNER 37,5 cm x ... FROM 100 TO 150 cm AVAILABLE ON DEMAND
 STUFE UND ECKSTUFE COSTA RETTA 37,5 cm x ... VON 100 BIS 150 cm AUF ANFRAGE ERHÄLTICH
 NEZ DE MARCHE ET NEZ DE MARCHE AVEC ANGLE COSTA RETTA 37,5 cm x ... DE 100 AU 150 cm DISPONIBLE SUR DEMANDE

**MOSAICI
 MOSAICS /
 MOSAIKEN /
 MOSAÏQUES**

**PEZZI SPECIALI
 TRIMS /
 FORMTEILE /
 PIÈCES SPÉCIALES**

ANGOLARE TORO / STEP TREAD CORNER / STUFENPLATTE MIT ECKE / NEZ DE MARCHE AVEC ANGLE

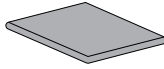

FINITURA / FINISH / OBERFLÄCHENAUSFÜHRUNG / FINITION

120x34
48"x13^{1/2}"

60x34
24"x13^{1/2}"

45x34
17^{3/4}"x13^{1/2}"

30x34
12"x13^{1/2}"

GRADONE COSTA RETTA / COSTA RETTA STEP TREAD / STUFE COSTA RETTA / NEZ DE MARCHE COSTA RETTA

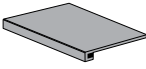

ANGOLARE COSTA RETTA / COSTA RETTA STEP TREAD CORNER / ECKSTUFE COSTA RETTA / NEZ DE MARCHE COSTA RETTA AVEC ANGLE

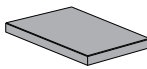

37,5x*
15"x

37,5x*
15"x

MOSAICO



30x30
12"x12"

AVORIO DI SICILIA	LL	-	-	-	-
	PR	-	-	-	-
BIANCO PAONAZZETTO	LL	-	-	-	-
	PR	-	-	-	-
BOTTICINO	LL	-	PALTT60269	-	PALTT30269
	PR	-	PATT60269	-	PATT30269
CREMA MARFIL	LL	-	PALTT60304	PALTT45304	PALTT30304
	PR	-	PATT60304	PATT45304	PATT30304
DARK EMPERADOR	LL	PALTT12280	PALTT60280	-	PALTT30280
	PR	PATT12280	PATT60280	-	PATT30280
ESTREMOZ	LL	PALTT12262	PALTT60262	PALTT45262	PALTT30262
	PR	PATT12262	PATT60262	PATT45262	PATT30262
GIALLO DI SIENA	LL	-	-	-	-
	PR	-	-	-	-
GRIGIO DEI CARPAZI	LL	-	-	-	-
	PR	-	-	-	-
NERO MARQUINIA	LL	-	PALTT60263	-	PALTT30263
	PR	-	PATT60263	-	PATT30263
NOIR ST. LAURENT	LL	-	PALTT60238	PALTT45328	PALTT30328
	PR	-	PATT60328	PATT45328	PATT30328
ROSA PORTOGALLO	LL	-	PALTT60261	-	-
	PR	-	PATT60261	-	-
ROSSO ALICANTE	LL	-	-	-	-
	PR	-	-	-	-
SKYROS	LL	-	PALTT60329	PALTT45329	-
	PR	-	-	PATT45329	-
STATUARIO	LL	PALTT12260	PALTT60260	-	PALTT30260
	PR	PATT12260	PATT60260	-	PATT30260
THASSOS	LL	PALTT12318	-	PALTT45318	-
	PR	PATT12318	-	PATT45318	-
TRAVERTINO NAVONA	LL	PALTT12281	PALTT60281	PALTT45281	PALTT30281
	PR	PATT12281	PATT60281	PATT45281	PATT30281
VERDE ALPI	LL	-	PALTT60282	-	PALTT30282
	PR	-	PATT60282	-	PATT30282

PGRL381...	PRAL381...	MOSL381
PGR381...	PRA381...	-
PGRL382...	PRAL382...	MOSL382
PGR382...	PRA382...	-
-	-	-
-	-	-
-	-	MOSL304
-	-	-
-	-	-
-	-	-
-	-	MOSL262
-	-	-
PGRL419...	PRAL419...	MOSL419
-	-	-
PGRL383...	PRAL383...	MOSL383
PGR383...	PRA383...	-
-	-	-
-	-	-
PGRL328...	PRAL328...	MOSL328
-	-	-
-	-	MOSL261
-	-	-
PGRL384...	PRAL384...	MOSL384
PGR384...	PRA384...	-
-	-	-
-	-	MOSL329
-	-	-
PGRL260...	PRAL260...	MOSL260
-	-	-
PGRL318...	PRAL318...	MOSL318
PGR318...	PRA318...	-
PGRL281...	PRAL281...	MOSL281
-	-	-
-	-	-
-	-	-

MATERIE HIGH-TECH

CODICI E FORMATI / CODES AND SIZES /
ARTIKELNR. UND FORMATE / CODES ET FORMATS

N: Naturale / Natural / Naturbelassen / Naturel
SO: Soft

SPessore: / THICKNESS: / DICKE: / ÉPAISSEUR: **8mm**

FINITURA / FINISH / OBERFLÄCHENAUSFÜHRUNG / FINITION

		150x75 60"x30"	75x75 30"x30"
CENERE	SO	PS150452	PS75452
FANGO	SO	PS150453	PS75453
GESSO	SO	PS150454	PS75454
LAVA	SO	PS150455	PS75455
SABBIA	SO	PS150456	PS75456

PEZZI SPECIALI TRIMS / FORMTEILE / PIÈCES SPÉCIALES

GRADINO CLASSICO / STEP TREAD / STUFENPLATTE / NEZ DE MARCHÉ

BATTISCOPA / BULLNOSE / STEHSCOCKEL / PLINTHE

GRADONE COSTA RETTA / COSTA RETTA STEP TREAD / STUFE COSTA RETTA / NEZ DE MARCHÉ COSTA RETTA

ANGOLARE COSTA RETTA / COSTA RETTA STEP TREAD CORNER / ECKSTUFE COSTA RETTA / NEZ DE MARCHÉ COSTA RETTA AVEC ANGLE

75x37,5 30"x15"	75x9 30"x3 ^{3/5} "	150x37,5 60"x15"	150x37,5 60"x15"
GS75452R1	BS75452T	PGRST150452	PRAST150452
GS75453R1	BS75453T	PGRST150453	PRAST150453
GS75454R1	BS75454T	PGRST150454	PRAST150454
GS75455R1	BS75455T	PGRST150455	PRAST150455
GS75456R1	BS75456T	PGRST150456	PRAST150456

SPessore: / THICKNESS: / DICKE: / ÉPAISSEUR: **10mm**

FINITURA / FINISH / OBERFLÄCHENAUSFÜHRUNG / FINITION

		120x60 48"x24"	60x60 24"x24"	60x30 24"x12"
CENERE	SO	PS612452	PS6452	PS36452
	N	P612452	P6452	P36452
FANGO	SO	PS612453	PS6453	PS36453
	N	P612453	P6453	P36453
GESSO	SO	PS612454	PS6454	PS36454
	N	P612454	P6454	P36454
LAVA	SO	PS612455	PS6455	PS36455
	N	P612455	P6455	P36455
SABBIA	SO	PS612456	PS6456	PS36456
	N	P612456	P6456	P36456
LIGNITE	SO	PS612473	PS6473	PS36473
	N	P612473	P6473	P36473
GHIACCIO	SO	PS612474	PS6474	PS36474
	N	P612474	P6474	P36474
DIORITE	SO	PS612475	PS6475	PS36475
	N	P612475	P6475	P36475
PELTRO	SO	PS612476	PS6476	PS36476
	N	P612476	P6476	P36476

PEZZI SPECIALI TRIMS / FORMTEILE / PIÈCES SPÉCIALES

GRADINO CLASSICO / STEP TREAD / STUFENPLATTE / NEZ DE MARCHÉ

BATTISCOPA / BULLNOSE / STEHSCOCKEL / PLINTHE

GRADONE COSTA RETTA / COSTA RETTA STEP TREAD / STUFE COSTA RETTA / NEZ DE MARCHÉ COSTA RETTA

ANGOLARE COSTA RETTA / COSTA RETTA STEP TREAD CORNER / ECKSTUFE COSTA RETTA / NEZ DE MARCHÉ COSTA RETTA AVEC ANGLE

60x30 24"x12"	60x9 24"x3 ^{3/5} "	120x34 48"x13 ^{1/2} "	120x34 48"x13 ^{1/2} "
GS6452R1	BS9452T	PGRST12452	PRAST12452
GR6452R1	B9452T		
GS6453R1	BS9453T	PGRST12453	PRAST12453
GR6453R1	B9453T		
GS6454R1	BS9454T	PGRST12454	PRAST12454
GR6454R1	B9454T		
GS6455R1	BS9455T	PGRST12455	PRAST12455
GR6455R1	B9455T		
GS6456R1	BS9456T	PGRST12456	PRAST12456
GR6456R1	B9456T		
GS6473R1	BS9473T	PGRST12473	PRAST12473
GR6473R1	B9473T		
GS6474R1	BS9474T	PGRST12474	PRAST12474
GR6474R1	B9474T		
GS6475R1	BS9475T	PGRST12475	PRAST12475
GR6475R1	B9475T		
GS6476R1	BS9476T	PGRST12476	PRAST12476
GR6476R1	B9476T		

SPessore: / THICKNESS: / DICKE: / ÉPAISSEUR: **20mm**

FINITURA / FINISH / OBERFLÄCHENAUSFÜHRUNG / FINITION

		120x60 48"x24"	60x60 24"x24"
CENERE	cm2	PMS612452	PMS60452
FANGO	cm2	PMS612453	PMS60453
DIORITE	cm2	PMS612475	PMS60475
PELTRO	cm2	PMS612476	PMS60476

PEZZI SPECIALI TRIMS / FORMTEILE / PIÈCES SPÉCIALES

GRADONE BECCO CM2 / STEPTREAD WITH HALF BULLNOSE EDGE / STUFENPLATTE MIT ABGERUNDETER KANTE / NEZ DE MARCHÉ AVEC BORD ARRONDÉ

GRADONE TORO CM2 / STEPTREAD GRADONE TORO CM2 / STUFENPLATTE GRADONE TORO CM2 / NEZ DE MARCHÉ ÉPAISSEUR 2CM

GRIGLIA CM2 / WATER GRATE / ABDECKPLATTE WASSERABLAUF / GRILLE

60x30 24"x12"	60x30 24"x12"	60x15 24"x6"
GMS6452B1	GMST6452	GRIGLIA452
GMS6453B1	GMST6453	GRIGLIA453
GMS6475B1	GMST6475	GRIGLIA475
GMS6476B1	GMST6476	GRIGLIA476

PIETRE NATURALI HIGH-TECH

CODICI E FORMATI / CODES AND SIZES /
ARTIKELNR. UND FORMATE / CODES ET FORMATS

AN: Anticato / Antiqued / Antik / Antique
BA: Bamboo

HH: High-Honed
N: Naturale / Natural / Naturbelassen / Naturel

	FINITURA / FINISH / OBERFLÄCHENAUSFÜHRUNG / FINITION											
		150x75 60"x30"	150x75 60"x30"	120x60 48"x24"	120x60 48"x24"	120x30 48"x12"	90x90 36"x36"	90x45 36"x17 ^{3/4} "	75x75 30"x30"	75x75 30"x30"	75x37,5 30"x15"	
SPESORE: / THICKNESS: / DICKE: / ÉPAISSEUR:	▼ 10mm ▲											
ARDESIA ANTRACITE	SL	-	-	P612390	-	-	-	-	-	-	-	
	ST	-	-	PS612390	-	-	-	-	-	-	-	
ARDESIA BORDEAUX	ST	-	-	-	-	-	-	-	-	-	-	
	HH	-	-	-	-	-	-	-	-	-	-	
BASALTO GRIGIO	ST	-	-	-	-	-	-	-	-	-	-	
BLACK ARDESIA	SA	-	-	P612330	-	-	-	-	-	-	-	
	ST	-	-	PS612277	-	-	PS90277	PS49277	-	-	-	
CADAPPA BLACK	SA	-	-	-	-	-	-	P49277	-	-	-	
	HH	-	-	-	-	-	-	-	-	-	-	
CREMA EUROPA	SL	-	-	P612391	-	-	-	-	-	-	-	
	ST	-	-	PS612391	-	-	-	-	-	-	-	
GREEN QUARZITE	ST	-	-	PS612296	-	-	-	PS49296	-	-	-	
	SA	-	-	-	-	-	-	P49296	-	-	-	
LIMRA	HH	-	-	-	-	-	-	-	-	-	-	
	ST	-	-	-	-	-	-	-	-	-	-	
PIETRA D'AVOLA	SA	-	-	P612331	-	-	P90331	P49331	-	-	-	
	N	-	-	P612428	-	P120428	-	-	-	-	-	
PIETRA DELL'ESTEREL	BA	-	-	PBB612428	-	PBB120428	-	-	-	-	-	
	ST	-	-	-	-	-	-	-	-	-	-	
PIETRA DI BARGE	ST	-	-	-	-	-	-	-	-	-	-	
	SA	-	-	-	-	-	-	-	-	-	-	
PIETRA DI BORGOGNA	ST	-	-	-	-	-	-	-	-	-	-	
	SA	-	-	-	-	-	-	P49332	-	-	-	
PIETRA DI BRUGGE	ST	PS150406	PS150406AC	-	-	-	-	-	PS75406	PS75406AC	PS37406	
	SO	P150406	-	-	-	-	-	-	P75406	-	P37406	
	AN	PSA150406	-	-	-	-	-	-	PSA75406	-	PSA37406	
PIETRA DI CALAIS	ST	PS150405	PS150405AC	-	-	-	-	-	PS75405	PS75405AC	PS37405	
	SO	P150405	-	-	-	-	-	-	P75405	-	P37405	
	AN	PSA150405	-	-	-	-	-	-	PSA75405	-	PSA37405	
PIETRA DI ESSEN	ST	PS150407	-	-	-	-	-	-	PS75407	-	PS37407	
	SO	P150407	-	-	-	-	-	-	P75407	-	P37407	
	AN	PSA150407	-	-	-	-	-	-	PSA75407	-	PSA37407	
PIETRA DI LUSERNA	ST	-	-	-	-	-	-	-	-	-	-	
	SA	-	-	-	-	-	-	-	-	-	-	
PIETRA DI MERANO	ST	-	-	-	-	-	-	-	-	-	-	
	SA	-	-	-	-	-	-	-	-	-	-	
PIETRA DI RAGUSA	ST	-	-	-	-	-	-	PS49302	-	-	-	
PIETRA DI ROUBAIX	ST	PS150409	-	-	-	-	-	-	PS75409	-	PS37409	
	SO	P150409	-	-	-	-	-	-	P75409	-	P37409	
	AN	PSA150409	-	-	-	-	-	-	PSA75409	-	PSA37409	
PIETRA DI UTRECHT	ST	PS150408	-	-	-	-	-	-	PS75408	-	PS37408	
	SO	P150408	-	-	-	-	-	-	P75408	-	P37408	
	AN	PSA150408	-	-	-	-	-	-	PSA75408	-	PSA37408	
PIETRA GIALLA	ST	-	-	-	-	-	-	-	-	-	-	
	SA	-	-	-	-	-	-	-	-	-	-	
PIETRA PIASENTINA	ST	-	-	PS612259	-	-	-	-	-	-	-	
	SA	-	-	-	-	-	-	-	-	-	-	
PIETRA SINTRA	SL	-	-	P612392	-	-	-	-	-	-	-	
	ST	-	-	PS612392	PS612392AC	-	-	-	-	-	-	
QUARZITE BIANCA	SL	-	-	P612393	-	-	-	-	-	-	-	
	ST	-	-	PS612393	PS612393AC	-	-	-	-	-	-	
SILK GEORGETTE	N	-	-	P612429	-	P120429	-	-	-	-	-	
	BA	-	-	PBB612429	-	PBB120429	-	-	-	-	-	
SILVER GREY	SL	-	-	P612394	-	-	-	-	-	-	-	
	ST	-	-	PS612394	-	-	-	-	-	-	-	
TRAVERTINO CHIARO	N	-	-	P612430	-	P120430	-	-	-	-	-	
	BA	-	-	PBB612430	-	PBB120430	-	-	-	-	-	
TRAVERTINO NOCE	N	-	-	P612468	-	P120468	-	-	-	-	-	
	BA	-	-	PBB612468	-	PBB120468	-	-	-	-	-	

SA: Satinato / Satin-finish / Satiniert / Satiné
SL: Semilucidato / Semi-polished / Semi-matt / Semi-lustré

SO: Soft
ST: Strutturato / Structured / Strukturiert / Structuré

		ACTIVE		ACTIVE								
		75x37,5 30"x15"	60x60 24"x24"	60x60 24"x24"	60x30 24"x12"	60x15 24"x6"	60x10 24"x4"	30x30 12"x12"	30x15 12"x6"	15x15 6"x6"	90x9 36"x3 ^{3/5} "	
ARDESIA ANTRACITE	SL	-	P6390	-	P36390	P615390	P610390	-	-	-	-	-
	ST	-	PS6390	-	PS36390	PS615390	PS610390	-	-	-	-	-
ARDESIA BORDEAUX	ST	-	PS6293	-	PS36293	PS615293	PS610293	PS3293	-	-	-	-
	HH	-	PHH6293	-	-	PHH615293	-	-	-	-	-	-
BASALTO GRIGIO	ST	-	PS6330	-	PS36330	PS615330	PS610330	-	-	-	-	-
	SA	-	P6330	-	P36330	P615330	P610330	-	-	-	-	-
BLACK ARDESIA	ST	-	PS6277	-	PS36277	PS615277M	PS610277	PS3277	PS315277	PS15277	BS90277N	-
	SA	-	P6277	-	P36277	P615277	P610277	P3277	P315277	P15277	B90277N	-
	HH	-	PHH6277	-	-	PHH615277	-	-	-	-	-	-
CADAPPA BLACK	SL	-	P6391	-	P36391	P615391	P610391	-	-	-	-	-
	ST	-	PS6391	-	PS36391	PS615391	PS610391	-	-	-	-	-
CREMA EUROPA	ST	-	PS6296	-	PS36296	PS615296	PS610296	PS3296	PS315296	PS15296	BS90296N	-
	SA	-	P6296	-	P36296	P615296	P610296	P3296	-	-	B90296N	-
	HH	-	PHH6296	-	-	PHH615296	-	-	-	-	-	-
GREEN QUARZITE	ST	-	PS6258	-	PS36258	PS615258	PS610258	PS3258	PS315258	PS15258	-	-
LIMRA	ST	-	PS6331	-	PS36331	PS615331	PS610331	-	-	-	-	-
	SA	-	P6331	-	P36331	P615331	P610331	-	-	-	-	-
PIETRA D'AVOLA	N	-	P6428	-	P36428	-	-	-	-	-	-	-
	BA	-	PBB6428	-	PBB36428	-	-	-	-	-	-	-
PIETRA DELL'ESTEREL	ST	-	PS6370	-	PS36370	PS615370	PS610370	-	-	-	-	-
PIETRA DI BARGE	ST	-	PS6255	-	PS36255	PS615255M	PS610255	PS3255	PS315255	PS15255	-	-
	SA	-	P6255	-	P36255	P615255	P610255	P3255	-	-	-	-
PIETRA DI BORGOGNA	ST	-	PS6332	-	PS36332	PS615332	PS610332	-	-	-	-	-
	SA	-	P6332	-	P36332	P615332	P610332	-	-	-	B90332N	-
PIETRA DI BRUGGE	ST	PS37406AC	-	-	-	-	-	-	-	-	-	-
	SO	-	-	-	-	-	-	-	-	-	-	-
	AN	-	-	-	-	-	-	-	-	-	-	-
PIETRA DI CALAIS	ST	PS37405AC	-	-	-	-	-	-	-	-	-	-
	SO	-	-	-	-	-	-	-	-	-	-	-
	AN	-	-	-	-	-	-	-	-	-	-	-
PIETRA DI ESSEN	ST	-	-	-	-	-	-	-	-	-	-	-
	SO	-	-	-	-	-	-	-	-	-	-	-
	AN	-	-	-	-	-	-	-	-	-	-	-
PIETRA DI LUSERNA	ST	-	PS6264	-	PS36264	PS615264	PS610264	PS3264	PS315264	PS15264	-	-
	SA	-	-	-	P36264	P615264	P610264	P3264	-	-	-	-
PIETRA DI MERANO	ST	-	PS6333	-	PS36333	PS615333	PS610333	-	-	-	-	-
	SA	-	P6333	-	P36333	P615333	P610333	-	-	-	-	-
PIETRA DI RAGUSA	ST	-	PS6302	-	PS36302	PS615302	PS610302	PS3302	PS315302	PS15302	BS90302N	-
PIETRA DI ROUBAIX	ST	-	-	-	-	-	-	-	-	-	-	-
	SO	-	-	-	-	-	-	-	-	-	-	-
	AN	-	-	-	-	-	-	-	-	-	-	-
PIETRA DI UTRECHT	ST	-	-	-	-	-	-	-	-	-	-	-
	SO	-	-	-	-	-	-	-	-	-	-	-
	AN	-	-	-	-	-	-	-	-	-	-	-
PIETRA GIALLA	ST	-	-	-	PS36257	PS615257	PS610257	PS3257	PS315257	PS15257	-	-
	SA	-	-	-	P36257	P615257	P610257	P3257	-	-	-	-
PIETRA PIASENTINA	ST	-	PS6259	-	PS36259	PS615259M	PS610259	PS3259	PS315259	PS15259	-	-
	SA	-	P6259	-	P36259	P615259	P610259	P3259	-	-	-	-
PIETRA SINTRA	SL	-	P6392	-	P36392	P615392	P610392	-	-	-	-	-
	ST	-	PS6392	PS6392AC	PS36392	PS615392	PS610392	-	-	-	-	-
QUARZITE BIANCA	SL	-	P6393	-	P36393	P615393	P610393	-	-	-	-	-
	ST	-	PS6393	PS6393AC	PS36393	PS615393	PS610393	-	-	-	-	-
SILK GEORGETTE	N	-	P6429	-	P36429	-	-	-	-	-	-	-
	BA	-	PBB6429	-	PBB36429	-	-	-	-	-	-	-
SILVER GREY	SL	-	P6394	-	P36394	P615394	P610394	-	-	-	-	-
	ST	-	PS6394	-	PS36394	PS615394	PS610394	-	-	-	-	-
TRAVERTINO CHIARO	N	-	P6430	-	P36430	-	-	-	-	-	-	-
	BA	-	PBB6430	-	PBB36430	-	-	-	-	-	-	-
TRAVERTINO NOCE	N	-	P6468	-	P36468	-	-	-	-	-	-	-
	BA	-	PBB6468	-	PBB36468	-	-	-	-	-	-	-

PIETRE NATURALI HIGH-TECH

AN: Anticato / Antiqued / Antik / Antique
BA: Bamboo

HH: High-Honed
N: Naturale / Natural / Naturbelassen / Naturel

**PEZZI SPECIALI
TRIMS /
FORMTEILE /
PIÈCES SPÉCIALES**

FINITURA /
FINISH /
OBERFLÄCHENAUSFÜHRUNG /
FINITION

BATTISCOPA /
BULLNOSE /
STEH-SÖCKEL /
PLINTHE



90x9
36"x3^{3/5}"

75x9
30"x3^{3/5}"

60x9
24"x3^{3/5}"

30x8
12"x3^{1/5}"

ELEMENTO A "L"/
"L" ELEMENT /
SCHENKEL /
ÉLÉMENT EN "L"

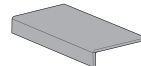

30x15
12"x6"

ELEMENTO A "L" COSTA RETTA /
COSTA RETTA "L" ELEMENT /
LÄNGSSCHENKEL
COSTA RETTA /
ÉLÉMENT EN "L" COSTA RETTA

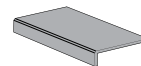

30x15
12"x6"

GRADINO CLASSICO /
STEP TREAD /
STUFENPLATTE /
NEZ DE MARCHE

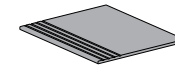

75x37,5
30"x15"

60x30
24"x12"

30x30
12"x12"

ARDESIA ANTRACITE	SL	-	-	B9390T	-	-	-	GR6390R1	-
	ST	-	-	BS9390T	-	-	-	GS6390R1	-
ARDESIA BORDEAUX	ST	-	-	BS9293T	BS8293T	PEL15293	-	GS6293R1	GS3293R1
	HH	-	-	BHH9293T	-	-	-	GHH6293R1	-
BASALTO GRIGIO	ST	-	-	BS9330T	BS8330T	PEL15330	-	GS6330R1	GS3330R1
	SA	-	-	B9330T	B8330T	-	-	GR6330R1	GR3330R1
BLACK ARDESIA	ST	BS90277T	-	BS9277T	BS8277T	PEL15277	PELR15277	GS6277R1	GS3277R1
	SA	B90277T	-	B9277T	B8277T	-	-	GR6277R1	GR3277R1
	HH	-	-	BHH9277T	-	-	-	GHH6277R1	-
CADAPPA BLACK	SL	-	-	B9391T	-	-	-	GR6391R1	-
	ST	-	-	BS9391T	-	-	-	GS6391R1	-
CREMA EUROPA	ST	BS90296T	-	BS9296T	BS8296T	PEL15296	PELR15296	GS6296R1	GS3296R1
	SA	B90296T	-	B9296T	B8296T	-	-	GR6296R1	GR3296R1
	HH	-	-	BHH9296T	-	-	-	GHH6296R1	-
GREEN QUARZITE	ST	-	-	BS9258T	BS8258T	PEL15258	PELR15258	GS6258R1	GS3258R1
LIMRA	ST	-	-	BS9331T	BS8331T	PEL15331	-	GS6331R1	GS3331R1
	SA	-	-	B9331T	B8331T	-	-	GR6331R1	GR3331R1
PIETRA D'AVOLA	N	-	-	B9428T	B8428T	-	-	GR6428R1	-
	BA	-	-	-	-	-	-	-	-
PIETRA DELL'ESTEREL	ST	-	-	BS9370T	-	-	-	GS6370R1	-
PIETRA DI BARGE	ST	-	-	BS9255T	BS8255T	PEL15255	PELR15255	GS6255R1	GS3255R1
	SA	-	-	B9255T	B8255T	-	-	GR6255R1	GR3255R1
PIETRA DI BORGOGNA	ST	-	-	BS9332T	BS8332T	PEL15332	-	GS6332R1	GS3332R1
	SA	B90332T	-	B9332T	B8332T	-	-	GR6332R1	GR3332R1
PIETRA DI BRUGGE	ST	-	BS75406T	-	-	-	-	GS75406R1	-
	SO	-	B75406T	-	-	-	-	GR75406R1	-
	AN	-	BSA75406T	-	-	-	-	GSA75406R1	-
PIETRA DI CALAIS	ST	-	BS75405T	-	-	-	-	GS75405R1	-
	SO	-	B75405T	-	-	-	-	GR75405R1	-
	AN	-	BSA75405T	-	-	-	-	GSA75405R1	-
PIETRA DI ESSEN	ST	-	BS75407T	-	-	-	-	GS75407R1	-
	SO	-	B75407T	-	-	-	-	GR75407R1	-
	AN	-	BSA75407T	-	-	-	-	GSA75407R1	-
PIETRA DI LUSERNA	ST	-	BS9264T	BS8264T	PEL15264	PELR15264	-	GS6264R1	GS3264R1
	SA	-	B9264T	B8264T	-	-	-	GR6264R1	GR3264R1
PIETRA DI MERANO	ST	-	BS9333T	BS8333T	PEL15333	-	-	GS6333R1	GS3333R1
	SA	-	B9333T	B8333T	-	-	-	GR6333R1	GR3333R1
PIETRA DI RAGUSA	ST	BS90302T	-	BS9302T	BS8302T	PEL15302	-	GS6302R1	GS3302R1
PIETRA DI ROUBAIX	ST	-	BS75409T	-	-	-	-	GS75409R1	-
	SO	-	B75409T	-	-	-	-	GR75409R1	-
	AN	-	BSA75409T	-	-	-	-	GSA75409R1	-
PIETRA DI UTRECHT	ST	-	BS75408T	-	-	-	-	GS75408R1	-
	SO	-	B75408T	-	-	-	-	GR75408R1	-
	AN	-	BSA75408T	-	-	-	-	GSA75408R1	-
PIETRA GIALLA	ST	-	BS9257T	BS8257T	PEL15257	-	-	GS6257R1	GS3257R1
	SA	-	B9257T	B8257T	-	-	-	GR6257R1	GR3257R1
PIETRA PIASENTINA	ST	-	BS9259T	BS8259T	PEL15259	PELR15259	-	GS6259R1	GS3259R1
	SA	-	B9259T	B8259T	-	-	-	GR6259R1	GR3259R1
PIETRA SINTRA	SL	-	BS9392T	-	-	-	-	GS6392R1	-
	ST	-	BS9392T	-	-	-	-	GS6392R1	-
QUARZITE BIANCA	SL	-	BS9393T	-	-	-	-	GS6393R1	-
	ST	-	BS9393T	-	-	-	-	GS6393R1	-
SILK GEORGETTE	N	-	BS9429T	B8429T	-	-	-	GR6429R1	-
	BA	-	-	-	-	-	-	-	-
SILVER GREY	SL	-	BS9394T	-	-	-	-	GS6394R1	-
	ST	-	BS9394T	-	-	-	-	GS6394R1	-
TRAVERTINO CHIARO	N	-	BS9430T	B8430T	-	-	-	GR6430T	-
	BA	-	-	-	-	-	-	-	-
TRAVERTINO NOCE	N	-	BS9468T	B8468T	-	-	-	GR6468T	-
	BA	-	-	-	-	-	-	-	-

PIETRE NATURALI HIGH-TECH

AN: Anticato / Antiqued / Antik / Antique
BA: Bamboo

HH: High-Honed
N: Naturale / Natural / Naturbelassen / Naturel

PEZZI SPECIALI TRIMS / FORMTEILE / PIÈCES SPÉCIALES

FINITURA / FINISH / OBERFLÄCHENAUFBEREITUNG / FINITION

BORDO PISCINA



75x18 **60x18**
 30"x7" 24"x7"

ANGOLO PISCINA

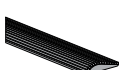

75x18 **60x18**
 30"x7" 24"x7"

MOSAICI MOSAICS / MOSAIKEN / MOSAIQUES

MOSAICO



30x30
 12"x12"

MOSAICO MODULO BRICK



30x30
 12"x12"

MOSAICO MICRO



30x30
 12"x12"

MOSAICO CLASSIC



30x30
 12"x12"

MOSAICO BLITZ



30x30
 12"x12"

ARDESIA ANTRACITE	SL	-	-	-	-
	ST	-	-	-	-
ARDESIA BORDEAUX	ST	-	-	-	-
	HH	-	-	-	-
BASALTO GRIGIO	ST	-	BRD330	-	BRDA330
	SA	-	-	-	-
BLACK ARDESIA	ST	-	BRD277	-	BRDA277
	SA	-	-	-	-
	HH	-	-	-	-
CADAPPA BLACK	SL	-	-	-	-
	ST	-	-	-	-
CREMA EUROPA	ST	-	BRD296	-	BRDA296
	SA	-	-	-	-
	HH	-	-	-	-
GREEN QUARZITE	ST	-	BRD258	-	BRDA258
LIMRA	ST	-	BRD331	-	BRDA331
	SA	-	-	-	-
PIETRA D'AVOLA	N	-	-	-	-
	BA	-	-	-	-
PIETRA DELL'ESTEREL	ST	-	-	-	-
PIETRA DI BARGE	ST	-	BRD255	-	BRDA255
	SA	-	-	-	-
PIETRA DI BORGOGNA	ST	-	-	-	-
	SA	-	-	-	-
PIETRA DI BRUGGE	ST	BRD406	-	BRDA406	-
	SO	-	-	-	-
	AN	-	-	-	-
PIETRA DI CALAIS	ST	BRD405	-	BRDA405	-
	SO	-	-	-	-
	AN	-	-	-	-
PIETRA DI ESSEN	ST	BRD407	-	BRDA407	-
	SO	-	-	-	-
	AN	-	-	-	-
PIETRA DI LUSERNA	ST	-	-	-	-
	SA	-	-	-	-
PIETRA DI MERANO	ST	-	-	-	-
	SA	-	-	-	-
PIETRA DI RAGUSA	ST	-	BRD302	-	BRDA302
PIETRA DI ROUBAIX	ST	BRD409	-	BRDA409	-
	SO	-	-	-	-
	AN	-	-	-	-
PIETRA DI UTRECHT	ST	BRD408	-	BRDA408	-
	SO	-	-	-	-
	AN	-	-	-	-
PIETRA GIALLA	ST	-	-	-	-
	SA	-	-	-	-
PIETRA PIASENTINA	ST	-	BRD259	-	BRDA259
	SA	-	-	-	-
PIETRA SINTRA	SL	-	-	-	-
	ST	-	-	-	-
QUARZITE BIANCA	SL	-	-	-	-
	ST	-	-	-	-
SILK GEORGETTE	N	-	-	-	-
	BA	-	-	-	-
SILVER GREY	SL	-	-	-	-
	ST	-	-	-	-
TRAVERTINO CHIARO	N	-	-	-	-
	BA	-	-	-	-
TRAVERTINO NOCE	N	-	-	-	-
	BA	-	-	-	-

-	MBSA390	-	-	BLISA390
-	-	-	MCST390	-
MOS293M	MBST293	-	-	-
-	-	-	-	-
MOS330M	MBST330	MIC330	MCST330	BLIST330
MOS330SM	MBSA330	-	-	BLISA330
MOS277M	MBST277	MIC277	MCST277	BLIST277
MOS277SM	MBSA277	-	-	-
-	-	-	-	-
-	MBSA391	-	-	BLISA391
-	-	-	MCST391	-
MOS296M	MBST296	MIC296	MCST296	BLIST296
MOS296SM	MBSA296	-	-	-
-	-	-	-	-
MOS258M	MBST258	MIC258	MCST258	BLIST258
MOS331M	MBST331	MIC331	MCST331	BLIST331
MOS331SM	MBSA331	-	-	BLISA331
-	-	-	-	-
-	MBST370	-	-	-
MOS255M	MBST255	MIC255	MCST255	BLIST255
MOS255SM	MBSA255	-	-	-
MOS332M	MBST332	MIC332	MCST332	BLIST332
MOS332SM	MBSA332	-	-	BLISA332
-	-	-	-	-
-	-	-	MCS406	-
-	-	-	MCSA406	-
-	-	-	-	-
-	-	-	MCS405	-
-	-	-	MCSA405	-
-	-	-	-	-
-	-	-	MCS407	-
-	-	-	MCSA407	-
MOS264M	MBST264	MIC264	MCST264	BLIST264
MOS264SM	MBSA264	-	-	-
MOS333M	MBST333	MIC333	MCST333	BLIST333
MOS333SM	MBSA333	-	-	BLISA333
-	MBST302	-	-	-
-	-	-	-	-
-	-	-	MCS409	-
-	-	-	MCSA409	-
-	-	-	-	-
-	-	-	MCS408	-
-	-	-	MCSA408	-
MOS257M	MBST257	-	-	BLIST257
MOS257SM	MBSA257	-	-	-
MOS259M	MBST259	MIC259	MCST259	BLIST259
MOS259SM	MBSA259	-	-	-
-	MBSA392	-	-	BLISA392
-	-	-	MCST392	-
-	-	-	-	-
-	MBSA393	-	-	BLISA393
-	-	-	MCST393	-
-	-	-	-	-
-	MBSA394	-	-	BLISA394
-	-	-	MCST394	-
-	-	-	-	-
-	-	-	-	-
-	-	-	-	-

SA: Satinato / Satin-finish / Satiniert / Satiné
SL: Semilucidato / Semi-polished / Semi-matt / Semi-lustré

SO: Soft
ST: Strutturato / Structured / Strukturiert / Structuré

**MOSAICI
MOSAICS /
MOSAIKEN /
MOSAÏQUES**

FINITURA /
FINISH /
OBERFLÄCHENAUSFUHRUNG /
FINITION

MODULO
RANDOM



60x30
24"x12"

MODULO
MAXI RANDOM



75x25
30"x9^{3/4}"

PALLADIANA



6 mq

ARDESIA ANTRACITE	SL	-	-	-
	ST	MRST390	-	-
ARDESIA BORDEAUX	ST	-	-	-
	HH	-	-	-
BASALTO GRIGIO	ST	-	-	-
	SA	-	-	-
BLACK ARDESIA	ST	MRST277	-	-
	SA	-	-	-
	HH	-	-	-
CADAPPA BLACK	SL	-	-	-
	ST	MRST391	-	-
CREMA EUROPA	ST	MRST296	-	-
	SA	-	-	-
	HH	-	-	-
GREEN QUARZITE	ST	MRST258	-	PALL258
LIMRA	ST	-	-	-
	SA	-	-	-
PIETRA D'AVOLA	N	-	-	-
	BA	-	-	-
PIETRA DELL'ESTEREL	ST	MRST370	-	-
PIETRA DI BARGE	ST	MRST255	-	-
	SA	-	-	-
PIETRA DI BORGOGNA	ST	MRST332	-	-
	SA	-	-	-
PIETRA DI BRUGGE	ST	-	MMRST406	-
	SO	-	-	-
	AN	-	-	-
PIETRA DI CALAIS	ST	-	MMRST405	-
	SO	-	-	-
	AN	-	-	-
PIETRA DI ESSEN	ST	-	MMRST407	-
	SO	-	-	-
	AN	-	-	-
PIETRA DI LUSERNA	ST	MRST264	-	PALL264
	SA	-	-	-
PIETRA DI MERANO	ST	MRST333	-	-
	SA	-	-	-
PIETRA DI RAGUSA	ST	MRST302	-	-
PIETRA DI ROUBAIX	ST	-	MMRST409	-
	SO	-	-	-
	AN	-	-	-
PIETRA DI UTRECHT	ST	-	MMRST408	-
	SO	-	-	-
	AN	-	-	-
PIETRA GIALLA	ST	MRST257	-	-
	SA	-	-	-
PIETRA PIASENTINA	ST	MRST259	-	-
	SA	-	-	-
PIETRA SINTRA	SL	-	-	-
	ST	MRST392	-	-
QUARZITE BIANCA	SL	-	-	-
	ST	MRST393	-	-
SILK GEORGETTE	N	-	-	-
	BA	-	-	-
SILVER GREY	SL	-	-	-
	ST	MRST394	-	-
TRAVERTINO CHIARO	N	-	-	-
	BA	-	-	-
TRAVERTINO NOCE	N	-	-	-
	BA	-	-	-

INNOVATIVE SLABS LEGNI HIGH-TECH

CODICI E FORMATI / CODES AND SIZES /
ARTIKELNR. UND FORMATE / CODES ET FORMATS

AN: Anticato / Antiqued / Antik / Antique

SPESSORE: / THICKNESS: / DICKE: / ÉPAISSEUR:	FINITURA / FINISH / OBERFLÄCHENAUFHHRUNG / FINITION	150x37,5 60"x15"			150x25 60"x10"			150x18,7 60"x8"			
		75x6,5 30"x2 ^{1/2} "			150x37,5 60"x15"			75x37,5 30"x15"			
8mm		QUERCIA BIANCA	AN	PAR37448	PAR25448	PAR18448	BA75448T	PGRA150448	PGRA75448	PRAA150448	PRAA75448
		QUERCIA PETRAEA	AN	PAR37449	PAR25449	PAR18449	BA75449T	PGRA150449	PGRA75449	PRAA150449	PRAA75449
		QUERCIA TROPICALE	AN	PAR37450	PAR25450	PAR18450	BA75450T	PGRA150450	PGRA75450	PRAA150450	PRAA75450
		QUERCIA CANADESE	AN	PAR37482	PAR25482	PAR18482	BA75482T	PGRA150482	PGRA75482	PRAA150482	PRAA75482
		QUERCIA SHABBY	AN	PAR37483	PAR25483	PAR18483	BA75483T	PGRA150483	PGRA75483	PRAA150483	PRAA75483

LEGNI HIGH-TECH

CODICI E FORMATI / CODES AND SIZES /
ARTIKELNR. UND FORMATE / CODES ET FORMATS

SPESSORE: / THICKNESS: / DICKE: / ÉPAISSEUR:	FINITURA / FINISH / OBERFLÄCHENAUFHHRUNG / FINITION	120x30 48"x12"		120x20 48"x8"		120x15 48"x6"		60x10 24"x4"		90x22,5 36"x9"		90x15 36"x6"		90x11 36"x4 ^{1/2} "	
		10mm		ROVERE ABBAZIA	AN	-	-	-	-	PAR22364	PAR15364	PAR11364			
		ROVERE ANTICO	AN	-	-	-	-	PAR22334	PAR15334	PAR11334					
		ROVERE BIANCO	AN	-	-	-	-	PAR22342	PAR15342	PAR11342					
		ROVERE BIANCO ACTIVE	AN	-	-	-	-	PAR22342AC	PAR15342AC	PAR11342AC					
		ROVERE BIONDO	AN	-	-	-	-	PAR22322	PAR15322	PAR11322					
		ROVERE BIONDO ACTIVE	AN	-	-	-	-	PAR22322AC	PAR15322AC	PAR11322AC					
		ROVERE BRICCOLA	AN	PAR30425	PAR20425	PAR115425	PAR10425								
		ROVERE CENERE	AN	PAR30397	PAR20397	PAR115397	PAR10397	-	-	-					
		ROVERE CILIEGIO	AN	-	-	-	-	PAR22336	PAR15336	PAR11336					
		ROVERE CORDA	AN	PAR30379	PAR20379	PAR115379	PAR10379	-	-	-					
		ROVERE CORDA ACTIVE	AN	PAR30379AC	PAR20379AC	PAR115379AC	-	-	-	-					
		ROVERE COUNTRY	AN	PAR30426	PAR20426	PAR115426	PAR10426	-	-	-					
		ROVERE DECAPÈ	AN	PAR30389	PAR20389	PAR115389	PAR10389	-	-	-					
		ROVERE GRIGIO	AN	-	-	-	-	PAR22335	PAR15335	PAR11335					
		ROVERE GRIGIO ACTIVE	AN	-	-	-	-	PAR22335AC	PAR15335AC	PAR11335AC					
		ROVERE IMPERO	AN	PAR30386	PAR20386	PAR115386	PAR10386	-	-	-					
		ROVERE MOKA	AN	-	-	-	-	PAR22323	PAR15323	PAR11323					
		ROVERE MOKA ACTIVE	AN	-	-	-	-	PAR22323AC	PAR15323AC	PAR11323AC					
		ROVERE NATURALE	AN	-	-	-	-	PAR22365	PAR15365	PAR11365					
		ROVERE NATURALE ACTIVE	AN	-	-	-	-	PAR22365AC	PAR15365AC	PAR11365AC					
		ROVERE NERO	AN	-	-	-	-	PAR22320	PAR15320	PAR11320					
		ROVERE NOCE	AN	PAR30395	PAR20395	PAR115395	PAR10395	-	-	-					
		ROVERE PROVENZALE	AN	PAR30424	PAR20424	PAR115424	PAR10424	-	-	-					
		ROVERE REALE	AN	PAR30387	PAR20387	PAR115387	PAR10387	-	-	-					
		ROVERE SABBIA	AN	PAR30396	PAR20396	PAR115396	PAR10396	-	-	-					
		ROVERE TUNDRA	AN	PAR30380	PAR20380	PAR115380	PAR10380	-	-	-					

**PEZZI SPECIALI
TRIMS /
FORMTEILE /
PIÈCES SPÉCIALES**

FINITURA /
FINISH /
OBERFLÄCHENAUFÜHRUNG /
FINITION

BATTISCOPA /
BULLNOSE /
STEHSOCKEL /
PLINTHE



90x9
36"x3^{3/5}"

60x9
24"x3^{3/5}"

GRADONE COSTA RETTA /
COSTA RETTA STEP TREAD /
STUFE COSTA RETTA /
NEZ DE MARCHE COSTA RETTA

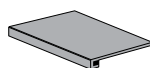

120x34
48"x13^{1/2}"

90x34
36"x13^{1/2}"

45x34
17^{3/4}"x13^{1/2}"

ANGOLARE COSTA RETTA /
COSTA RETTA STEP TREAD CORNER /
ECKSTUFE COSTA RETTA /
NEZ DE MARCHE COSTA RETTA AVEC ANGLE

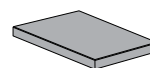

120x34
48"x13^{1/2}"

90x34
36"x13^{1/2}"

45x34
17^{3/4}"x13^{1/2}"

ROVERE ABBAZIA	AN	BA90364T	-	-	PGRA90364	PGRA45364	-	PRAA90364	PRAA45364
ROVERE ANTICO	AN	BA90334T	-	-	PGRA90334	PGRA45334	-	PRAA90334	PRAA45334
ROVERE BIANCO	AN	BA90342T	-	-	PGRA90342	PGRA45342	-	PRAA90342	PRAA45342
ROVERE BIONDO	AN	BA90322T	-	-	PGRA90322	PGRA45322	-	PRAA90322	PRAA45322
ROVERE BRICCOLA	AN	-	BA9425T	PGRA12425	-	-	PRAA12425	-	-
ROVERE CENERE	AN	-	BA9397T	PGRA12397	-	-	PRAA12397	-	-
ROVERE CILIEGIO	AN	BA90336T	-	-	PGRA90336	PGRA45336	-	PRAA90336	PRAA45336
ROVERE CORDA	AN	-	BA9379T	PGRA12379	-	-	PRAA12379	-	-
ROVERE COUNTRY	AN	-	BA9426T	PGRA12426	-	-	PRAA12426	-	-
ROVERE DECAPÈ	AN	-	BA9389T	PGRA12389	-	-	PRAA12389	-	-
ROVERE GRIGIO	AN	BA90335T	-	-	PGRA90335	PGRA45335	-	PRAA90335	PRAA45335
ROVERE IMPERO	AN	-	BA9386T	PGRA12386	-	-	PRAA12386	-	-
ROVERE MOKA	AN	BA90323T	-	-	PGRA90323	PGRA45323	-	PRAA90323	PRAA45323
ROVERE NATURALE	AN	BA90365T	-	-	PGRA90365	PGRA45365	-	PRAA90365	PRAA45365
ROVERE NERO	AN	BA90320T	-	-	PGRA90320	PGRA45320	-	PRAA90320	PRAA45320
ROVERE NOCE	AN	-	BA9395T	PGRA12395	-	-	PRAA12395	-	-
ROVERE PROVENZALE	AN	-	BA9424T	PGRA12424	-	-	PRAA12424	-	-
ROVERE REALE	AN	-	BA9387T	PGRA12387	-	-	PRAA12387	-	-
ROVERE SABBIA	AN	-	BA9396T	PGRA12396	-	-	PRAA12396	-	-
ROVERE TUNDRA	AN	-	BA9380T	PGRA12380	-	-	PRAA12380	-	-

**MOSAICI
MOSAICS /
MOSAÏKEN /
MOSAÏQUES**

MULTILAMA



30x15
12"x6"

CLASSIC



30x30
12"x12"

DOMINO



30x30
12"x12"

MAXILAMA



90x22,5
36"x9"

ROVERE ABBAZIA	AN	LAM15364	MC364	DOM364	LAM22364
ROVERE ANTICO	AN	LAM15334	MC334	DOM334	LAM22334
ROVERE BIANCO	AN	LAM15342	MC342	DOM342	LAM22342
ROVERE BIONDO	AN	LAM15322	MC322	DOM322	LAM22322
ROVERE BRICCOLA	AN	LAM15425	MC425	DOM425	-
ROVERE CENERE	AN	LAM15397	MC397	DOM397	-
ROVERE CILIEGIO	AN	LAM15336	MC336	DOM336	LAM22336
ROVERE CORDA	AN	LAM15379	MC379	DOM379	-
ROVERE COUNTRY	AN	LAM15426	MC426	DOM426	-
ROVERE DECAPÈ	AN	LAM15389	MC389	DOM389	-
ROVERE GRIGIO	AN	LAM15335	MC335	DOM335	LAM22335
ROVERE IMPERO	AN	LAM15386	MC386	DOM386	-
ROVERE MOKA	AN	LAM15323	MC323	DOM323	LAM22323
ROVERE NATURALE	AN	LAM15365	MC365	DOM365	LAM22365
ROVERE NERO	AN	LAM15320	MC320	DOM320	LAM22320
ROVERE NOCE	AN	LAM15395	MC395	DOM395	-
ROVERE PROVENZALE	AN	LAM15424	MC424	DOM424	-
ROVERE REALE	AN	LAM15387	MC387	DOM387	-
ROVERE SABBIA	AN	LAM15396	MC396	DOM396	-
ROVERE TUNDRA	AN	LAM15380	MC380	DOM380	-

WOODDRAW

CODICI E FORMATI / CODES AND SIZES /
ARTIKELNR. UND FORMATE / CODES ET FORMATS

WOODDRAW

SPESSORE: /
THICKNESS: /
DICKE: /
ÉPAISSEUR:

8 mm

FINITURA /
FINISH /
OBERFLÄCHENAUFÜHRUNG /
FINITION

120x20
48"x8"

ARTIC	AN	PAR20488
ASH	AN	PAR20489
BOARD	AN	PAR20490
POWDER	AN	PAR20491
RUST	AN	PAR20492

IRIDIUM

CODICI E FORMATI / CODES AND SIZES /
ARTIKELNR. UND FORMATE / CODES ET FORMATS

SPESORE: / THICKNESS: / DICKE: / ÉPAISSEUR: **10mm**

FINITURA / FINISH / OBERFLÄCHENAUFÜHRUNG / FINITION

60x60 24"x24"
60x30 24"x12"
60x9 24"x3^{3/5}"

ARANCIO	LL	PL6351	PL36351	BL6351N
	SO	P6351	P36351	B6351N
BIANCO	LL	PL6353	PL36353	BL6353N
	SO	P6353	P36353	B6353N
BLU	LL	PL6354	PL36354	BL6354N
	SO	P6354	P36354	B6354N
BROWN	LL	PL6356	PL36356	BL6356N
	SO	P6356	P36356	B6356N
CHAMPAGNE	LL	PL6359	PL36359	BL6359N
	SO	P6359	P36359	B6359N
GIALLO	LL	PL6355	PL36355	BL6355N
	SO	P6355	P36355	B6355N
GRIGIO	LL	PL6402	PL36402	BL6402N
	SO	P6402	P36402	B6402N
NERO	LL	PL6357	PL36357	BL6357N
	SO	P6357	P36357	B6357N
ROSSO	LL	PL6360	PL36360	BL6360N
	SO	P6360	P36360	B6360N
SKY	LL	PL6352	PL36352	BL6352N
	SO	P6352	P36352	B6352N
VERDE	LL	PL6361	PL36361	BL6361N
	SO	P6361	P36361	B6361N
VIOLET	LL	PL6362	PL36362	BL6362N
	SO	P6362	P36362	B6362N

BC: Boccardato / Bushhammered / Gestockt / Bouchardé
HH: High-Honed
LL: Levigato e lucidato / Honed and polished / Geschliffen und poliert / Poli et lustré
SA: Satinato / Satin-finish / Satiniert / Satiné
SO: Soft

BATTISCOPA / BULLNOSE / STEHSOCKEL / PLINTHE

MOSAICO

PEZZI SPECIALI TRIMS / FORMTEILE / PIÈCES SPÉCIALES

60x9 24"x3^{3/5}"

MOSAICI MOSAICS / MOSAIKEN / MOSAÏQUES

30x30 12"x12"

	LL	BL6351AN	MOSL351
	SO	B6351T	-
	LL	BL6353AN	MOSL353
	SO	B6353T	-
	LL	BL6354AN	MOSL354
	SO	B6354T	-
	LL	BL6356AN	MOSL356
	SO	B6356T	-
	LL	BL6359AN	MOSL359
	SO	B6359T	-
	LL	BL6355AN	MOSL355
	SO	B6355T	-
	LL	BL6402AN	MOSL402
	SO	B6402T	-
	LL	BL6357AN	MOSL357
	SO	B6357T	-
	LL	BL6360AN	MOSL360
	SO	B6360T	-
	LL	BL6352AN	MOSL352
	SO	B6352T	-
	LL	BL6361AN	MOSL361
	SO	B6361T	-
	LL	BL6362AN	MOSL362
	SO	B6362T	-

UNIVERSE

CODICI E FORMATI / CODES AND SIZES /
ARTIKELNR. UND FORMATE / CODES ET FORMATS

SPESORE: / THICKNESS: / DICKE: / ÉPAISSEUR: **9mm**

FINITURA / FINISH / OBERFLÄCHENAUFÜHRUNG / FINITION

60x60 24"x24"
60x30 24"x12"
60x15 24"x6"
60x10 24"x4"

BROWN	SA	P6309	P36309	P615309	P610309
	HH	LP6309	LP36309	-	-
	BC	PB6309	PB36309	-	-
CREAM	SA	P6310	P36310	P615310	P610310
	HH	LP6310	LP36310	-	-
	BC	PB6310	PB36310	-	-
HONEY	SA	P6311	P36311	P615311	P610311
	HH	LP6311	LP36311	-	-
	BC	PB6311	PB36311	-	-
MIST GREY	SA	P6312	P36312	P615312	P610312
	HH	LP6312	LP36312	-	-
	BC	PB6312	PB36312	-	-
NIGHT BLUE	SA	P6313	P36313	P615313	P610313
	HH	LP6313	LP36313	-	-
	BC	PB6313	PB36313	-	-
OBSIDIAN	SA	P6341	P36341	P615341	P610341
	HH	LP6341	LP36341	-	-
	BC	-	PB36341	-	-

BATTISCOPA / BULLNOSE / STEHSOCKEL / PLINTHE

GRADONE CLASSICO / STEP TREAD / STUFENPLATTE / NEZ DE MARCHE

GRADONE COSTA RETTA / COSTA RETTA / STEP TREAD / CORNER / ECKESTUFE / COSTA RETTA / NEZ DE MARCHE / COSTA RETTA / AVEC ANGLE

MOSAICO MODULO BRICK

PEZZI SPECIALI TRIMS / FORMTEILE / PIÈCES SPÉCIALES

60x9 24"x3^{3/5}"
30x30 12"x12"
30x34 12"x13^{1/2}"
30x34 12"x13^{1/2}"
30x30 12"x12"

MOSAICI MOSAICS / MOSAIKEN / MOSAÏQUES

	B96309T	GR3309R1	PGRSA30309	PRASA30309	MBSA309
	-	-	-	-	-
	B96310T	GR3310R1	PGRSA30310	PRASA30310	MBSA310
	-	-	-	-	-
	B96311T	GR3311R1	PGRSA30311	PRASA30311	MBSA311
	-	-	-	-	-
	B96312T	GR3312R1	PGRSA30312	PRASA30312	MBSA312
	-	-	-	-	-
	B96313T	GR3313R1	PGRSA30313	PRASA30313	MBSA313
	-	-	-	-	-
	B96341T	GR3341R1	PGRSA30341	PRASA30341	MBSA341
	-	-	-	-	-

TECNOPORCELAIN STARDUST

CODICI E FORMATI / CODES AND SIZES /
ARTIKELNR. UND FORMATE / CODES ET FORMATS

AN: Anticato / Antiqued / Antik / Antique
LL: Levigato e lucidato / Honed and polished / Geschliffen und poliert / Poli et lustré
PR: Prelevigato / Prepolished / Vorgeschliffen / Prépoli
ST: Strutturato / Structured / Strukturiert / Structuré

SPESSORE: / THICKNESS: / DICKE: / ÉPAISSEUR:	FINITURA / FINISH / OBERFLÄCHEN- AUSFÜHRUNG / FINITION	FINITURA / FINISH / OBERFLÄCHEN- AUSFÜHRUNG / FINITION				
		40x40 16"x16"	30x30 12"x12"	40x9 16"x3 ^{3/5} "	30x9 12"x3 ^{3/5} "	9x9 3 ^{3/5} "x3 ^{3/5} "
ARGENTÉ	LL - PR -	- -	PL3199 P3199C	- -	BL3199N	TL9199N
BRIQUE	LL - PR -	- -	PL3198 P3198C	- -	BL3198N	TL9198N
COBALT	LL - PR -	- -	PL3276 P3276C	- -	BL3276N	TL9276N
FUME'	LL - PR -	- -	PL3200 P3200C	- -	BL3200N	TL9200N
NOIR	LL -	PL4219	PL3219	BL4219N	BL3219N	TL9219N
PASTEL	LL -	-	PL3197	-	BL3197N	TL9197N
SABLE	LL - PR -	- -	PL3201 P3201C	- -	BL3201N	TL9201N

PEZZI SPECIALI TRIMS / FORMTEILE / PIÈCES SPÉCIALES

BATTISCOPA /
BULLNOSE /
STEHSOCKEL /
PLINTHE



40x9
16"x3^{3/5}"

30x9
12"x3^{3/5}"

30x8
12"x3^{1/5}"

GRADINO CLASSICO /
STEP TREAD /
STUFENPLATTE /
NEZ DE MARCHÉ

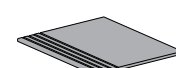

40x40
16"x16"

30x30
12"x12"

ARGENTÉ	-	BL3199AN	-	-	GL3199R1
	-	-	B8199T	-	GR3199R1
BRIQUE	-	BL3198AN	-	-	GL3198R1
	-	-	B8198T	-	GR3198R1
COBALT	-	BL3276AN	-	-	GL3276R1
	-	-	B8276T	-	GR3276R1
FUME'	-	BL3200AN	-	-	GL3200R1
	-	-	B8200T	-	GR3200R1
NOIR	BL4219AN	BL3219AN	-	-	GL4219R1
PASTEL	-	BL3197AN	-	-	GL3197R1
SABLE	-	BL3201AN	-	-	GL3201R1
	-	-	B8201T	-	GR3201R1

CM2 ARIOSTEA HIGH-TECH

CODICI E FORMATI / CODES AND SIZES /
ARTIKELNR. UND FORMATE / CODES ET FORMATS

SPESSORE: / THICKNESS: / DICKE: / ÉPAISSEUR:	FINITURA / FINISH / OBERFLÄCHEN- AUSFÜHRUNG / FINITION	FINITURA / FINISH / OBERFLÄCHEN- AUSFÜHRUNG / FINITION		
		120x60 48"x24"	120x30 48"x12"	60x60 24"x24"
CREMA EUROPA	ST -	-	-	PMS60296
GREEN QUARZITE	ST -	-	-	PMS60258
PIETRA DI RAGUSA	ST -	-	-	PMS60302
PIETRA PIASENTINA	ST -	-	-	PMS60259
BASALTO GRIGIO	ST -	-	-	PMS60330
ABSOLUTE BLACK	ST	PMS612413	-	PMS60413
GREY STONE	ST	PMS612451	-	PMS60451
ROVERE BRICCOLA	AN	PMA612425	PMA30425	-
ROVERE CENERE	AN	PMA612397	PMA30397	-
ROVERE GRIGIO	AN	PMA612335	PMA30335	-
ROVERE IMPERO	AN	PMA612386	PMA30386	-
ROVERE SABBIA	AN	PMA612396	PMA30396	-
ROVERE TUNDRA	AN	PMA612380	PMA30380	-
FANGO	cm2	PMS612453	-	PMS60453
CENERE	cm2	PMS612452	-	PMS60452
DIORITE	cm2	PMS612475	-	PMS60475
PELTRO	cm2	PMS612476	-	PMS60476

PEZZI SPECIALI TRIMS / FORMTEILE / PIÈCES SPÉCIALES

GRADONE BECCO CM2
STEP TREAD WITH HALF
BULLNOSE EDGE /
STUFENPLATTE MIT
ABGERUNDETER KANTE /
NEZ DE MARCHÉ AVEC BORD
ARRONDI

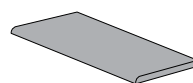

60x30
24"x12"

GRADONE TORO CM2
STEP TREAD GRADONE
TORO CM2 /
STUFENPLATTE GRADONE
TORO CM2 /
NEZ DE MARCHÉ
ÉPAISSEUR 2CM

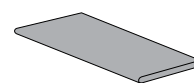

60x30
24"x12"

GRIGLIA CM2
WATER GRATE /
ABDECKPLATTE WASSERABLAUF /
GRILLE

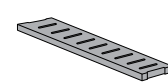

60x15
24"x6"

GMS6296B1	GMST6296	GRIGLIA296
GMS6258B1	GMST6258	GRIGLIA258
GMS6302B1	GMST6302	GRIGLIA302
GMS6259B1	GMST6259	GRIGLIA259
GMS6330B1	GMST6330	GRIGLIA330
GMS6413B1	GMST6413	GRIGLIA413
GMS6451B1	GMST6451	GRIGLIA451
-	-	-
-	-	-
-	-	-
-	-	-
-	-	-
GMS6453B1	GMST6453	GRIGLIA453
GMS6452B1	GMST6452	GRIGLIA452
GMS6475B1	GMST6475	GRIGLIA475
GMS6476B1	GMST6476	GRIGLIA476

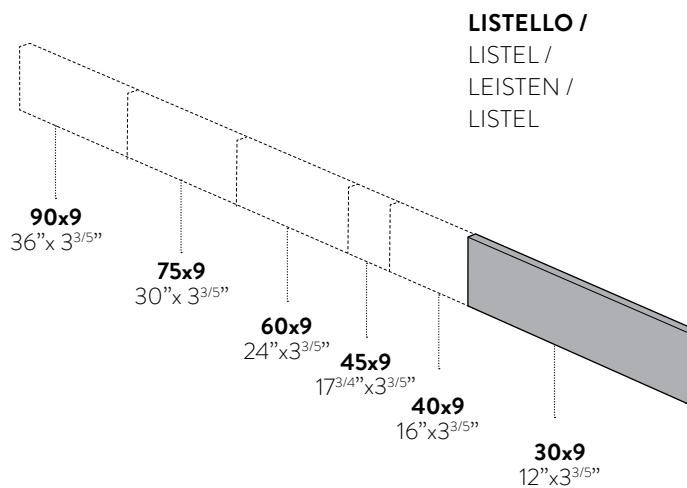
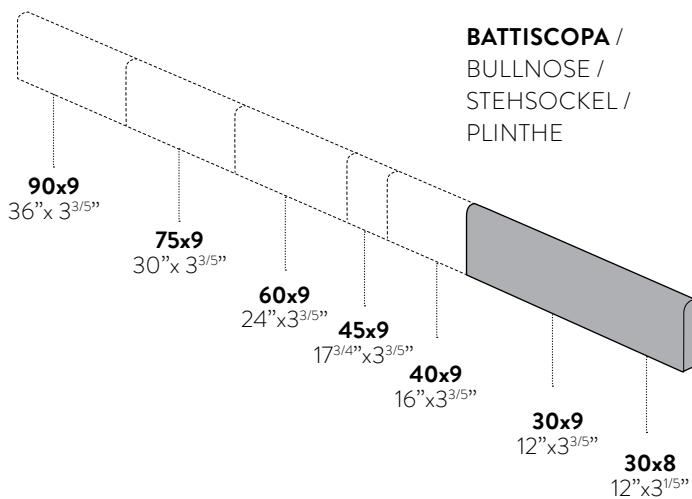
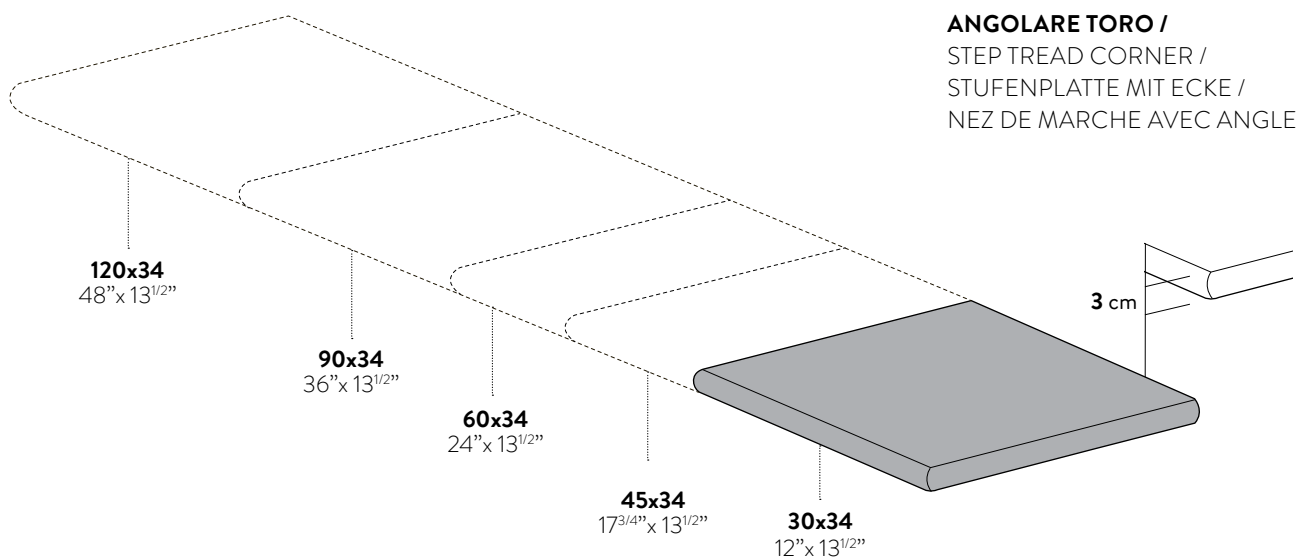
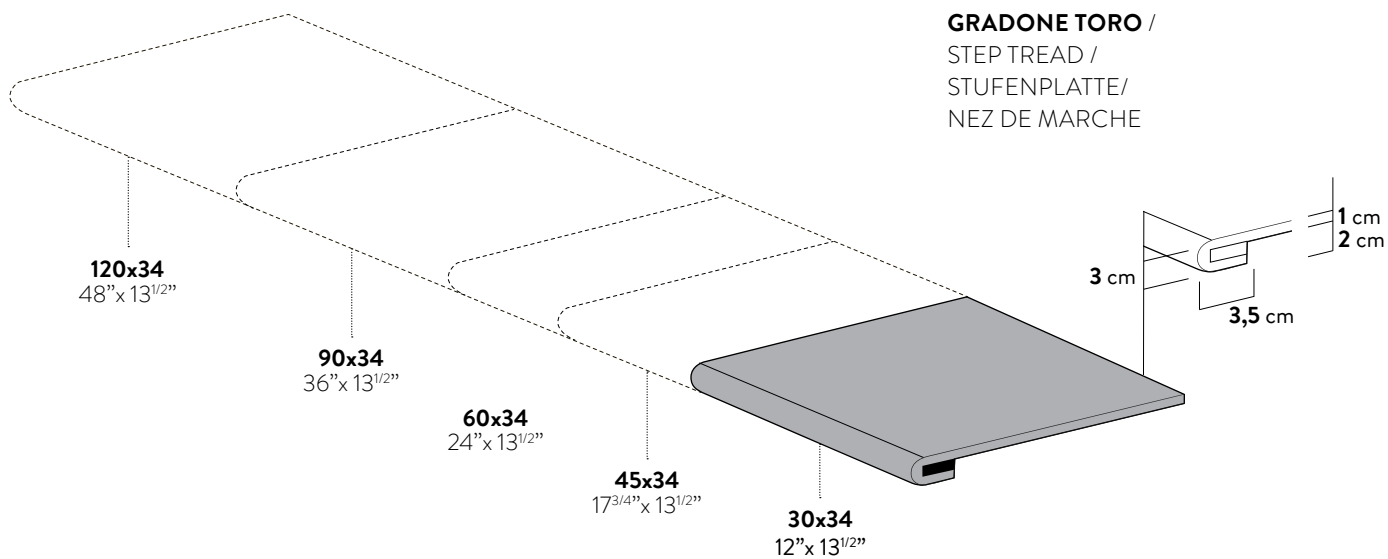

ANGOLARE COSTA RETTA /
COSTA RETTA STEP TREAD CORNER /
ECKESTUFE COSTA RETTA /
NEZ DE MARCHE COSTA RETTA
AVEC ANGLE

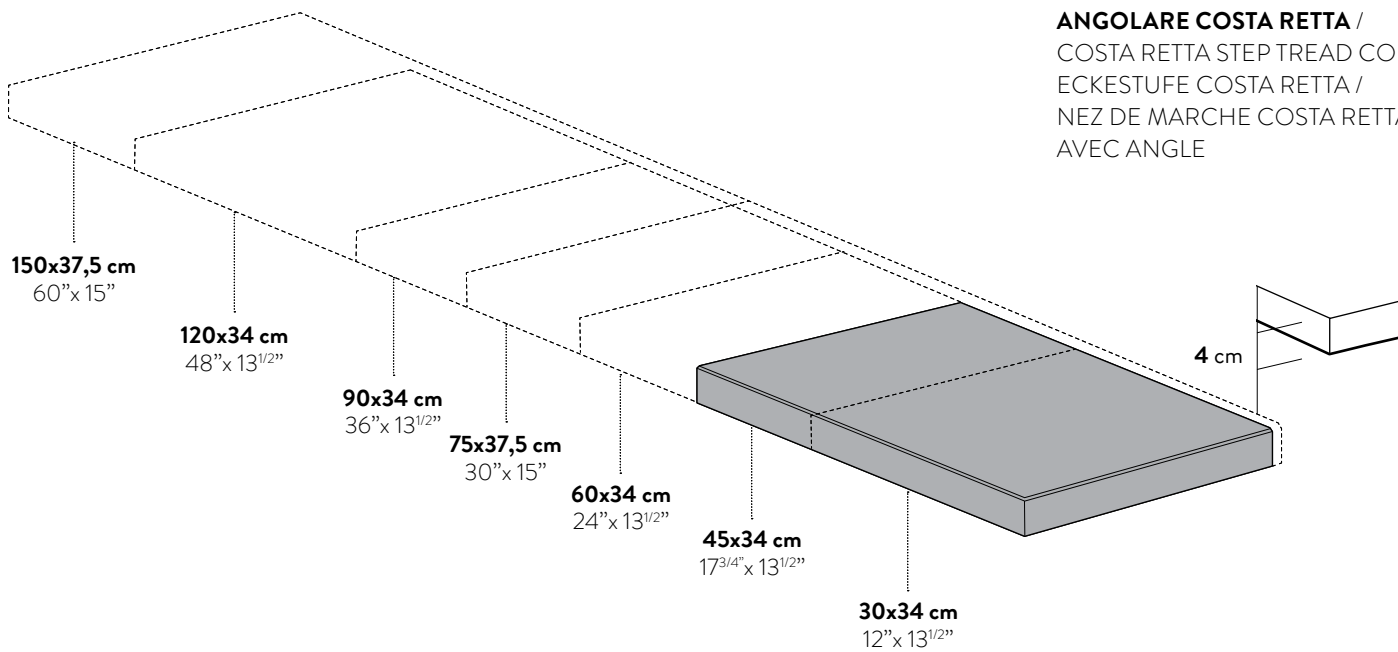

GRADONE COSTA RETTA /
COSTA RETTA STEP TREAD /
STUFE COSTA RETTA /
NEZ DE MARCHE COSTA RETTA

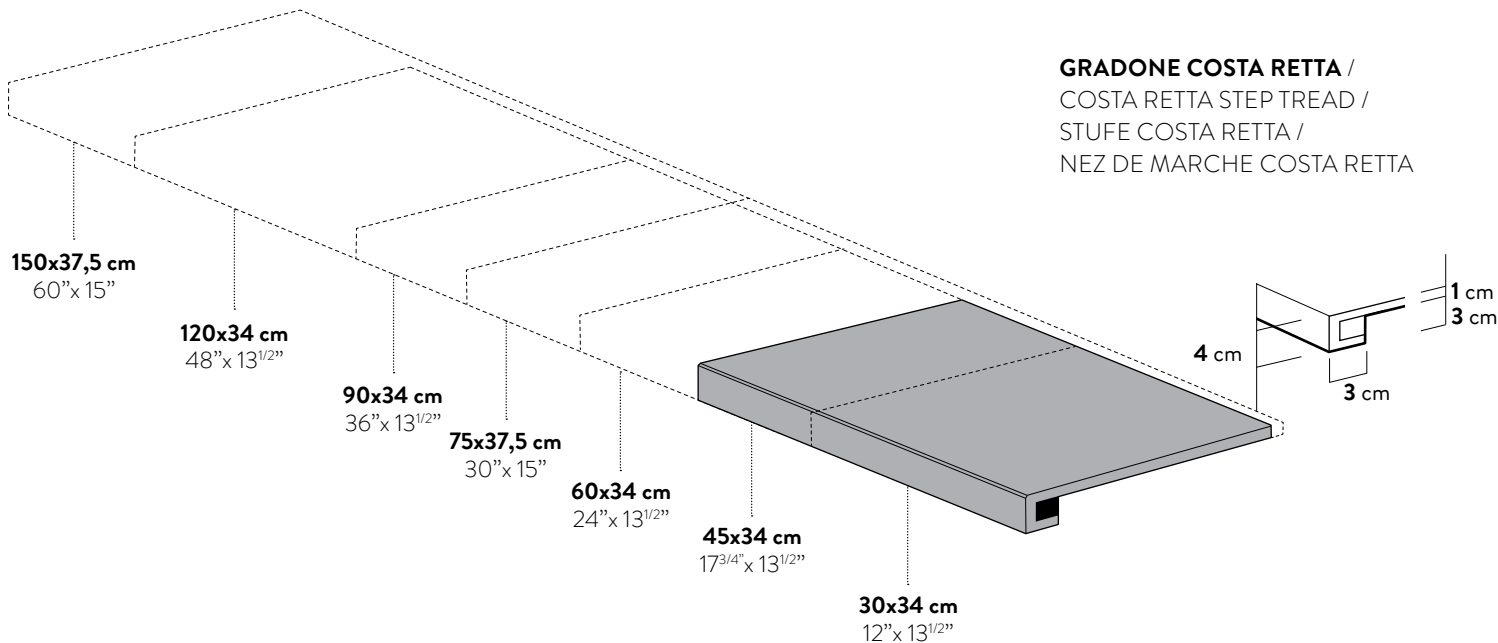

GRADINO CLASSICO /
STEP TREAD /
STUFENPLATTE /
NEZ DE MARCHE

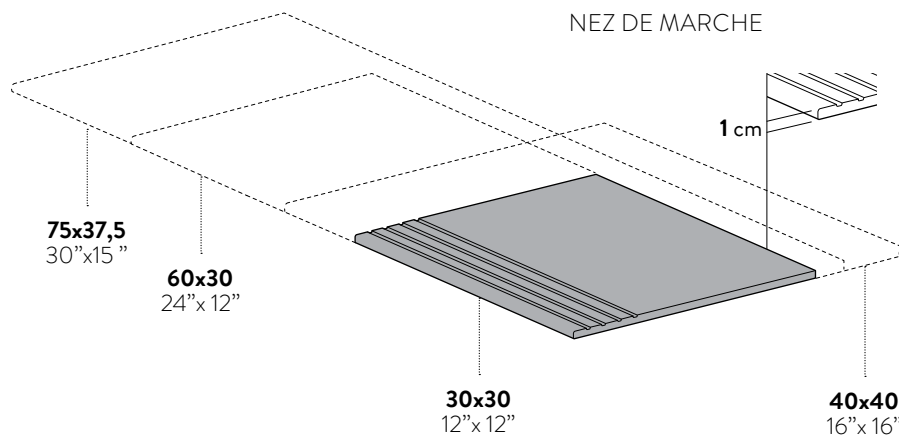

ELEMENTO A "L" COSTA RETTA /
COSTA RETTA "L" ÉLÉMENT /
LÄNGSSCHENKEL COSTA RETTA /
ÉLÉMENT EN "L" COSTA RETTA

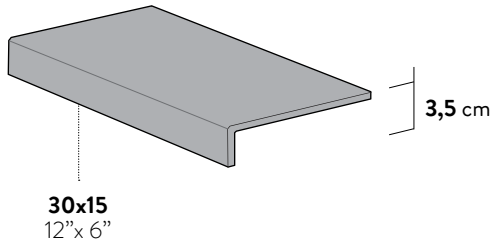

ELEMENTO A "L" /
"L" - SHAPED ÉLÉMENT /
SCHENKEL /
ÉLÉMENT EN "L"

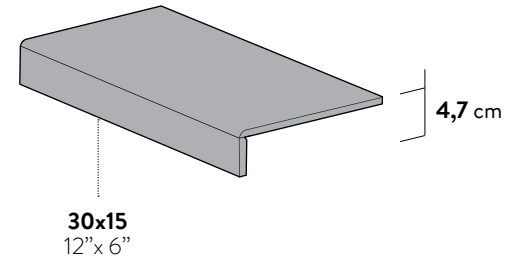

SGUSCIA /
COVE BASE /
HOHLKENLSOCKEL /
PLINTHE À GORGE

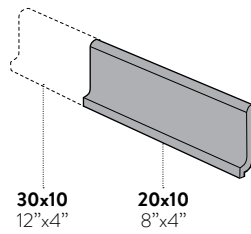

SGUSCIA UNIVERSALE /
UNIVERSAL COVE BASE /
HOHLKENLSOCKEL /
UNIVERSAL PLINTHE À TALON

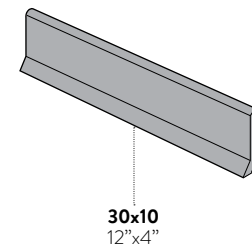

ANGOLO INTERNO /
INTERNAL ANGLE /
INNENECKE /
ANGLE INTÉRIEUR

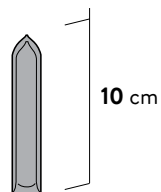

SPIGOLO ESTERNO /
EXTERNAL ANGLE /
AUSSENECKE /
ANGLE EXTÉRIEUR

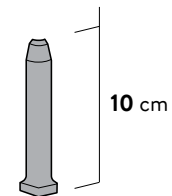

ANGOLO PISCINA

SWIMMING POOL CORNER EDGE /
BECKENRAND-ECKE /
ANGLE PISCINE

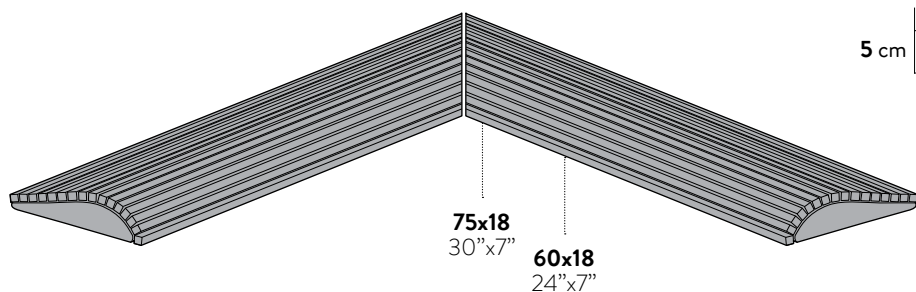

BORDO PISCINA

SWIMMING POOL EDGE /
BECKENRAND/
BORD PISCINE

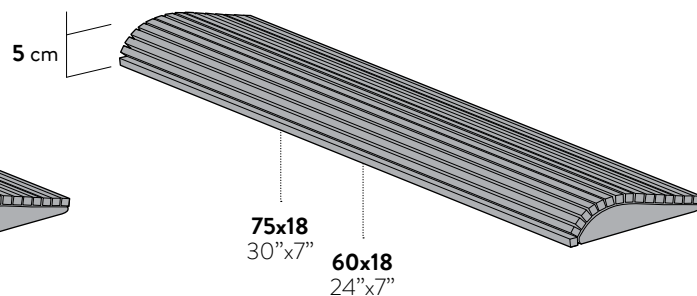

GRADONE TORO CM2

STEPTREAD GRADONE TORO CM2 /
STUFENPLATTE TORO CM2 /
NEZ DE MARCHE ÉPAISSEUR 2 CM

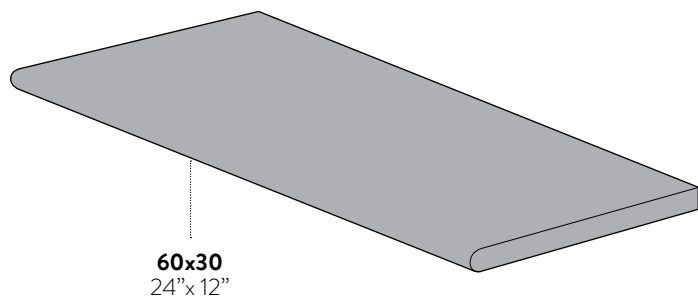

GRADONE BECCO CM2

STEPTREAD WITH HALF BULLNOSE EDGE /
STUFENPLATTE MIT ABGERUNDETER KANTE /
NEZ DE MARCHE AVEC BORD ARRONDI

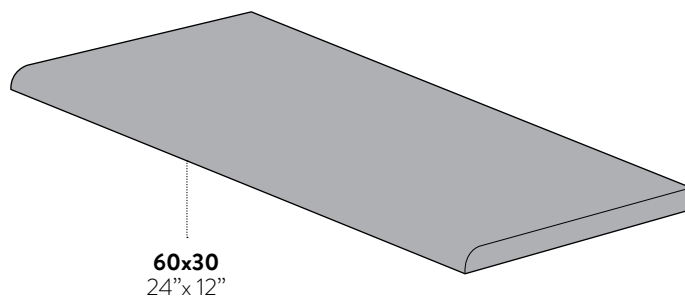

GRIGLIA CM2

WATER GRATE /
ABDECKPLATTE WASSERABLAUF /
GRILLE

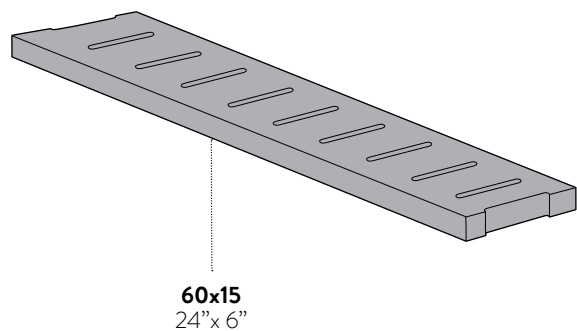

MOSAICO BLITZ

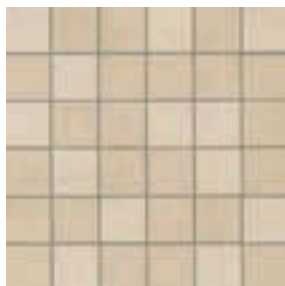

MOSAICO PIETRE



MOSAICO MARMI



MOSAICO CLASSIC



MOSAICO MICRO



MOSAICO MODULO BRICK



MODULO RANDOM 60x30 24"x12"



MODULO MAXI RANDOM 75x25 30"x9 3/4"



30x30
12"x12"

**MAXILAMA
90x22,5 36"x9"**



**DOMINO
30x30 12"x12"**



**MULTILAMA
30x15 12"x6"**



PALLADIANA

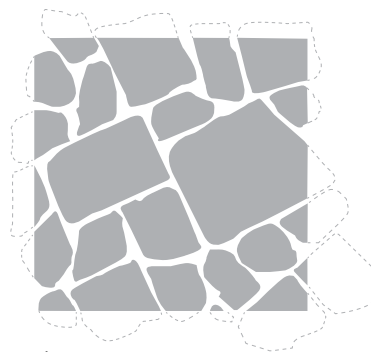

6 mq



- UNITÀ DI MISURA: mq
- QUANTITÀ MINIMA: 6 mq (EQUIVALENTI A 6 PIANI)
- UNIT OF MEASUREMENT: (sqm)
- MINIMUM QUANTITY ORDER : 6 sqms (CORRESPONDING TO SIX ROWS)
- EINHEIT: m²
- MINIMALE MENGE: 6 m² (ENTSPRECHEN 6 SCHICHTEN)
- UNITÉ DE MESURE: m²
- QUANTITÉ MINIMUM: 6 m² (ÉQUIVALENTS À 6 NIVEAUX)

- LA PALLADIANA VIENE FORNITA IN PACCHETTI DA 6 PIANI OGNUNO; OGNI PIANO DEVE QUINDI ESSERE POSATO CON FUGA ADEGUATA AD OTTENERE UN'AREA DI 1 mq MINIMO.

- THE PALLADIANA ITEM IS SUPPLIED IN BOXES WITH 6 ROWS EACH BOX; EACH ROW MUST BE INSTALLED WITH A JOINT RELATIVE TO A MINIMUM 1 sqm AREA COVERING.

- DIE PALLADIANA WIRD IN 6 KISTEN MIT JE 6 SCHICHTEN GELIEFERT; JEDE SCHICHT MUSS SOMIT MIT ANGEMESSENER FUGE VERLEGT WERDEN, UM EINE FLÄCHE VON MINIMUM 1 m² ZU GEWINNEN.

- LA PALLADIANA EST FOURNIE EN PAQUETS DE 6 NIVEAUX L'UN ; CHAQUE NIVEAU DOIT DONC ÊTRE POSÉ AVEC UN JOINT ADÉQUAT, AFIN D'OBTENIR UNE SURFACE DE 1 m² MINIMUM.

- LE FOTO PRESENTI SUL CATALOGO SONO INDICATIVE DEL SOLO EFFETTO D'INSIEME.

- THE PICTURES IN THIS CATALOGUE ARE APPROXIMATE AND THEY ARE JUST EXAMPLES OF THE GENERIC OVERVIEW.

- DIE ABBILDUNGEN AUF DEM KATALOG SIND NUR ALS BEISPIEL FÜR DEN EINDRUCK DES GESAMTBILDES.

- LES PHOTOS PRÉSENTES DANS LE CATALOGUE SONT INDICATIVES DU SEUL EFFET D'ENSEMBLE.

**IMBALLAGGI E PESI / PACKING AND WEIGHTS /
VERPACKUNG UND GEWICHT / EMBALLAGES ET POIDS**



FORMATI E SPESSORI/ SIZES AND THICKNESS/ FORMATE UND STÄRKE/ FORMATS ET ÉPAISSEUR	1500 x 750 mm 9,5 mm	1500 x 750 mm 10,0 mm	1500 x 750 mm 8,0 mm	1500 x 375 mm 8,0 mm	1500 x 250 mm 8,0 mm	1500 x 187 mm 8,0 mm	750 x 750 mm 10,0 mm	750 x 750 mm 10,0 mm	750 x 750 mm 8,0 mm	750 x 375 mm 9,5 mm	750 x 375 mm 10,0 mm
Collezione / Collection Kollektion / Collection	Innovative slabs Marmi high-tech	Innovative slabs Pietre naturali high-tech	Materie high-tech	Innovative slabs Legni high-tech	Innovative slabs Legni high-tech	Innovative slabs Legni high-tech	Innovative slabs Marmi high-tech	Innovative slabs Pietre naturali high-tech	Materie high-tech	Innovative slabs Marmi high-tech	Innovative slabs Pietre naturali high-tech
	ACTIVE						ACTIVE			ACTIVE	
Finitura / Finish Oberflächenausführung / Finition	LL/PR	AN/ST/SO	SO	AN	AN	AN	LL/PR	AN/ST/SO	SO	LL/PR	AN/ST
Pezzi scatola / Pieces box Stücke karton / Pièces boîte	2	2	2	2	2	3	2	2	2	3	3
Mq. Scatola / Sq. Mt. Box Qm. Karton / m ² boîte	2,25	2,25	2,25	2,25	1,125	1,125	1,125	1,125	1,125	0,844	0,844
Peso scatola / Weight box Gewicht karton / Poids boîte	51,75	51,75	51,75	41,67	20,835	20,835	20,835	25,875	25,875	20,835	19,40
Peso mq. / Sq. Mt. Weight Qm. Gewicht / Poids m ²	23,00	23,00	23,00	18,52	18,52	18,52	18,52	23,00	23,00	18,52	23,00
Scatole pallet / Box pallet Karton palette / Boîte palette	20	20	20	24	40	39	40	36	36	42	48
Mq. Pallet / Sq. Mt. Pallet Qm. Palette / m ² palette	45,00	45,00	45,00	54,00	45,00	43,88	45,00	40,50	40,50	47,25	40,512
Peso pallet / Weight pallet Gewicht palette / Poids palette	1035	1035	1035	1000	835	820	835	926	926	880	940



FORMATI E SPESSORI/ SIZES AND THICKNESS/ FORMATE UND STÄRKE/ FORMATS ET ÉPAISSEUR	1200 x 600 mm 10,0 mm	1200 x 600 mm 9,5 mm	1200 x 600 mm 20,0 mm	1200 x 300 mm 10,0 mm	1200 x 300 mm 10,0 mm	1200 x 300 mm 20,0 mm	1200 x 200 mm 10,0 mm	1200 x 200 mm 8,0 mm	1200 x 150 mm 10,0 mm	900 x 900 mm 10,0 mm	900 x 900 mm 9,5 mm	900 x 450 mm 10,0 mm	900 x 450 mm 9,5 mm
Collezione / Collection Kollektion / Collection	Pietre naturali high-tech	Marmi high-tech	Legni high-tech	Legni high-tech	Pietre naturali high-tech	Legni high-tech	Legni high-tech	Woodraw	Legni high-tech	Pietre naturali high-tech	Marmi high-tech	Pietre naturali high-tech	Marmi high-tech
	Greenstone Materie high-tech ACTIVE		Materie high-tech cm2 AROSHA KOLLEKTION	ACTIVE		cm2 AROSHA KOLLEKTION	ACTIVE		ACTIVE				
Finitura / Finish Oberflächenausführung / Finition	ST/SA/SL/BA SO/N	LL/PR	AN/ST	AN	N/BA	AN	AN	AN	AN	ST/SA	LL/PR	ST/SA	LL/PR
Pezzi scatola / Pieces box Stücke karton / Pièces boîte	2	2	2	1	3	3	2	4	6	6	2	2	3
Mq. Scatola / Sq. Mt. Box Qm. Karton / m ² boîte	1,44	1,44	1,44	0,72	1,08	1,08	0,72	0,96	1,44	1,08	1,62	1,62	1,215
Peso scatola / Weight box Gewicht karton / Poids boîte	31,824	30,00	30,00	32,12	24,17	23,88	32,12	21,485	24,78	24,17	35,80	34,00	26,80
Peso mq. / Sq. Mt. Weight Qm. Gewicht / Poids m ²	22,10	20,83	20,83	44,60	22,38	22,10	44,60	22,38	17,21	22,38	22,10	21,00	22,00
Scatole pallet / Box pallet Karton palette / Boîte palette	25	25	24	25	32	32	24	36	32	36	20	20	32
Mq. Pallet / Sq. Mt. Pallet Qm. Palette / m ² palette	36,00	36,00	34,56	18,00	34,56	34,56	17,28	34,56	46,08	38,88	32,40	32,40	38,88
Peso pallet / Weight pallet Gewicht palette / Poids palette	800	750	720	810	768,66	770	780	768,06	800	865	716	680	850

AN: Anticato / Antiqued / Antik / Antique
BA: Bamboo
BC: Bocciardato / Bushhammered / Gestockt / Bouchardé
HH: High-Honed
LL: Levigato e lucidato / Honed and polished / Geschliffen und poliert / Poli et lustré
N: Naturale / Natural / Naturbelassen / Naturel

PR: Prelevigato / Prepolished / Vorgeschliffen / Prépoli
SA: Satinato / Satin-finish / Satiniert / Satiné
SL: Semilucidato / Semi-polished / Semi-matt / Semi-lustré
SO: Soft
ST: Strutturato / Structured / Strukturiert / Structuré



FORMATI E SPESSORI/ SIZES AND THICKNESS/ FORMATE UND STÄRKE/ FORMATS ET ÉPAISSEUR	900x 225 mm 10,0 mm	900x 150 mm 10,0 mm	900x 110 mm 10,0 mm	600x 600 mm 20,0 mm	600 x 600 mm 10,0 mm	600 x 600 mm 10,0 mm	600 x 600 mm 9,5 mm	600 x 600 mm 9,0 mm	600 x 300 mm 10,0 mm	
Collezione / Collection Kollektion / Collection	Legni high-tech	Legni high-tech	Legni high-tech	CM2 Pietre naturali high-tech Materie high-tech 	Pietre naturali high-tech Greenstone Materie high-tech	Iridium	Marmi high-tech	Universe	Pietre naturali high-tech Greenstone Materie high-tech	
Finitura / Finish Oberflächenausführung / Finition	AN	AN	AN	ST	ST/SA/BC/HH/ SL/BA/SO/N	LL	SO	LL/PR	SA/HH/BC	ST/SA/BC/HH/ SL/BA/SO/N
Pezzi scatola / Pieces box Stücke karton / Pièces boîte	6	9	11	2	4	3	3	4	4	8
Mq. Scatola / Sq. Mt. Box Qm. Karton / m² boîte	1,215	1,215	1,089	0,72	1,44	1,08	1,08	1,44	1,44	1,44
Peso scatola / Weight box Gewicht karton / Poids boîte	27,24	27,24	24,415	32,00	30,50	22,50	24,00	29,00	29,00	30,50
Peso mq. / Sq. Mt. Weight Qm. Gewicht / Poids m²	22,42	22,42	22,42	44,44	21,15	20,85	22,22	20,15	20,15	21,15
Scatole pallet / Box pallet Karton palette / Boîte palette	36	36	40	30	30	40	40	30	30	32
Mq. Pallet / Sq. Mt. Pallet Qm. Palette / m² palette	43,74	43,74	43,56	21,60	43,20	43,20	43,20	43,20	43,20	46,08
Peso pallet / Weight pallet Gewicht palette / Poids palette	973,45	973,45	968,615	960	920	900	960	870	928	980

FORMATI E SPESSORI/ SIZES AND THICKNESS/ FORMATE UND STÄRKE/ FORMATS ET ÉPAISSEUR	600 x 300 mm 10,0 mm	600 x 300 mm 9,5 mm	600 x 300 mm 9,0 mm	600 x 150 mm 10,0 mm	600 x 150 mm 9,0 mm	600 x 100 mm 10,0 mm	600x 100 mm 10,0 mm	600 x 100 mm 9,0 mm	450 x 450 mm 9,5 mm	400 x 400 mm 9,0 mm	400 x 400 mm 9,0 mm
Collezione / Collection Kollektion / Collection	Iridium	Marmi high-tech	Universe	Pietre naturali high-tech Greenstone	Universe	Pietre naturali high-tech Greenstone	Legni high-tech	Universe	Marmi high-tech	Stardust	Porfido
Finitura / Finish Oberflächenausführung / Finition	LL/SO	LL/PR	SA/HH/BC	ST/SA/SL	SA	ST/SA/SL	AN	SA	LL/PR	LL	N
Pezzi scatola / Pieces box Stücke karton / Pièces boîte	8	8	8	10	10	10	15	10	6	7	7
Mq. Scatola / Sq. Mt. Box Qm. Karton / m² boîte	1,44	1,44	1,44	0,9	0,9	0,6	0,9	0,6	1,215	1,12	1,12
Peso scatola / Weight box Gewicht karton / Poids boîte	30,02	29,00	29,00	19,00	18,14	12,70	19,62	12,10	25,50	22,00	24,15
Peso mq. / Sq. Mt. Weight Qm. Gewicht / Poids m²	20,85	20,15	20,15	21,15	20,15	21,15	21,80	20,15	21,00	19,60	21,56
Scatole pallet / Box pallet Karton palette / Boîte palette	32	32	32	48	48	60	40	60	26	60	60
Mq. Pallet / Sq. Mt. Pallet Qm. Palette / m² palette	46,08	46,08	46,08	43,20	43,20	36,00	36,00	36,00	31,59	67,20	67,20
Peso pallet / Weight pallet Gewicht palette / Poids palette	960	928	928	912	861	750	779	714	663	1320	1450

**IMBALLAGGI E PESI / PACKING AND WEIGHTS /
VERPACKUNG UND GEWICHT / EMBALLAGES ET POIDS**

FORMATI E SPESSORI/ SIZES AND THICKNESS/ FORMATE UND STÄRKE/ FORMATS ET ÉPAISSEUR	300 x 300 mm 14,0 mm	300 x 300 mm 10,0 mm	300 x 300 mm 9,0 mm	300 x 300 mm 8,5 mm	300 x 300 mm 8,0 mm	300 x 300 mm 7,0 mm	300 x 150 mm 10,0 mm	200 x 200 mm 14,0 mm	200 x 200 mm 12,0 mm	200 x 200 mm 8,2 mm	150 x 150 mm 10,0 mm	
Collezione / Collection Kollektion / Collection	Porfido (Betel. Houston, Crystal, Nevada)	Pietre naturali high-tech	Stardust	Porfido	Porfido	Porfido (Kansas, Alaska, Nevada, Oregon)	Pietre naturali high-tech	Porfido (Betel. Houston, Crystal, Nevada)	Porfido (Betel. Houston, Crystal, Nevada)	Porfido	Pietre naturali high-tech	
Finitura / Finish Oberflächenführung / Finition	N	ST/SA	PR/LL	N	LL	N	ST/SA	N	N	N/ST	ST/SA	
Pezzi scatola / Pieces box Stücke karton / Pièces boîte	7	10	11	11	11	14	20	15	17	25	25	40
Mq. Scatola / Sq. Mt. Box Qm. Karton / m ² boîte	0,63	0,90	1,00	1,00	1,00	1,26	0,9	0,60	0,68	1,00	1,00	0,9
Peso scatola / Weight box Gewicht karton / Poids boîte	18,90	19,00	20,15	19,00	17,00	19,15	19,00	19,20	18,70	19,00	18,50	19,00
Peso mq. / Sq. Mt. Weight Qm. Gewicht / Poids m ²	30,00	21,15	20,15	19,00	17,00	15,20	21,15	32,00	27,50	19,00	18,50	21,15
Scatole pallet / Box pallet Karton palette / Boîte palette	60	60	60	60	60	60	60	80	80	80	80	60
Mq. Pallet / Sq. Mt. Pallet Qm. Palette / m ² palette	37,80	54,00	60,00	60,00	60,00	75,60	54,00	48,00	54,40	80,00	80,00	54,00
Peso pallet / Weight pallet Gewicht palette / Poids palette	1134	1142	1202	1135	1016	1143	1142	1530	1490	1510	1480	1142

**PEZZI SPECIALI
TRIMS /
FORMTEILE /
PIÈCES SPÉCIALES**

FORMATI E SPESSORI/ SIZES AND THICKNESS/ FORMATE UND STÄRKE/ FORMATS ET ÉPAISSEUR	600 x 300 mm 20,0 mm	600 x 300 mm 20,0 mm	1500 x 375 mm 8,0/10,0 mm	1500 x 375 mm 8,0 mm	1200 x 340 mm 10,0 mm	1200 x 340 mm 10,0 mm	900 x 340 mm 10,0 mm	900 x 340 mm 10,0 mm	750 x 375 mm 8,0/10,0 mm	750 x 375 mm 8,0 mm
Collezione / Collection Kollektion / Collection	CM2 Pietre naturali high-tech Materie high-tech 	CM2 Pietre naturali high-tech Materie high-tech 	Innovative slabs Pietre naturali high-tech Materie high-tech	Innovative slabs Legni high-tech	Pietre naturali high-tech Materie high-tech	Legni high-tech Greenstone	Pietre naturali high-tech	Legni high-tech	Innovative slabs Pietre naturali high-tech Materie high-tech	Innovative slabs Legni high-tech
Finitura / Finish Oberflächenführung / Finition	ST	ST	ST/AN/SO	AN	ST/SA/SO/N	AN/SA/SL	ST/SA	AN	ST/AN/SO	AN
Pezzi scatola / Pieces box Stücke karton / Pièces boîte	4	4	1	1	1	1	1	1	2	2
Mq. Scatola / Sq. Mt. Box Qm. Karton / m ² boîte	0,72 Lin. mt	0,72 Lin. mt	1,50 Lin. mt	1,50 Lin. mt	1,20 Lin. mt	1,20 Lin. mt	0,9 Lin. mt	0,9 Lin. mt	1,50 Lin. mt	1,50 Lin. mt
Peso scatola / Weight box Gewicht karton / Poids boîte	32,00	32,00	12,40	12,00	12,40	12,40	9,30	9,30	12,95	12,00

AN: Anticato / Antiqued / Antik / Antique
BA: Bamboo
BC: Bocciardato / Bushhammered / Gestockt / Bouchardé
HH: High-Honed
LL: Levigato e lucidato / Honed and polished / Geschliffen und poliert / Poli et lustré
N: Naturale / Natural / Naturbelassen / Naturel

PR: Prelevigato / Prepolished / Vorgeschliffen / Prépoli
SA: Satinato / Satin-finish / Satiniert / Satiné
SL: Semilucidato / Semi-polished / Semi-matt / Semi-lustré
SO: Soft
ST: Strutturato / Structured / Strukturiert / Structuré

Gradone costa retta / costa retta step tread /
 Stufe costa retta / nez de marche costa retta

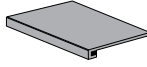

Gradino classico / Sep tread /
 Stufenplatte / Nez de marche

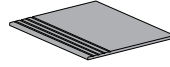

FORMATI E SPESSORI/ SIZES AND THICKNESS/ FORMATE UND STÄRKE/ FORMATS ET ÉPAISSEUR	600 x 340 mm 10,0 mm	450 x 340 mm 10,0 mm	300 x 340 mm 10,0 mm	300 x 340 mm 9,0 mm	750 x 375 mm 8,0/10,0 mm	600 x 300 mm 10,0 mm	400 x 400 mm 9,0 mm	300 x 300 mm 10,0 mm	300 x 300 mm 9,0 mm
Collezione / Collection Kollektion / Collection	Pietre naturali high-tech Greenstone Materie high-tech	Legni high-tech	Pietre naturali high-tech	Universe Greenstone	Innovative slabs Pietre naturali high-tech Materie high-tech	Pietre naturali high-tech Greenstone Materie high-tech	Stardust	Pietre naturali high-tech	Stardust
Finitura / Finish Oberflächenführung / Finition	ST/SA/SL/SO/N	AN	ST/SA	SA/ST/SL	ST/AN/SO	ST/SA/SL/HH/SO/N	LL	ST/SA	LL/PR
Pezzi scatola / Pieces box Stücke karton / Pièces boîte	4	4	4	4	3	8	7	11	11
Mq. Scatola / Sq. Mt. Box Qm. Karton / m ² boîte	2,40 Lin. mt	1,80 Lin. mt	1,20 Lin. mt	1,20 Lin. mt	2,25 Lin. mt	4,80 Lin. mt	2,70 Lin. mt	3,30 Lin. mt	3,30 Lin. mt
Peso scatola / Weight box Gewicht karton / Poids boîte	24,80	18,80	12,40	12,40	19,40	31,90	22,30	21,45	19,70

Gradino classico / Step tread /
 Stufenplatte / Nez de marche

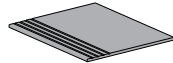

Gradone toro / step tread /
 Stufenplatte/nez de marche

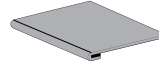

FORMATI E SPESSORI/ SIZES AND THICKNESS/ FORMATE UND STÄRKE/ FORMATS ET ÉPAISSEUR	300 x 300 mm 9,0 mm	300 x 300 mm 8,5 mm	300 x 300 mm 8,0 mm	300 x 300 mm 7,0 mm	1200 x 340 mm 9,5 mm	600 x 340 mm 9,5 mm	450 x 340 mm 9,5 mm	300 x 340 mm 9,5 mm
Collezione / Collection Kollektion / Collection	Universe	Porfido	Porfido	Porfido (Kansas, Alaska, Nevada, Oregon)	Marmi high-tech	Marmi high-tech	Marmi high-tech	Marmi high-tech
Finitura / Finish Oberflächenführung / Finition	SA	N	LL	N	PR/LL	PR/LL	PR/LL	PR/LL
Pezzi scatola / Pieces box Stücke karton / Pièces boîte	11	11	11	14	1	4	4	4
Mq. Scatola / Sq. Mt. Box Qm. Karton / m ² boîte	3,30 Lin. mt	3,30 Lin. mt	3,30 Lin. mt	3,30 Lin. mt	1,20 Lin. mt	2,40 Lin. mt	1,80 Lin. mt	1,20 Lin. mt
Peso scatola / Weight box Gewicht karton / Poids boîte	20,00	20,00	17,50	19,00	12,40	24,80	18,80	12,40

Angolare costa retta / Costa retta step
 Tread corner / Eckstufe costa retta /
 Nez de marche costa retta avec angle

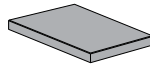

FORMATI E SPESSORI/ SIZES AND THICKNESS/ FORMATE UND STÄRKE/ FORMATS ET ÉPAISSEUR	1500 x 375 mm 8,0/10,0 mm	1500 x 375 mm 8,0 mm	1200 x 340 mm 10,0 mm	1200 x 340 mm 10,0 mm	900 x 340 mm 10,0 mm	900 x 340 mm 10,0 mm	750 x 375 mm 8,0/10,0 mm	750 x 375 mm 8,0 mm	600 x 340 mm 10,0 mm	600 x 340 mm 10,0 mm	450 x 340 mm 10,0 mm	300 x 340 mm 10,0 mm	300 x 340 mm 9,0 mm
Collezione / Collection Kollektion / Collection	Innovative Slabs Pietre naturali high-tech Materie high-tech	Innovative Slabs Legni high-tech	Pietre naturali high-tech Greenstone Materie high-tech	Legni high-tech	Pietre naturali high-tech	Legni high-tech	Innovative Slabs Pietre naturali high-tech	Innovative Slabs Legni high-tech	Pietre naturali high-tech	Greenstone	Legni high-tech	Pietre naturali high-tech	Universe Greenstone
Finitura / Finish Oberflächenführung / Finition	ST/SO/AN	AN	ST/SA/SL/SO/N	AN	ST/SA	AN	ST/SO/AN	AN	ST/SA/SO/N	SL/ST	AN	ST/SA	SA/ST/SL
Pezzi scatola / Pieces box Stücke karton / Pièces boîte	1	1	1	1	1	1	1	1	2	2	2	2	2
Mq. Scatola / Sq. Mt. Box Qm. Karton / m ² boîte	1,50 Lin. mt	1,50 Lin. mt	1,20 Lin. mt	1,20 Lin. mt	0,90 Lin. mt	0,90 Lin. mt	0,75 Lin. mt	0,75 Lin. mt	1,20 Lin. mt	1,20 Lin. mt	0,90 Lin. mt	0,60 Lin. mt	0,60 Lin. mt
Peso scatola / Weight box Gewicht karton / Poids boîte	12,40	12,00	13,70	13,70	10,30	9,30	12,95	12,20	13,60	13,60	10,40	6,90	6,90

**IMBALLAGGI E PESI / PACKING AND WEIGHTS /
VERPACKUNG UND GEWICHT / EMBALLAGES ET POIDS**











FORMATI E SPESSORI/ SIZES AND THICKNESS/ FORMATE UND STÄRKE/ FORMATS ET ÉPAISSEUR	Angolare toro /step tread corner/ Stufenplatte mit Ecke /Nez de marche avec angle				elemento a "L"/ "L" element / Schenkel / Élément en "L"	Elemento a "L" costa retta / costa retta "L" element / Längsschenkel costa retta / Élément en "L" costa retta	Bordo piscina / Swimming pool edge / Beckenrand/ Bord piscine		Angolo piscina / Swimming pool corner Edge / Beckenrand-Ecke / Angle Piscine		
	1200 x 340 mm 9,5 mm	600 x 340 mm 9,5 mm	450 x 340 mm 9,5 mm	300 x 340 mm 9,5 mm	300 x 150 mm 10,0 mm	300 x 150 mm 10,0 mm	750 x 180 mm -	600 x 180 mm -	750 x 180 mm -	600 x 180 mm -	
Collezione / Collection Kollektion / Collection	Marmi high-tech	Marmi high-tech	Marmi high-tech	Marmi high-tech	Pietre naturali high-tech	Pietre naturali high-tech	Pietre naturali high-tech	Pietre naturali high-tech	Pietre naturali high-tech	Pietre naturali high-tech	Pietre naturali high-tech
Finitura / Finish Oberflächenführung / Finition	PR/LL	PR/LL	PR/LL	PR/LL	ST	ST	ST	ST	ST	ST	ST
Pezzi scatola /Pièces box Stücke karton /Pièces boîte	1	2	2	2	8	8	1	1	1	1	1
Mq. Scatola /Sq. Mt. Box Qm. Karton / m ² boîte	1,2 Lin. mt	1,2 Lin. mt	0,9 Lin. mt	0,6 Lin. mt	2,40 Lin. mt	2,40 Lin. mt	0,135	0,108	0,54	0,42	
Peso scatola / Weight box Gewicht karton / Poids boîte	13,70	13,60	10,40	6,90	9,16	12,00	9,50	7,50	14,50	12,00	

FORMATI E SPESSORI/ SIZES AND THICKNESS/ FORMATE UND STÄRKE/ FORMATS ET ÉPAISSEUR	Griglia / Water grate / Abdeckplatte Wasserablauf / Grille	Listello / listel / Leisten / listel							Battiscopa / Bullnose / Stehsockel /Plinthe		
	600 x 150 mm 20,0 mm	900 x 90 mm 10,0 mm	900 x 90 mm 9,5 mm	750 x 90 mm 10,0 mm	600 x 100 mm 10,0 mm	600 x 90 mm 9,5 mm	600 x 90 mm 9,5 mm	450 x 90 mm 9,5 mm	900 x 90 mm 10,0 mm	900 x 90 mm 10,0 mm	900 x 90 mm 9,5 mm
Collezione / Collection Kollektion / Collection	CM2 Pietre naturali high-tech Materie high-tech 	Pietre naturali high-tech	Marmi high-tech	Innovative Slabs Marmi high-tech	Pietre naturali high-tech	Marmi high-tech	Iridium	Marmi high-tech	Pietre naturali high-tech	Legni high-tech	Marmi high-tech
Finitura / Finish Oberflächenführung / Finition	ST	ST/SA	LL	LL	HH	LL	LL/SO	LL	SA/ST	AN	LL/PR
Pezzi scatola /Pièces box Stücke karton /Pièces boîte	1	6	6	10	10	10	10	12	6	6	6
Mq. Scatola /Sq. Mt. Box Qm. Karton / m ² boîte	0,09 Lin. mt	5,40 Lin. mt	5,40 Lin. mt	7,5 Lin. mt	6,0 Lin. mt	6,0 Lin. mt	6,0 Lin. mt	5,4 Lin. mt	5,4 Lin. mt	5,4 Lin. mt	5,4 Lin. mt
Peso scatola / Weight box Gewicht karton / Poids boîte	3,80	12,55	12,55	12,00	13,40	13,50	11,50	12,70	12,54	12,54	12,50

Formati / sizes Formate / format								Battiscopa-listello / Bullnose-listel / Stehsockel-leisten / Plinthe-listel			
	750 x 90 mm 10,0 mm	750 x 90 mm 8,0/10,0 mm	750 x 65 mm 8,0 mm	600 x 90 mm 10,0 mm	600 x 90 mm 10,0 mm	600 x 90 mm 10,0 mm	600 x 90 mm 9,5-9 mm	450 x 90 mm 9,5 mm	400 x 90 mm 9,0 mm	300 x 90 mm 9,0 mm	300 x 90 mm 8,0 mm
Collezione / Collection Kollektion / Collection	Innovative Slabs Marmi high-tech	Innovative Slabs Pietre naturali high-tech Materie high-tech	Innovative Slabs Legni high-tech	Pietre naturali high-tech Materie high-tech	Legni high-tech	Iridium	Marmi high-tech Universe	Marmi high-tech	Stardust	Stardust	Porfido
Finitura / Finish Oberflächenführung / Finition	LL/PR	ST/SO/AN	AN	HH/SA/ST/ SO/N	AN	LL/SO	LL/PR/SA	LL/PR	LL	LL	LL
Pezzi scatola /Pièces box Stücke karton /Pièces boîte	10	10	10	10	10	10	10	12	12	12	12
Mq. Scatola /Sq. Mt. Box Qm. Karton / m ² boîte	7,50 Lin. mt	7,50 Lin. mt	7,50 Lin. mt	6,0 Lin. mt	6,0 Lin. mt	6,0 Lin. mt	6,0 Lin. mt	5,4 Lin. mt	4,8 Lin. mt	3,60 Lin. mt	3,60 Lin. mt
Peso scatola / Weight box Gewicht karton / Poids boîte	12,00	12,00	9,10	10,90	12,00	11,43	11,43	12,70	8,70	6,00	6,00

AN: Anticato / Antiqued / Antik / Antique
BA: Bamboo
BC: Bocciardato / Bushhammered / Gestockt / Bouchardé
HH: High-Honed
LL: Levigato e lucidato / Honed and polished / Geschliffen und poliert / Poli et lustré
N: Naturale / Natural / Naturbelassen / Naturel

PR: Prelevigato / Prepolished / Vorgeschliffen / Prépoli
SA: Satinato / Satin-finish / Satiniert / Satiné
SL: Semilucidato / Semi-polished / Semi-matt / Semi-lustré
SO: Soft
ST: Strutturato / Structured / Strukturiert / Structuré

FORMATI E SPESSORI/ SIZES AND THICKNESS/ FORMATE UND STÄRKE/ FORMATS ET ÉPAISSEUR	Battiscopa-listello / Bullnose-listell / Stehsokkel-leisten / Plinthe-listel			Tozzetto			Sguscia universale / Universal cove base / Hohlkensäkel / Universal plinthe à talon	Sguscia / cove base / Hohlkensäkel / plinthe à gorge		Angolo / angle / necke / angle
	 300 x 80 mm 10,0 mm	 300 x 80 mm 9,0 mm	 300 x 80 mm 8,0 mm	 90 x 90 mm 9,5 mm	 90 x 90 mm 9,0 mm	 90 x 90 mm 8,5 mm	 300 x 100 mm 9,0/8,5 mm	 300 x 100 mm 9,0/8,5 mm	 200 x 100 mm 8,5 mm	 h. 10 cm 4 °
Collezione / Collection Kollektion / Collection	Pietre naturali high-tech	Stardust	Porfido	Marmi high-tech	Stardust	Porfido	Porfido	Porfido	Porfido	Porfido
Finitura / Finish Oberflächenausführung / Finition	ST/SA	PR	N	LL	LL	LL	N	N	N	N
Pezzi scatola / Pieces box Stücke karton / Pièces boîte	36	36	36	12	12	12	30	30	35	1
Mq. Scatola / Sq. Mt. Box Qm. Karton / m ² boîte	10,8 Lin. mt	10,8 Lin. mt	10,8 Lin. mt	1,08 Lin. mt	1,08 Lin. mt	1,08 Lin. mt	9,00 Lin. mt	9,00 Lin. mt	7,00 Lin. mt	-
Peso scatola / Weight box Gewicht karton / Poids boîte	17,28	17,00	17,00	2,04	2,00	2,00	16,00	16,00	16,00	-

CONDIZIONI GENERALI DI VENDITA

1) NORMATIVA CONTRATTUALE - Le presenti condizioni generali, salvo eventuali modificazioni o deroghe concordate per iscritto, disciplinano tutti i contratti di vendita fra noi e l'acquirente, quindi tanto il contratto concluso con l'accettazione del presente ordine che qualsiasi contratto futuro relativo alle forniture dei prodotti della nostra società ordinati con successive e distinte commissioni. Le variazioni delle condizioni generali di vendita, le transazioni e gli abbuoni, anche se effettuati su iniziativa dei nostri Agenti, saranno impegnative per noi solo dopo nostra eventuale conferma scritta e comunque limitate ai contratti cui si riferiscono.

2) OGGETTO DELLA FORNITURA - La fornitura comprende solamente le prestazioni, i materiali ed i quantitativi specificati nella nostra conferma d'ordine o in altre comunicazioni scritte provenienti da noi. Il testo della nostra conferma d'ordine prevarrà in ogni caso sul testo difforme della eventuale offerta o della ordinazione.

L'esecuzione parziale dell'ordine senza preventiva conferma non significa nostra approvazione per l'intero ordine, bensì approvazione parziale relativamente alla merce consegnata. In questo caso la ricezione della merce equivarrà ad accettazione da parte dell'acquirente della nuova proposta contrattuale.

3) CONFERMA D'ORDINE - Qualora nella nostra conferma d'ordine esistano differenze nei singoli elementi che la compongono rispetto alle intese od alle ordinazioni, il compratore che non abbia contestato con lettera raccomandata spedita entro dieci giorni dalla ricezione della conferma tali differenze, è tenuto ad accettarla così come è stata redatta.

4) CONSEGNE - La merce, anche se venduta "franco arrivo", o franco domicilio del compratore, viaggia a rischio e pericolo di quest'ultimo ed ogni nostra responsabilità cessa con la consegna al vettore, nei confronti del quale il compratore, effettuate le opportune verifiche, dovrà sporgere eventuali reclami. Le spedizioni, via mare o via terra, concernenti forniture sull'estero, vengono

effettuate in base alle condizioni scelte di volta in volta, riportate negli "INCOTERMS" approvati dalla Camera di Commercio Internazionale nel 1953 e nei successivi.

5) TERMINI DI CONSEGNA - Il termine stabilito per la consegna della merce deve intendersi a favore di entrambi i contraenti. Qualora il materiale sia disponibile a magazzino, la ceramica Ariostea si impegna a spedirlo entro 8 giorni dalla data di ricevimento ordine, pertanto non verranno emesse conferme d'ordine. Salvo l'inserimento di particolari clausole, esso deve di norma considerarsi puramente indicativo e non essenziale. Quando siano intervenute modificazioni al contratto, il termine resta prorogato per un periodo uguale a quello inizialmente stabilito.

Ogni evento di forza maggiore sospende la decorrenza del termine per tutta la sua durata. Se in conseguenza di eventi di forza maggiore il contratto non potrà trovare esecuzione entro i 60 giorni successivi al termine convenuto, ognuna delle due parti avrà la facoltà di recedere dal contratto stesso.

In tal caso la dichiarazione di recesso dovrà essere spedita alla controparte, a mezzo lettera raccomandata con ricevuta di ritorno entro i dieci giorni successivi allo scadere dei predetti 60 giorni, restano esclusi reciproci diritti a indennizzi od a risarcimenti.

6) PAGAMENTI - Il luogo di pagamento è fissato presso la nostra Sede Amministrativa in Castellarano (Reggio E.) anche nel caso di emissione di tratte o ricevute bancarie, ovvero di rilascio di effetti cambiari, eventuale deroga a quanto sopra sarà valida soltanto se da noi concessa in forma scritta.

Per i pagamenti previsti in più rate l'importo dell'iva sarà comunque riscosso a mezza ricevuta bancaria con scadenza a 30 giorni data fattura. Il ritardo del pagamento, anche parziale delle nostre fatture oltre la pattuita scadenza darà luogo alla immediata decorrenza degli interessi di mora, calcolati al tasso ufficiale di sconto aumentato di 6 punti. Inoltre il mancato o ritardato pagamento delle fatture per qualsivoglia ragione ci darà diritto, impregiudicata ogni altra iniziativa, di pretendere il pagamento anticipato delle restanti forniture, oppure di ritenere

GENERAL SALES CONDITIONS

1) CONTRACTUAL REGULATIONS - These general sales conditions, save any modifications or variations agreed upon in writing, govern all sales contracts between us and the purchaser, thus including the contract concluded with the acceptance of this present order as well as any future contract related to the supply of our company's products ordered with subsequent and distinct commissions. Any variations on the general sales conditions, the transactions and allowances, even if made on the initiative of our Agent, will be binding for us only upon our written confirmation and in any case limited to the contracts to which they refer.

2) SUBJECT OF THE SUPPLY - The supply includes only the services, materials, and quantities specified in our acknowledgment of order or in other written communication sent by us. Should there be any differences in the offer or order, our acknowledgment of order is to be considered the only valid document. Partial processing of the order without our previous acknowledgment does not mean that we have approved the complete order, but rather partial acknowledgment relative to the goods delivered. In this case, reception of the goods shall be equivalent to acceptance on the part of the purchaser of the new contractual provisions.

3) ACKNOWLEDGMENT OF ORDER - Should there be any difference in the single items in our acknowledgment or order with respect to the agreements or orders, the buyer who has not made a claim by registered letter sent within ten days of receiving the acknowledgment shall be obliged to accept the acknowledgment as it is.

4) DELIVERY - The goods, even if sent freightpaid or free delivered to the buyer's premises, travel at the risk and responsibility of the buyer; all our responsibility ceases upon delivery of goods to the carrier. After the buyer has inspected the goods, any claims should be made to the carrier. Shipments by sea or by land regarding supplies abroad are made on the basis of the conditions chosen for each

specific case as specified in the "INCOTERMS" approved by the international Chamber of Commerce in 1953 and subsequent.

5) TERMS OF DELIVERY - The delivery date established must be mutually acceptable to both parties. If the material is available in our warehouse, Ceramica Ariostea undertake to ship it within 8 days of receiving the order, therefore no order confirmation will be issued. Unless specific clauses are introduced, this date is to be considered purely indicative and not binding. In the event that the contract is modified, the delivery date is extended for a period equal to that initially agreed upon.

Should any event caused by force majeure occur, the terms of delivery are suspended for the entire duration of said event. If, as a result of events of force majeure, the contract cannot be executed within 60 days of the date agreed upon, both parties shall be entitled to withdraw from the contract. In such case, the declaration of withdrawal must be sent to the counterpart by registered letter with return receipt within 10 days of the expiry of the aforementioned 60 days, and any indemnity or compensations are excluded.

6) PAYMENT - Payment is to be remitted to our registered office in Castellarano (Reggio E.) even if bills of exchange or bank drafts are issued; any variation to the aforementioned shall be valid only if approved by us in writing.

Delayed payment, even if only partial, of our invoices beyond the stipulated due date, shall entitle us to the immediate charge of interest on arrears in the order of the official rate increased by six points. Non-payment or delayed payment of our invoices - for any reason whatsoever - gives us the indisputable right to demand advance payment for the remaining supply, without prejudice of any other action, or to consider the contract suspended or annulled, and to annul the practice of any other contracts that may be in force, without giving the buyer the right to any type of refund or compensation for damages, or other.

temporaneamente sospeso o definitivamente risolto il contratto e di annullare l'evasione di eventuali altri ordini in corso, senza che il compratore possa avanzare pretese di compensi, indennizzi od altro.

7) SOLVE ET REPETE - Nessuna eccezione, salvo quelle di nullità, annullabilità e rescissione del contratto, può essere opposta dall'acquirente, al fine di ritardare od evitare il pagamento.

8) RISERVA DI PROPRIETÀ - Nel caso in cui il pagamento, per accordi contrattuali, debba essere effettuato in tutto o in parte dopo la consegna, i prodotti consegnati restano di nostra proprietà fino all'integrale pagamento del prezzo.

9) GARANZIA - I nostri materiali sono garantiti conformi alle Norme UNI-DIN-EN attualmente in vigore. La nostra garanzia è limitata ai materiali di 1ª scelta con tolleranza del 5% (cinqueper cento) circa. Qualsiasi garanzia per vizi rimane quindi espressamente esclusa per i materiali di 2ª e di 3ª scelta o di stock che, come le partite occasionali, si intendono sempre vendute come "viste e piaciute". Eventuali reclami e contestazioni dovranno essere notificati, a pena di decadenza, a mezzo lettera raccomandata, unicamente presso la nostra Sede Amministrativa in Castellarano (Reggio E.), prima della posa in opera del materiale e comunque nei termini di legge. La posa in opera del materiale determina la decadenza dalla azione per vizi tanto palesi che occulti, importando rinuncia implicita alla garanzia di cui all'art. 1490 c.c. Le differenze di tonalità non possono essere denunciate come vizio del materiale. In ogni caso la nostra garanzia comprende unicamente la sostituzione del materiale riscontrato difettoso con esclusione di ogni ulteriore e diversa obbligazione. Eventuali contestazioni sul materiale non daranno diritto all'Acquirente di sospendere o ritardare in tutto o in parte il pagamento nei termini pattuiti, ai sensi del precedente articolo 7.

Ogni questione relativa all'accertamento del diritto alla garanzia, alla determinazione del danno ed alla sua quantificazione che non possa essere bonariamente risolta tra le parti sarà rimessa all'arbitrato libero di un arbitro unico da costituirsi e

svolgersi secondo il regolamento della Camera Arbitrale istituita presso il Centro Ceramico di Bologna che le parti dichiarano di accettare incondizionatamente ed inappellabilmente.

10) DIVIETO D'ESPORTAZIONE - Salvo accordi in contrario, è fatto divieto all'Acquirente di esportare i nostri materiali a lui forniti, o di cederli a Ditte o persone che ne facciano oggetto di esportazione.

11) CLAUSOLA ARBITRALE - Ad eccezione delle controversie inerenti il pagamento del prezzo ed alle relative azioni esercitate in via monitoria e nel giudizio ordinario, che rimangono di competenza dell'autorità giurisdizionale italiana, qualunque altra controversia che dovesse insorgere relativamente alla conclusione e/o esecuzione e/o risoluzione e/o interpretazione del presente contratto sarà devoluta ad un Collegio di tre arbitri nominati uno da ciascuna delle parti e uno di comune accordo o in caso di disaccordo dal Presidente della C.C.I.A.A. di Reggio E. a richiesta della parte più diligente.

La parte che intende avviare l'arbitrato deve comunicarlo all'altra con lettera raccomandata contenente la nomina del proprio arbitro e la sua accettazione. L'altra parte dovrà nominare il proprio arbitro nel termine di quindici giorni dalla data di ricezione della raccomandata, comunicando tale nomina e la relativa accettazione entro il termine indicato. In difetto l'altra parte potrà richiedere la nomina del secondo arbitro al Presidente della C.C.I.A.A. di Reggio E. Gli arbitri decideranno secondo diritto e nel rispetto del principio del contraddittorio. Il lodo dovrà essere deliberato nel termine di 90 giorni decorrenti dalla data di accettazione dell'ultimo arbitro. L'arbitrato avrà sede a Reggio E.

12) EFFETTIVITÀ DI CIASCUNA CONDIZIONE - Le condizioni generali di vendita sopra riportate non devono assolutamente intendersi come clausole di puro stile. Esse sono effettive e rappresentano fedelmente la volontà negoziale delle parti.

7) SOLVE ET REPETE - No exception, save that of nullity, possibility of annulment, or rescission of the contract, can be posed by the purchaser with the purpose of delaying or avoiding payment.

8) RETENTION OF TITLE - In the event that payment, by contractual agreement, is to be remitted - in whole or in part - after delivery of the goods, the products delivered remain our property until complete payment of the total amount due is made.

9) GUARANTEE - Our products are guaranteed to be in compliance with the UNI-DIN-EN standards in force. Our guarantee is limited to first choice material, with a tolerance of approximately 5% (five percent). Any guarantee against defects is thus expressly excluded for second or third choice or stock material, as the special sales lots are always sold as "seen and approved".

Any claims must be made, on pain of forfeiture, by registered letter sent to our registered office in Castellarano (Reggio E.) before the materials are laid and in any case according to the terms of the law. Once the material is laid, any claim for defects either obvious or hidden is no longer valid, and the guarantee is to be considered explicitly invalidated according to art. 1490 of Italian Civil Code. Any difference in colour shades cannot be considered as material defects.

In any case, our guarantee only includes the replacement of material found to be defective with the exclusion of any farther or different obligation.

Claims made on material do not give the purchaser the right to suspend or delay, in whole or in part, the payment within the stipulated terms, according to article 7. Any dispute arising in respect to the seller's, Arostea's product and its guarantee there of including, but not limited to, damages which are not settled peaceably between parties shall be submitted to independent arbitration. The arbitration proceeding shall be held before one arbitrator. The arbitrator shall be appointed and the arbitration proceeding shall be conducted in accordance with rules and regulations of Arbitration Board, the ("Camera Arbitrale"), located at the Centro

Ceramico of Bologna, Italy. All proceedings shall be conducted at the Centro Ceramico. All parties unconditionally accept the provisions of this paragraph and agree not to contest its validity.

10) PROHIBITION TO EXPORT - Excepting other agreements, the purchaser is prohibited to export our materials supplied to him, or to transfer them to companies or persons with the object of exportation.

11) ARBITRATION CLAUSE - Except for disputes from payment and from the relative monetary actions or in ordinary legal proceedings which remain the competence of the Italian legal authorities, any other dispute arising from the conclusion and/or execution and/or resolution and/or interpretation of this contract will be referred to a Board of Arbitrators, with one arbitrator nominated by each party and the third by common consent, or in the event of disagreement, by the President of the C.C.I.A.A. (Chamber of Commerce) of Reggio E. (Italy) upon request of the most diligent party. The party that intends to begin arbitration proceedings must notify the other party by registered letter containing the name of its chosen arbitrator and his acceptance. The other party must nominate its own arbitrator within fifteen days of date on which the registered letter is received, and the relative acceptance within the term indicated. In default, the first party shall be entitled to request the nomination of the second arbitrator by the President of the C.C.I.A.A. (Chamber of Commerce) of Reggio E. (Italy). The arbitrators shall decide according to the law and respecting the principle of cross-examination. The award must be decided upon within 90 (ninety) days from the date of acceptance of the last arbitrator. The arbitration site shall be Reggio E. (Italy).

12) VALIDITY OF EACH CONDITION - The aforementioned general sales conditions are not to be considered in any way clauses of form. These conditions are effective to all intents and purposes and faithfully represent the contractual will of the parties.

ALLGEMEINE VERKAUFSBEDINGUNGEN

1) VERTRAGSBESTIMMUNGEN - Die vorliegenden Allgemeinen Verkaufsbedingungen - ausgeschlossen eventuelle schriftlich vereinbarte Abänderungen oder Abweichungen - regeln alle Kaufverträge zwischen uns und dem Käufer, d.h. folglich sowohl den durch die Annahme des vorliegenden Auftrags abgeschlossenen Vertrag als jeden weiteren zukünftig bezüglich der Lieferung von unserer Gesellschaft hergestellter Produkte abgeschlossenen Vertrag. Abänderungen der allgemeinen Verkaufsbedingungen, Transaktionen und Gutschriften - auch wenn von unseren Vertretern ausgeführt - sind für uns nur verbindlich, wenn wir diese eventuell schriftlich bestätigen und beschränken sich auf jeden Fall nur auf die Verträge, auf die sie sich beziehen.

2) GEGENSTAND DER LIEFERUNG - Die Lieferung umfaßt ausschliesslich die Leistungen, Artikel und Mengen, die in unserer Auftragsbestätigung oder in anderen schriftlichen Mitteilungen von uns angegeben sind. Bei eventuellen Abweichungen des Wortlauts des Angebots oder der Bestellungen vom Wortlaut unserer Auftragsbestätigung ist die letztere gültig.

Die teilweise Ausführung des Auftrags ohne vorhergehende Bestätigung kann nicht als unsere Billigung des gesamten Auftrags angesehen werden, sondern stellt nur eine Billigung bezüglich der gelieferten Ware dar. In diesem Fall wird die Annahme der Ware als Billigung des neuen Vertragsvorschlages seitens des Käufers angesehen.

3) AUFTRAGSBESTÄTIGUNG - Wenn unsere Auftragsbestätigung Abweichungen bei den sie bildenden Elementen hinsichtlich der Vereinbarungen oder Bestellungen aufweist, hat der Käufer sie anzunehmen, wenn er diese Abweichungen nicht innerhalb von zehn Tagen nach Erhalt der Auftragsbestätigung per Einschreiben beanstandet.

4) WARENÜBERGABE - Auch wenn die Ware frei Ort oder frei Käufersitz geliefert wird, reist die Ware auf Gefahr und Risiko des Käufers und unsere Haftung erlischt bei der Übergabe der Ware an den Spediteur, bei dem der Käufer - nach Ausführung der erforderlichen Kontrollen - seine eventuellen Reklamationen einzureichen hat.

Der Versand auf dem See- oder Landweg von Lieferungen in das Ausland erfolgt unter

den von Fall zu Fall gewählten und in den von der Internationalen Handelskammer 1953 und darauff. gebilligten "INCOTERMS" enthaltenen Bedingungen.

5) LIEFERFRISTEN - Die für die Ware festgelegte Lieferfrist ist zu Gunsten beider Vertragsparteien anzusehen. Soweit das Material am Lager vorrätig ist, verpflichtet sich Ariosteas, es innerhalb von 8 Tagen von Eingang der Bestellung zu verschicken und es werden keine Auftragsbestätigungen ausgestellt. Falls keine besonderen Klauseln vereinbart wurden, ist die Lieferfrist normalerweise als nicht grundlegende Angabe anzusehen. Nach Abänderungen des Vertrags wird die Lieferfrist um die ursprüngliche Lieferfrist verlängert.

Jedes Ereignis höherer Gewalt unterbricht den Ablauf der Lieferfrist über die gesamte Dauer des Ereignisses höherer Gewalt. Wenn der Vertrag aufgrund höherer Gewalt nicht innerhalb von 60 Tagen nach dem vereinbarten Liefertermin ausgeführt werden kann, sind beide Parteien berechtigt vom Vertrag zurückzutreten. In diesem Fall muß die Rücktrittserklärung der anderen Partei mittels Einschreiben mit Rückschein spätestens zehn Tage vor Ablauf der o.g. 60 Tage zugesendet werden. Ein Anrecht auf Entschädigung und Schadensersatz besteht nicht.

6) ZAHLUNGEN - Die Zahlung erfolgt an unseren Verwaltungssitz in Castellarano (Reggio E.), und zwar auch im Fall von Tratten oder Bankquittungen sowie bei der Ausstellung von Wechseln. Andere Vereinbarungen sind nur gültig, wenn sie von uns schriftlich bestätigt sind. Bei einer eventuell vereinbarten Ratenzahlung wird die Mehrwertsteuer auf jeden Fall per Bankquittung innerhalb von 30 Tagen ab Rechnungsdatum fällig. Bei einer verspäteten Bezahlung unserer Rechnungen werden sofort Verzugszinsen fällig, die unter Zugrundelegung des um 6 Punkte erhöhten offiziellen Diskontsatzes berechnet werden. Bei nicht oder verspätet bezahlten Rechnungen sind wir auf jeden Fall berechtigt, sofort die Bezahlung der restlichen Lieferungen zu verlangen oder den Vertrag als zeitweilig unterbrochen oder als aufgelöst zu betrachten und die Auslieferung eventueller weiterer Aufträge zu stornieren, ohne daß der Käufer ein Anrecht auf Schadensersatz, Entschädigung, usw. besitzt. Ferner behalten wir uns in diesem Fall das Recht zu weiteren Schritten vor.

CONDITIONS GENERALES DE VENTE

1) RÉGLEMENTATION CONTRACTUELLE - Tous les contrats de vente établis entre l'acquéreur et nous sont soumis aux présentes conditions générales, exception faite d'éventuelles modifications ou dérogations concordées par écrit, et ainsi, aussi bien, le contrat conclu avec acceptation de la commande présente, que tout autre contrat futur relatif aux fournitures des produits de notre société faisant l'objet de commandes distinctes et successives. Les variations des conditions générales de vente, les transactions et les remises, même effectuées sur l'initiative de nos Agents, ne représenteront un engagement pour nous qu'après notre éventuelle confirmation écrite et seront de toute façon limitées aux contrats auxquels elles se rapportent.

2) OBJET DE LA FOURNITURE - La fourniture ne comprend que les prestations, les matériaux et les quantités spécifiées dans notre confirmation de commande ou dans d'autres communications écrites par nous. Le texte de notre confirmation de commande prévaudra de toute façon sur le texte non conforme de l'offre ou de la commande éventuelle.

L'exécution partielle de la commande, sans confirmation préalable, n'est pas synonyme de notre approbation pour la commande dans son entier mais ne représente que l'approbation partielle relative à la marchandise livrée. Dans ce cas, la réception de la marchandise équivaudra à l'acceptation de la part de l'acquéreur de la nouvelle proposition contractuelle.

3) CONFIRMATION D'ORDRE - S'il devait exister, dans notre confirmation d'ordre, des différences dans les éléments qui la composent, par rapport aux ententes ou aux commandes, l'acheteur qui n'aura pas contesté ces différences par lettre recommandée envoyée dans les dix jours suivant la réception de la confirmation, devra l'accepter telle qu'elle a été rédigée.

4) LIVRAISON - La marchandise, même vendue "franco arrivée" ou franco domicile de l'acheteur voyage au risque et péril de ce dernier, et toute responsabilité de notre part prend fin avec la livraison au transporteur, auquel l'acheteur, après avoir effectué les contrôles opportuns, devra présenter les réclamations éventuelles.

Les expéditions par mer ou par terre, concernant les fournitures pour l'étranger, sont effectuées sur la base des conditions choisies d'une fois sur l'autre, qui figurent dans les "INCOTERMES" approuvés par la Chambre de Commerce Internationale en 1953 et dans les successifs.

5) DÉLAIS DE LIVRAISON - Le délai établi pour la livraison de la marchandise doit s'entendre à faveur des deux contractants. Si le matériel devait être disponible en stock, Ceramica Ariosteas s'engage à l'expédier dans les 8 jours suivant la date de réception de la commande; c'est la raison pour laquelle, aucune confirmation de commande ne sera émise. Exception faite d'insertions de clauses particulières, le délai doit généralement être considéré comme purement indicatif et non essentiel. Quand des modifications sont apportées au contrat, le délai est renouvelé pour une période égale à celle qui avait été initialement établie.

Tout événement de force majeure suspend le départ de la période de validité du délai pour toute sa durée. Si à la suite d'événements de force majeure le contrat ne peut être exécuté dans les 60 jours suivant le délai convenu, chacune des deux parties aura la faculté de résilier le contrat en question. Dans ce cas, la déclaration de résiliation devra être envoyée à la partie adverse par lettre recommandée avec accusé de réception dans les dix jours qui suivent la date d'expiration des 60 jours mentionnés précédemment, les droits réciproques à indemnisations ou à dédommagements restant exclus.

6) PAIEMENTS - Le lieu de paiement est fixé auprès de notre Siège Administratif à Castellarano (Reggio Emilia), même dans le cas d'émission de traites ou de reconnaissance bancaire, c'est à dire de reçu de billets de change, une éventuelle dérogation à ce qui vient d'être énoncé ne sera valable que si c'est nous la concédons par écrit.

Pour les paiements prévus en plusieurs versements, le montant de la T.V.A. sera de toute façon encaissé par reconnaissance bancaire avec une échéance à 30 jours de la date de la facture. Si le retard du paiement, même partiel de nos factures dépasse la date d'expiration convenue, les intérêts de retard commenceront immédiatement à courir et seront calculés sur la base du taux officiel d'escompte augmenté de 6 points. En outre, l'absence ou le retard de paiement des factures - quelle que soit la raison - nous donnera

7) SOLVE ET REPETE - Keine Ausnahme, abgesehen von Ungültigkeit, Auflösbarkeit und Kündigung des Vertrags, kann der Kunde geltend machen, um die Zahlung zu verspäten oder zu vermeiden.

8) EIGENTUMSVORBEHALT - Falls die Bezahlung aufgrund der vertraglichen Bestimmungen ganz oder teilweise nach der Lieferung erfolgt, verbleibt die gelieferte Ware bis zur vollständigen Bezahlung unser Eigentum.

9) GARANTIE - Wir garantieren, daß unser Material den gegenwärtig gültigen Normen UNI-DIN-EN entspricht. Unsere Garantie beschränkt sich auf das Material 1. Wahl mit einer Toleranz von ca. 5% (fünf Prozent). Eine jegliche Garantie für Mängel wird für das Material 2. und 3. Wahl sowie für Stocks und Gelegenheitpartien, die immer unter der Bedingung "begutachtet und akzeptiert" verkauft werden, ausdrücklich ausgeschlossen. Eventuelle Reklamationen und Beanstandungen müssen vor der Verwendung des Materials und unter Beachtung der gesetzlichen Bestimmungen mittels Einschreiben ausschliesslich an unseren Verwaltungssitz in Castellarano (Reggio E.) gerichtet werden, andernfalls verfällt der Garantieanspruch. Nach Verwendung des Materials verfällt sowohl bei offensichtlichen als versteckten Mängeln der Anspruch auf die Garantie (Art. 1490 ital. Zivilgesetzbuch). Farbtonunterschiede können nicht als Materialfehler angesehen werden. Auf jeden Fall sieht unsere Garantie ausschliesslich den Ersatz des mangelhaften Materials vor und weitere Verpflichtungen sind ausgeschlossen. Auch bei eventuellen Beanstandungen des Materials ist der Käufer verpflichtet, die Ware innerhalb der vereinbarten Frist und auf die vereinbarte Weise gemäß Art. 7 zu bezahlen.

Jegliche Auseinandersetzung bezüglich der Ermittlung des Garantieanspruchs, der Schadensfestsetzung und Quantifizierung, die nicht auf gültlichem Wege unter den Parteien beigelegt werden kann wird dem nicht förmlichen Schiedsgerichtsverfahren eines Einzelschiedsrichters übergeben und soll gernaß den Bestimmungen der beim Centro Ceramico von Bologna eingerichteten Schiedsgerichtskammer bestellt und angewandt werden. Die Parteien erklären diese Verfahrensordnung bedingungslos und

unanfechtbar zu akzeptieren.

10) EXPORTVERBOT - Falls nicht anders vereinbart, ist es dem Käufer verboten, das von uns gelieferte Material zu exportieren oder es Personen oder Firmen zu übergeben, die das Material exportieren.

11) SCHIEDSGERICHTSKLAUSEL - Mit Ausnahme der Kontroversen, die mit der Zahlung des Kaufpreises und den diesbezüglichen auf dem Mahnweg oder durch normales Urteil ausgeführten Handlungen verbunden sind, die der Kompetenz des italienischen Gerichts unterstehen, wird jede weitere Kontroverse, die sich bezüglich des Abschlusses und/oder der Ausführung und/oder der Auflösung und/oder der Interpretation des gegenwärtigen Vertrages ergeben könnte, einem Kollegium von drei Schiedsrichtern übergeben, von denen einer von jeder der Parteien und der Dritte in gemeinsamem Einverständnis oder im Fall der Nichtübereinstimmung vom Vorsitzenden der Handelskammer von Reggio E. (Italien) auf Ersuchen der sorgfältigeren Partei ernannt wird. Die Partei, die beabsichtigt, das Schiedsgericht einzuberufen, ist dazu verpflichtet die andere Partei per Einschreiben zu benachrichtigen, indem sie die Ernennung des eigenen Schiedsrichters und dessen Annahme, mitteilt. Die andere Partei muß den eigenen Schiedsrichter innerhalb von fünfzehn Tagen, vom Datum des Empfangs des Einschreibens an, ernennen und diese Ernennung und die entsprechende Annahme innerhalb des angegebenen Zeitraums mitteilen. Im Mangelsfalle dessen kann die andere Partei die Ernennung des zweiten Schiedsrichters durch den Vorsitzen von der Handelskammer in Reggio E.(Italien) ersuchen. Die Schiedsrichter entscheiden nach dem Recht und unter Berücksichtigung des Prinzips des Widerspruchs. Der Schiedsspruch muß innerhalb von 90 Tagen, vom Datum der Annahme des letzten Schiedsrichters an, ausgesprochen werden. Das Schiedsgericht wird seinen Sitz in Reggio E. (Italien) haben.

12) EFFEKTIVE GÜLTIGKEIT JEDER BEDINGUNG - Die o.g. Allgemeinen Verkaufsbedingungen sind auf keinen Fall als Richtklauseln anzusehen, sondern sind effektiv und stellen getreu den Willen der Parteien dar.

droit, laissant toute autre initiative en suspens, de prétendre le paiement anticipé des fournitures restantes ou bien de retenir provisoirement en suspens ou définitivement résilié le contrat et d'annuler l'expédition d'autres commandes éventuellement en cours, sans que l'acheteur ne puisse avancer de droits de compensation, d'indemnisation ou autre.

7) SOLVE ET REPETE - Aucune exception, à part la nullité, l'annulabilité et la rescision du contrat ne peut être opposée par l'acquéreur dans le but de retarder ou d'éviter le paiement.

8) RÉSERVATION DE PROPRIÉTÉ - Au cas où le paiement, par des accords contractuels, doit être effectué - dans sa totalité ou en partie - après la livraison, les produits livrés restent notre propriété jusqu'à ce que le paiement intégral du montant ait été effectué.

9) GARANTIE - Nos matériaux sont garantis conformes aux Réglementations UNI-DIN-EN actuellement en vigueur. Notre garantie est limitée aux matériaux de 1er choix avec tolérance de 5% (cinq pour cent) environ. Toute garantie pour vices reste donc expressément exclue pour les matériaux de 2ème et de 3ème choix ou de stock qui, comme les lots occasionnels, s'entendent toujours comme vendus selon la formule "vu et plu". Les réclamations et les contestations éventuelles devront être notifiées, sous peine de déchéance, par lettre recommandée, exclusivement auprès de notre Siège Administratif à Castellarano (Reggio Emilia), avant la pose du matériau et de toute façon dans les délais imposés par la loi. La pose du matériau détermine la déchéance de l'action pour vices aussi bien manifestes que cachés, déterminant la renonciation implicite à la garantie, objet de l'art.1490 c.c. Les différences de tonalité ne peuvent être dénoncées comme vice du matériau. De toute façon, notre garantie ne comprend que la substitution du matériau trouvé défectueux, excluant toute obligation ultérieure et différente. Les contestations éventuelles sur le matériau ne donneront pas droit à l'acquéreur de suspendre ou de retarder dans sa totalité ou en partie le paiement dans les délais convenus, dans le respect de l'article précédent.

Chaque différend, concernant la vérification du droit à la garantie, à la détermination du dégât et à sa quantification, que ne puisse pas être réglée à l'arniable entre les parties, sera soumis à la Commission d'Arbitrage qui sera constituée et arbitrera second la règlement de la chambre d'Arbitrage Ceramique, domiciliée au Centre Ceramique de Bologna (Italy), que les deux parties déclarent accepter sans conditions et sans appel.

10) INTERDICTION D'EXPORTATION - A moins d'accords contraires, il est interdit à l'Acquéreur d'exporter les matériaux que nous lui avons fournis, ou de les céder à des Entreprises ou à des personnes qui en font l'objet d'exportation.

11) CLAUSE ARBITRAIRE - A l'exception des différends relatifs au paiement du prix et aux actions exercées par voie monitoire ou par jugement ordinaire, qui restent de compétence des autorités juridiques italiennes, toute autre controverse qui devrait surgir relativement et/ou exécution et/ou résolution et/ou interprétation du présent contrat sera transmise à un Collège de trois arbitres. Chaque partie en nomme un et le troisième est nommé d'un commun accord et en cas de désaccord par le Président de la C.C.I.A.A. (Chambre de Commerce) de Reggio E. (Italie) sur demande de la partie la plus diligente. La partie qui a l'intention de commencer l'arbitrage doit communiquer à l'autre partie par lettre recommandée contenant la nomination du propre arbitre et son acceptation. L'autre partie doit nommer son propre arbitre dans le délai de quinze jours à partir de la date de réception de la lettre recommandée, en communiquant cette nomination et la relative acceptation avant le délai indiqué. A défaut l'autre partie pourra demander la nomination du deuxième arbitre au le Président de la C.C.I.A.A. (Chambre de Commerce) de Reggio E. (Italie). Les arbitres décident suivant le droit et dans le respect du principe du jugement contradictoire. Le jugement devra être délibéré dans le délai de 90 jours à partir de la date d'acceptation du dernier arbitre. L'arbitrage a comme siège Reggio E. (Italie).

12) VALIDITÉ DE CHAQUE CONDITION - Les conditions générales de vente mentionnées ci-dessus ne doivent absolument pas s'entendre comme pures clauses de style. Elle sont réelles et représentent fidèlement la volonté juridique des parties.

CREDITS

Art direction: Marco Porpora, Mirco Natalini, Marketing Ariostea
Graphic project: up-comunicazione.com

Edition n°1 - September 2015
Printed in Italy

Ariostea all right reserved

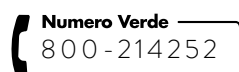

info@ariostea.it

CODE: CAT01850

WWW.ARIOSTEA.IT ARIOSTEA_via Cimabue 20 42014 Castellarano Reggio Emilia - Italy - Tel. +39 0536 816811 - Fax +39 0536 816858 (Export) - Fax +39 0536 816838 (Italy)