

# RAK-JOY UNO



**RAK**  
CERAMICS

## ICONS

### APPLICATION

Applicazione | Application | Aplicación | Anwendung | Способ Применения



#### WALL HUNG VANITY UNIT

Mobile sospeso  
Meuble suspendu  
Mueble suspendido  
Waschtisch, wandhängend  
Подвесная тумба



#### WALL HUNG TALL STORAGE UNIT

Colonna sospesa  
Colonne grande hauteur suspendue  
Armario alto de pared  
Hoher Aufbewahrungsschrank, wandhängend  
Подвесной пенал



#### WALL HUNG MIRROR CABINET

Specchio contenitivo sospeso  
Armoire toilette  
Espejo contenedor de pared  
Wandspiegelschrank  
Подвесной шкаф с зеркалом



#### WALL HUNG MIRROR

Specchio a parete  
Miroir  
Espejo a pared  
Wandspiegel  
Подвесное зеркало



#### COUNTER TOP WASH BASIN

Lavabo da appoggio  
Lavabo sur comptoir  
Lavabo De Apoio  
Aufgesetztes Waschbecken  
накладная раковина на столешницу



#### DROP IN WASH BASIN

Incasso  
A encastre  
lavabo de encastre  
Einbau  
Встраиваемая раковина



#### COUNTER TOP SLAB+BOWL

Piano d'appoggio + ciotola  
Plan + vasque à poser  
Encimera+lavabo de apoyo  
Platte + Aufsatzwaschbecken  
Цельнолитая столешница + чаша

## TECHNICAL INFORMATION

Informazioni Tecniche  
Informations Techniques  
Información Técnica  
Technische Informationen  
Техническая информация

### DETAILS

Dettagli | Détails | Detalles | Details | Характеристики



#### SOFT CLOSE HINGES

Cerniere a chiusura rallentata  
Charnières amorties  
Bisagras amortiguadas  
Scharnier mit integrierter Dämpfung  
Плавно закрывающиеся петли



#### ADJUSTABLE BRACKETS

Fissaggi regolabili  
Supports réglables  
Soportes ajustables  
Uerstellbare Befestigungsbügel  
Регулируемые кронштейны



#### SOFT CLOSE DRAWER RUNNERS

Guide a chiusura rallentata  
Coulisses avec système de fermeture progressive  
Guías cajones con sistema soft close  
Läufer mit integrierter Dämpfung  
Плавное закрытие ящиков



#### FULL EXTRACTION DRAWERS

Cassetti ad estrazione completa  
Tiroirs d'extraction complets  
Cajones completamente extraíbles  
Voll auszug schubladen  
Полновыдвижные ящики



#### J-PULL FRONTALS

Frontali con maniglia integrata J-pull  
Prise de main J-pull  
Tirador con forma a J  
J-Pull Frontals  
J-образный вырез на торце



#### ADJUSTABLE GLASS SHELVING

Ripiani regolabili in vetro  
Étagères en verre réglable  
Estantes de cristal ajustables  
Verstellbare Glasregale  
Регулируемая стеклянная полка



#### REVERSIBLE

Reversibile  
Réversible  
Reversible  
Reversibel  
Реверсионный



#### DRAWER ORGANISERS

Organizzatori per cassetto  
Organisateurs de tiroirs  
Organizadores De Cajón  
Schubladeneinteiler  
Выдвижные ячейки ящика



#### DE-MISTER

Anti-appannamento  
Système antibuée  
Espejo con sistema desempañador  
Entnebler  
Защита от запотевания



#### WITHSTANDING HEAVY LOADS 50KG

Supporta carichi pesanti 50kg  
Résistant les charges lourdes 50kg  
Soporta cargas pesadas de 50 kg  
Widersteht starker beanspruchung 50kg  
Выдерживает большие нагрузки 50 кг



#### WITHSTANDING HEAVY LOADS 150KG

Supporta carichi pesanti 150kg  
Résistant les charges lourdes 150kg  
Soporta cargas pesadas de 150 kg  
Widersteht starker beanspruchung 150kg  
Выдерживает большие нагрузки 150 кг



#### FSC® CERTIFICATION WOODEN MATERIALS ARE FSC CERTIFIED.

I materiali in legno sono certificati FSC.  
Les matériaux en bois sont certifiés FSC.  
Certificación Fsc® Materiales De Madera Certificados Fsc.  
Die Holzmaterialien sind FSC-zertifiziert.  
Древесные материалы, сертифицированные FSC.



#### WATERPROOF

Resistente all'acqua  
Imperméable  
Resistente al agua  
Wasserdicht  
Водонепроницаемость

## RAK-JOY UNO

*One like no one.*

Functional, elegant, spacious and modular, RAK-Joy Uno is the natural evolution of the successful story of RAK-Joy. A minimalist design that will enhance the style of your bathroom, by giving you a one-drawer only contemporary solution. RAK-Joy Uno is the new RAK Ceramics bathroom furniture range, designed to move the style of your bathroom on to a higher level. Innovative, high-quality and with exceptional details, RAK-Joy Uno is also available in 5 different finishes. Fully compatible with the washbasins , suitable for the existing RAK-Joy range, it can be combined with the new RAK-Joy mirrors and with all the RAK Ceramics countertop solutions.



Funzionale, elegante, spazioso e modulare, RAK-Joy Uno è la naturale evoluzione della storia di successo di RAK-Joy. Funzionale, elegante, spazioso e modulare, RAK-Joy Uno è la naturale evoluzione della storia di successo di RAK-Joy. RAK-Joy Uno è la nuova serie di mobili bagno RAK Ceramics, progettati per l'evoluzione del tuo bagno. Innovativo e ricco di dettagli di alta qualità, RAK-Joy Uno è disponibile in 5 diverse finiture. Compatibile con i lavabi attualmente disponibili per la gamma RAK-Joy, può anche essere combinato con gli specchi e con tutte le soluzioni Countertop RAK Ceramics.



Fonctionnel, élégant, spacieux et modulaire, RAK-Joy Uno est l'évolution naturelle de l'histoire de succès de RAK-Joy. Un design minimaliste, en mesure d'exalter le style de votre salle de bains, en offrant une solution contemporaine avec un seul tiroir. RAK-Joy Uno est la nouvelle série de meubles de salle de bains RAK Ceramics, projetés pour l'évolution de votre salle de bains. Innovateur et riche en détails de haute qualité, RAK-Joy Uno est disponible en 5 diverses finitions. Compatible avec les lavabos actuellement disponibles pour la gamme RAK-Joy, il peut également être combiné avec des miroirs et toutes les solutions countertop RAK Ceramics.



Funcional, elegante, espacioso y modular, RAK-Joy Uno es la evolución natural de la historia de éxito de RAK-Joy. Un diseño minimalista, capaz de realzar el estilo de su baño, ofreciendo una solución contemporánea con un solo cajón. RAK-Joy Uno es la nueva serie de muebles de baño RAK Ceramics, diseñada para la evolución de su baño. Innovador y lleno de detalles de alta calidad, RAK-Joy Uno está disponible en 5 acabados diferentes. Compatible con los lavabos disponibles actualmente para la gama RAK-Joy, también puede combinarse con espejos y todas las soluciones Countertop RAK Ceramics.



Funktionell, elegant, geräumig und modular, stellt RAK-Joy Uno die natürliche Entwicklung der Erfolgsgeschichte von RAK-Joy dar. Ein minimalistisches Design, das in der Lage ist, den Stil Ihres Badezimmers zu betonen, indem es eine zeitgenössische Ein-Schubfach-Lösung bietet. RAK-Joy ist die neue Serie an Badezimmermöbeln von RAK Ceramics, die für die Entwicklung Ihres Badezimmers entworfen wurden. Innovativ und reich an hochqualitativen Details, präsentiert sich RAK-Joy Uno in 5 verschiedenen Oberflächenbeschaffheiten. Kompatibel mit den aktuell verfügbaren Waschbecken des Sortiments RAK-Joy, lässt es sich ebenfalls mit Spiegeln sowie allen Countertop-Lösungen RAK Ceramics kombinieren.



Функциональная, эlegantная, просторная и модульная линия мебели RAK-Joy Uno - это результат эволюции успешной линии мебели RAK-Joy. Минималистский дизайн, который улучшит стиль вашей ванной комнаты, предоставляя современное решение с одним ящиком RAK-Joy Uno - это новая линия мебели для ванной комнаты от RAK Ceramics, разработанная для того, чтобы усовершенствовать стиль вашей ванной комнаты, достичь более высокого уровня. Инновационная, высококачественная и с исключительными деталями линия 5 мебели RAK-Joy Uno доступна в различных отделках. Безупречная совместимость с раковинами, из существующей линейки RAK-Joy, и со всеми столешницами RAK Ceramics, может быть также дополнена новыми RAK-Joy зеркалами.

### LIGHTING

Illuminazione | Eclairage | Encendiendo | Beleuchtung | Освещение



#### LED LIGHT

LED Luce  
LED Lumière  
LUZ LED  
LED Licht  
Светодиодная (led) подсветка



#### USB RECHARGEABLE

Ricaricabile via USB  
USB RECHARGEABLE  
USB rechargeable  
USB wiederaufladbar  
Заряжается через usb



#### MAINS POWERED

Alimentazione da rete  
Alimentation secteur  
Alimentacion de red  
Netz betrieben  
Питание от сети



#### MOTION SENSOR

Sensore di movimento  
Capteur de mouvement  
Sensor De Movimiento  
Bewegungssensor  
Датчик движения



#### TOUCHLESS ACTIVATION

Attivazione a sfioro  
Activation sans touche  
Activación sin contacto  
berührungslose Aktivierung  
Бесконтактная активация



#### IP44

IP44  
IP44  
IP44  
IP44  
IP44

All ceramic cistern codes refer to bottom inlet version; all washbasin codes refer to one tap hole version, unless differently specified.

Tutti i codici per le cisterne si riferiscono alla versione con carico dal basso; tutti i codici dei lavabi si riferiscono alla versione con un foro, se non diversamente specificato

l'entrée de l'eau de tous les réservoirs pour nos wc monobloc ets positionnée dans la partie inférieure; tous nos lavabos sont prévus avec un seul trou pour les robinets (sauf specification différente)

Alle Zulaufe für den Spülkasten befinden sich im unteren Bereichs des WCs. Alle Kodes der Waschbecken beziehen sich auf die Version mit einem Loch, falls nicht anders angegeben.

Если иное не указано, все коды для керамического бачка относятся к варианту с впускным отверстием снизу; все коды для раковины относятся к варианту с одним отверстием для крана.







 W 80 x D 3 x H 80CM  
JOYMR08000LED

 CM 101  
PREOC10347104A

 104

 W 100 x D 46 x H 40CM  
UNOWH0100UGY

 PWH







 60 CM  
JOYOS040MGY

 MGY

 270CM = W 90 x D 31 x H 307CM  
USSAS0004504 x3







-  W 80 x D 3 x H 80CM  
JOYMR08000LED
-  101 x 46 CM  
DESWB10101AWHA
-  W 100 x D 46 x H 40CM  
UNOWH100MOK
-  MOK
-  60 CM  
JOYOS040MGY
-  MGY





 W 120 x D 3 x H 68CM  
JOYMR12068LED

 61 x 46 CM  
JOYDI06101WH

 W 60 x D 46 x H 40CM  
UNOWH060UGY

 UGY

 60 CM  
JOYOS040MGY

 MGY

 180CM = W 90 x D 31 x H 307CM  
USSAS0004504 x2





W 100 x D 3 x H 100CM  
JOYMR10000LED

CM 101  
DESWB10101AWHA

W 100 x D 46 x H 60CM  
UNOWH100SOK



W 30 x D 23 x H 120CM  
JOYTS120SOK





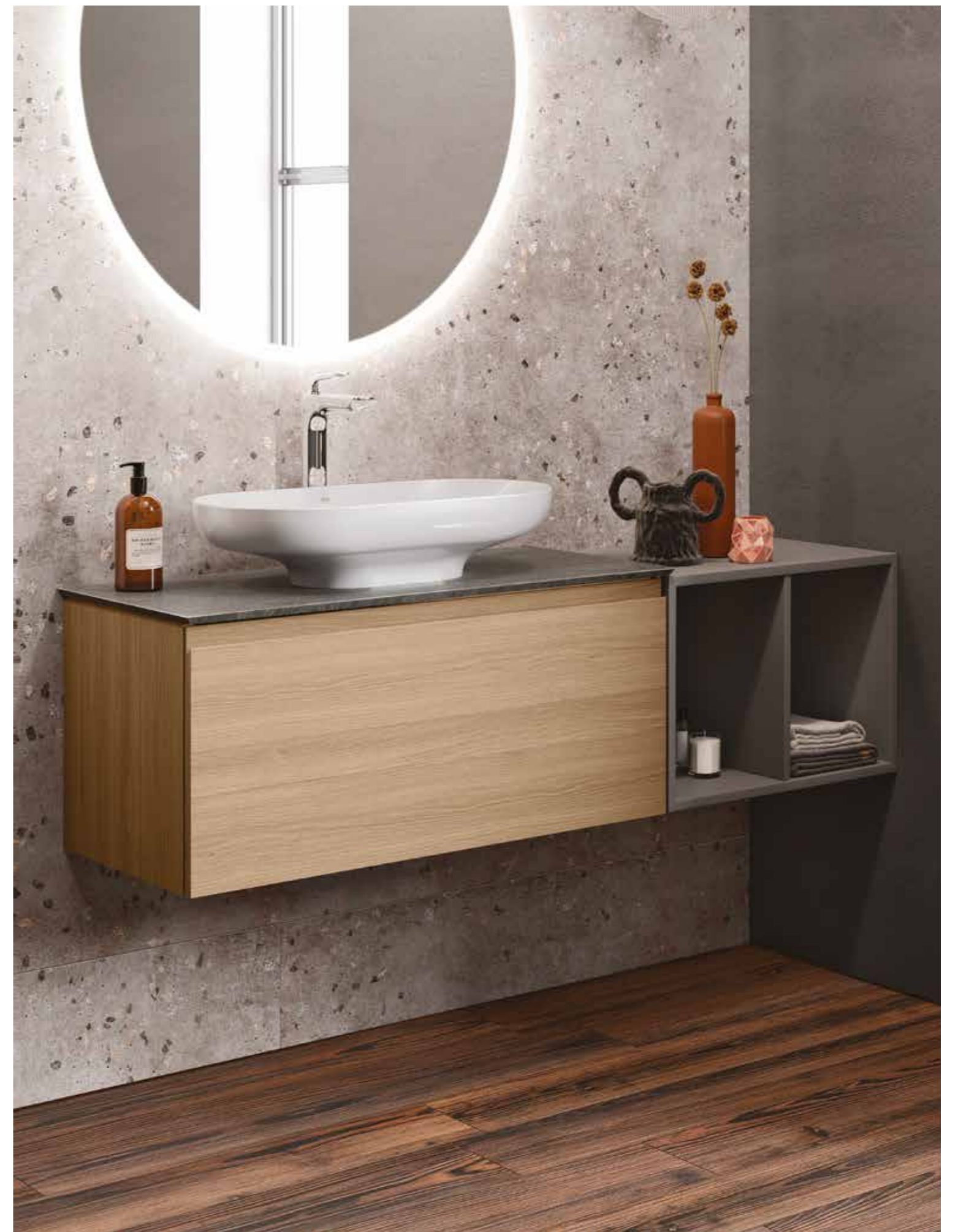









## Raw materials, latest technology and manufacture

RAK Ceramics is internationally recognized for the high quality of its sanitary ceramics. This quality comes from carefully selected premium raw materials that ensure a perfect finish of the products. For RAK-JOY collections we have applied the same high standards; and in the production skilled craftsmen work in harmony with the latest robot technology for the furniture manufacturing. Every phase of the RAK-JOY production process counts on strict quality control procedures. The leadership in the GCC Region and the strong presence in several other international markets reflects our everyday efforts. Our internal norms comply and exceed the international requirements in terms of quality and performance.



## From responsible sources FSC® certified

The RAK-JOY wooden furniture collection respects the environment and the life of the furniture itself. All particleboard and MDF used in the construction of this striking furniture collection comes from responsible sources FSC certified, respecting the forests, the people and wildlife who call them home.

For more information: [www.fsc.org](http://www.fsc.org)

Furthermore, all external LAMILAK and TECHWOOD surfaces are made from recyclable PET or PP materials. Polyurethane glue has been used to seal all furniture edges, allowing no water ingress. RAK-JOY has been subjected to the Fira Level 5 water ingress tests, where external panels are subjected to 10 water submersion cycles with no degradation to the panels. The furniture also meets EN 14749 and BS 4875-7 structural and performance standards. Doors and drawers are fitted with lifetime guaranteed Blum hinges and drawer runners – the installers choice to ‘fit and forget’. There is also the option to upgrade RAK-JOY with ambient USB re-chargeable lighting and de-misting mirrors. Internal drawer accessories complete the look. RAK-JOY, the bathroom furniture choice for style and functionality.



FSC® N002784

### WATER INGRESS TEST

All external panels including doors and drawers are subjected to 10 cycles over 5 days to water ingress tests and pass against no swelling or degradation of the panels.

Submerge 15cm of frontal in water  
Twice a day For 5 days

### PRODUCT BENEFITS

- blum** Drawer runners and hinges with lifetime warranty
- 150kg Vanity hanging bracket
- 50kg Tall storage unit and mirror cabinet hanging bracket

### SUSTAINABILITY AND QUALITY

- FSC** Wooden products are made of material from responsible sources FSC® certified. [www.fsc.org](http://www.fsc.org) FSC® N002784
- TUV NORD** Quality Management system certified for facilities, people, training, services and equipment. ISO 9001



## MATERIALS

Materiali | Matériaux | Materiales | Materialien | Материалы

### LAMILAK

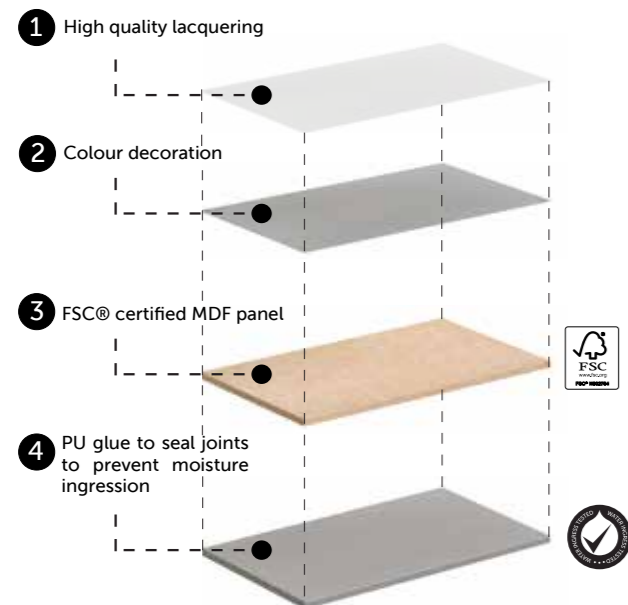

LAMILAK is the new gloss material that exudes consistent quality and performance. The brilliant high gloss shine gives a striking smooth surface final appearance. To protect the environment, LAMILAK is produced from PET recyclable material.

LAMILAK è il nuovo materiale a finitura lucida dalla qualità e prestazioni costanti. L'elevata brillantezza della finitura conferisce un aspetto finale di superficie estremamente liscia e specchiante. Per proteggere l'ambiente, LAMILAK è prodotto con materiale riciclabile PET.

LAMILAK est le nouveau matériau brillant qui respire la qualité et la performance constante. La finition à haute brillance donne une apparence finale de surface lisse et frappante. Pour protéger l'environnement, LAMILAK est fabriqué à partir de matériaux recyclable à base de PET.

LAMILAK es el nuevo material brillante, que rezuma calidad y rendimiento sin interrupciones. El gran esplendor brillante regala una apariencia final superficial uniforme impresionante. LAMILAK se fabrica a partir de material reciclable PET para proteger el medio ambiente.

LAMILAK ist das neue Glanzmaterial, das konsistente Qualität und Leistung ausstrahlt. Der strahlende Hochglanz verleiht der Oberfläche eine auffällige glatte Oberfläche. Zum Schutz der Umwelt wird LAMILAK aus recyceltem PET-Material hergestellt.

LAMILAK – это новый глянцевый материал, обладающий устойчивым качеством и характеристиками. Блестящее глянцевое сияние придает поверхности потрясающе гладкий вид. Для защиты окружающей среды LAMILAK изготавливается из перерабатываемого полиэтилена.

### TECHWOOD

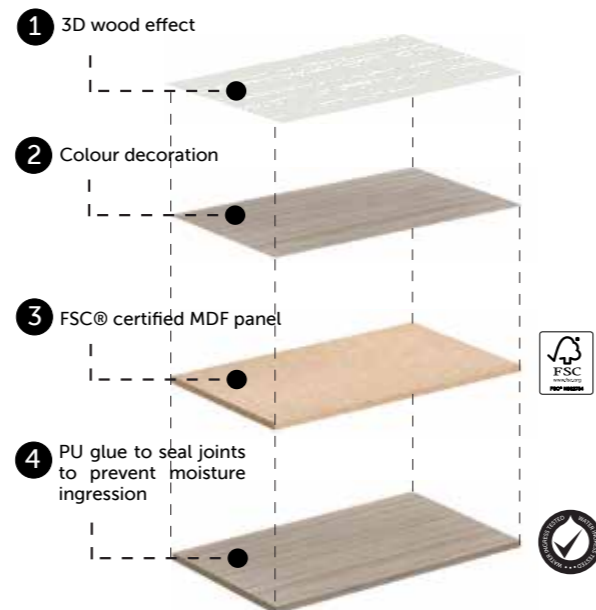

TECHWOOD is the new wood effect material that gives the tactile impression of real wood. Revel in the touch and feel of its vibrant texture. To protect the environment, TECHWOOD is produced from polypropylene recyclable material.

TECHWOOD è il nuovo materiale a finitura legno che conferisce la sensazione tattile di vero legno. Accarezza la superficie e prova la sensazione della sua vibrante venatura. Per proteggere l'ambiente, TECHWOOD è prodotto con materiale riciclabile in polipropilene.

TECHWOOD est le nouveau matériau à effet bois qui donne l'impression tactile du vrai bois. Revel dans le toucher et la sensation de sa texture dynamique. Pour protéger l'environnement, TECHWOOD est fabriqué à partir de matériaux recyclable en polypropylène.

TECHWOOD es el nuevo material imitación de madera, que regala la sensación táctil de madera auténtica. Disfrute al tocarlo y sienta su textura vibrante. TECHWOOD se fabrica a partir de material reciclable PET para proteger el medio ambiente.

TECHWOOD ist das neue Holz-Effekt-Material, das den fühlbaren Eindruck von echtem Holz vermittelt. Genießen Sie die Berührung und das Gefühl seiner lebendigen Textur. Um die Umwelt zu schützen, wird TECHWOOD aus recyceltem Polypropylen hergestellt.

TECHWOOD – это новый материал с эффектом древесины, дающий тактильное ощущение натурального дерева. Насладитесь его живой текстурой! Для защиты окружающей среды TECHWOOD изготавливается из перерабатываемого полипропилена.

## COLOURS AND FINISHES

Finiture E Colori | Finitures Et Couleurs | Colores y acabados | Oberflächen Und Farben | Цвета И Отделка

PURE WHITE  
(LAMILAK)

URBAN GREY  
(LAMILAK)

SCANDINAVIAN OAK  
(TECHWOOD)

GREY ELM  
(TECHWOOD)

MOKA WALNUT  
(TECHWOOD)

MATT GREY (only for Open Storage Units)  
(LAMILAK)

ANTHRACITE  
(INTERNAL FINISH)



## PRODUCT BENEFITS

Vantaggi Del Prodotto | Avantages Du Produit | Produkt Vorteile | преимущества продукта

### VANITIES & TALL CABINET

Mobili sospesi | Meubles suspendus | Muebles lavabos suspendidos y columnas suspendidas | Waschtisch, wandhängend | шкафик под раковиной и высокий подвесной шкаф



**FSC® CERTIFICATION**  
WOODEN MATRERIALS ARE FSC CERTIFIED.  
I materiali in legno sono certificati FSC.  
Les matériaux en bois sont certifiés FSC.  
Certificación Fsc® Materiales De Madera Certificados Fsc.  
Die Holzmaterialien sind FSC-zertifiziert.  
Деревянные материалы, сертифицированные FSC.



**WATERPROOF**  
Resistente all'acqua  
Imperméable  
Resistente al agua  
Wasserdicht  
Водонепроницаемость



**WITHSTANDING HEAVY LOADS 50KG**  
Supporta carichi pesanti 50kg  
Résistant les charges lourdes 50kg  
Soporta cargas pesadas de 50 Kg  
Widersteht starker beanspruchung 50kg  
Выдерживает большие нагрузки 50 кг



**WITHSTANDING HEAVY LOADS 150KG**  
Supporta carichi pesanti 150kg  
Résistant les charges lourdes 150kg  
Soporta cargas pesadas de 150 Kg  
Widersteht starker beanspruchung 150kg  
Выдерживает большие нагрузки 150 кг



**J-PULL FRONTALS**  
Frontali con maniglia integrata J-pull  
Prise de main J-pull  
Tirador con forma a J  
J-Pull Frontals  
J-образный вырез на торце



**FULL EXTRACTION DRAWERS**  
Cassetti ad estrazione completa  
Tiroirs d'extraction complets  
Cajones completamente extraíbles  
Voll auszug schubladen  
Полновыдвижные ящики



**SOFT CLOSE DRAWER RUNNERS**  
Guide a chiusura rallentata  
Coulisses avec système de fermeture progressive  
Guías cajones con sistema soft close  
Läufer mit integrierter Dämpfung  
Плавное закрытие ящиков



**SOFT CLOSE HINGES**  
Cerniere a chiusura rallentata  
Charnières amorties  
Bisagras amortiguadas  
Scharnier mit integrierter Dämpfung  
Плавно закрывающиеся петли



**ADJUSTABLE GLASS SHELVING**  
Ripiani regolabili in vetro  
Étagère en verre réglable  
Estantes de cristal ajustables  
Verstellbare Glasregale  
Регулируемая стеклянная полка



**ADJUSTABLE BRACKETS**  
Fissaggi regolabili  
Supports réglables  
Soportes ajustables  
Uerstellbare Befestigungsbügel  
Регулируемые кронштейны

## PRODUCT BENEFITS

Vantaggi Del Prodotto | Avantages Du Produit | Ventajas Del Producto | Produkt Vorteile | преимущества продукта

### MIRRORS

Specchi e specchi contenitivi | Miroirs et armoires toilette | Spiegel & Schränke | зеркала

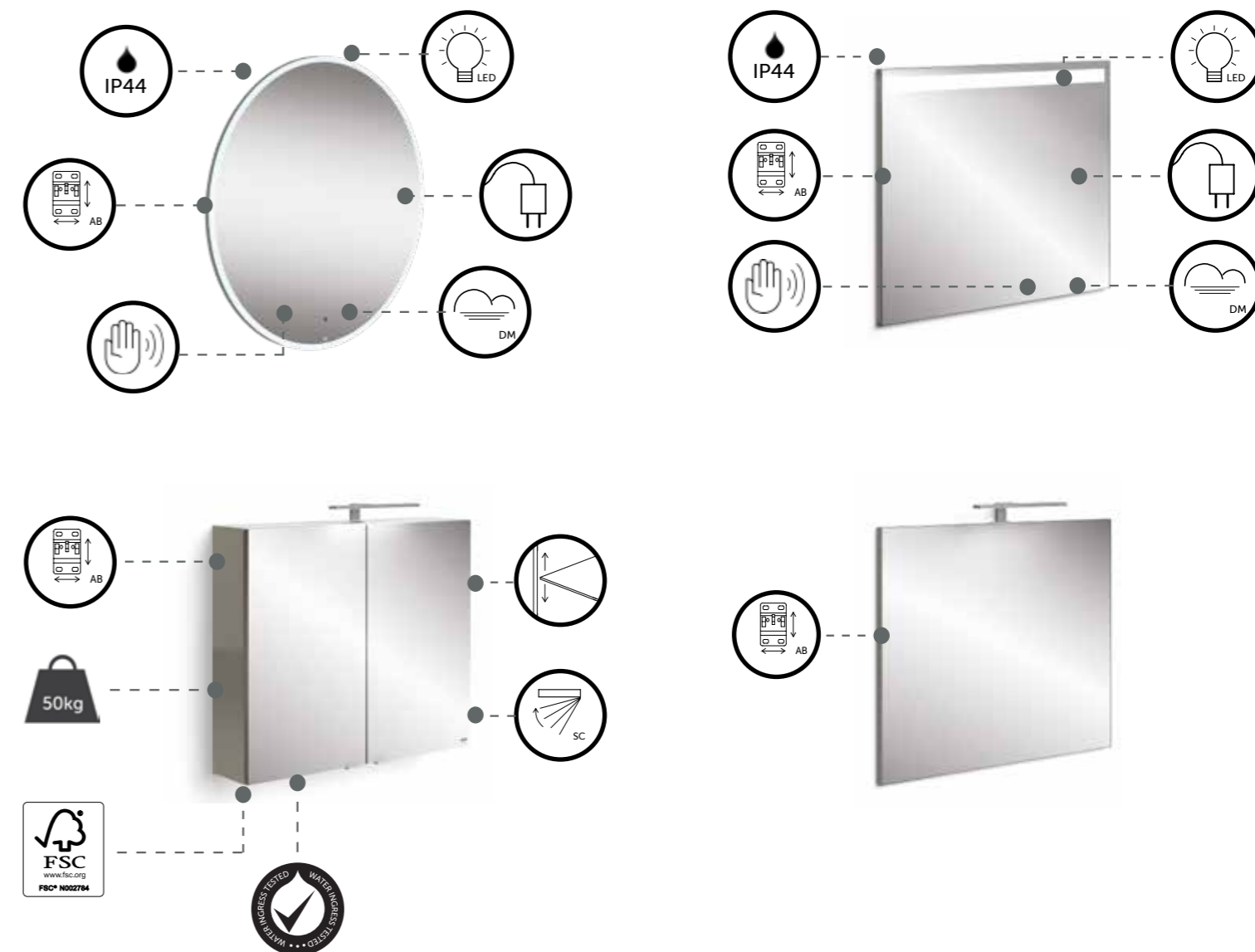

**MAINS POWERED**  
Alimentazione da rete  
Alimentation secteur  
Netz betrieben  
Питание от сети



**DE-MISTER**  
Anti-appannamento  
Système antibuée  
Espejo Con Sistema Desempañador  
Entnebler  
Защита от запотевания



**TOUCHLESS ACTIVATION**  
Attivazione a sfioro  
Activation sans touche  
berührungslose Aktivierung  
Бесконтактная активация



**MOTION SENSOR**  
Sensore di movimento  
Capteur de mouvement  
Sensor de movimiento  
Bewegungssensor  
Датчик движения



**USB RECHARGEABLE**  
Ricaricabile via USB  
USB rechargeable  
USB recargable  
USB wiederaufladbar  
Заряжается через usb



**REVERSIBLE**  
Reversible  
Réversible  
Reversible  
Реверсионный



**LED LIGHT**  
LED Luce  
LED Lumière  
LED Licht  
Светодиодная (led) подсветка



**IP44**  
IP44  
IP44  
IP44  
IP44  
IP44



# PRODUCT LIST

**WALL HUNG FURNITURE** | Mobili sospesi | Meubles suspendus | Muebles suspendidos | Waschtisch, wandhängend | Навесная мебель



W 40 x D 22 x H 60CM



W 60 x D 46 x H 40CM

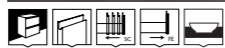

W 80 x D 46 x H 40CM

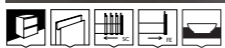

W 100 x D 46 x H 40CM



120CM - 2x W 60CM Units



160CM - 2x W 80CM Units

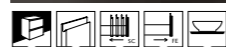

200CM - 2x W 100CM Units



**OPEN STORAGE UNITS** | Vani a vista | Unités de stockage ouvertes | Unidades de almacenamiento abierto | Offene Lagerungseinheiten | Открытые ячейки



60 CM



**TALL CABINET UNIT** | Colonna sospesa | Colonne Suspendue | Columna suspendida | Hochschrank | Высокий подвесной шкаф



W 30 x D 23 x H 120CM



**TOP MOUNTED T-BAR LIGHT**

| Luce "a T" montabile in alto | Spot en t-bar montée sur le dessus | Barra de luz en forma de t con montaje superior | T-bar Aufsatzlicht | T-образная подсветка с верхним креплением

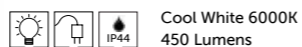

Cool White 6000K  
450 Lumens

**USB RECHARGABLE LIGHT**

| Luce ricaricabile del USB | Lumière USB rechargeable | Luz recargable USB | USB rechargeable Licht | Заряжаемая от USB подсветка

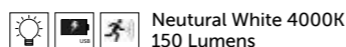

Neutral White 4000K  
150 Lumens

**MIRRORS** | Specchi | Mirrors | Espejos | Spiegel | Зеркала

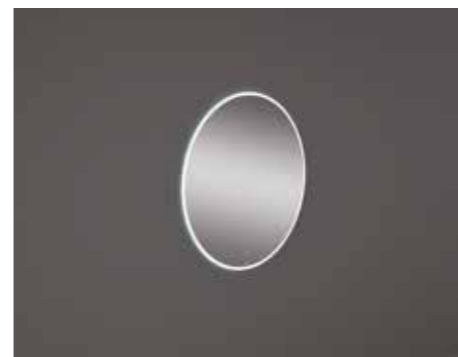

W 60 x D 3 x H 60CM  
Cool White 6000K  
980 Lumens



W 80 x D 3 x H 80CM  
Cool White 6000K  
1350 Lumens



W 100 x D 3 x H 100CM  
Cool White 6000K  
1700 Lumens

**MIRRORS & CABINETS** | Specchi e specchi contenitivi | Mirrors et armoires toilette | Espejos y armarios | Spiegel & Schränke | Зеркала и шкафчики



W 40 x D 18 x H 68CM



W 60 x D 18 x H 68CM



W 80 x D 18 x H 68CM



W 100 x D 18 x H 68CM



120CM - 2x W 60CM Units



W 40 x D 3 x H 68CM



W 60 x D 3 x H 68CM



W 80 x D 3 x H 68CM



W 100 x D 3 x H 68CM



W 120 x D 3 x H 68CM



W 40 x D 3 x H 68CM



W 60 x D 3 x H 68CM



W 80 x D 3 x H 68CM



W 100 x D 3 x H 68CM



W 120 x D 3 x H 68CM



DROP IN WASH BASINS | Lavabi da incasso | Plan vasque | Drop-in Waschbecken | Встраиваемая раковина



41 x 23 CM



61 x 46 CM



81 x 46 CM



101 x 46 CM



121 x 46 CM



61 x 46 CM



81 x 46 CM



101 x 46 CM



121 x 46 CM



FOR VANITY SPACE SAVING

RAK-JOY + RAK-PRECIOUS

RAK Precious drop in washbasins and countertop solutions can be combined with your favorite RAK-Joy bathroom vanity. RAK-Precious are available in 6 different finishes and colors, perfectly compatible with RAK-Joy.



I lavabi da incasso RAK-Precious ed i piani d'appoggio possono essere combinati al tuo mobile bagno RAK-Joy preferito. La gamma RAK-Joy e' disponibile in 6 diverse finiture, perfettamente compatibili con colori e finiture RAK-Precious.



Les lavabos à encastrer de RAK-Precious et les plans de toilette peuvent être combinés avec votre meuble de salle de bains préféré de RAK-Joy. La gamme RAK-Joy est disponible en 6 finitures différentes, parfaitement compatibles avec les couleurs et les finitures de RAK-Precious.



Soluciones de lavabos sobre encimera y lavabos de encimera RAK Precious se pueden combinar con su mueble de lavabo suspendido favorito RAK-Joy. Los modelos RAK-Precious están disponibles en 6 acabados y colores distintos, perfectamente compatibles con RAK-Joy.



Die Einbauwaschbecken von RAK-Precious sowie die Auflageflächen können mit Ihrem bevorzugten Badezimmermöbelstück kombiniert werden. Die gesamte Bandbreite von RAK-Joy ist in 6 verschiedenen Oberflächen verfügbar, die mit den Farben und Oberflächen von RAK-Precious bestens kompatibel sind.



Встраиваемые и монтирующиеся на столешницу раковины от RAK-Precious можно комбинировать с наиболее понравившейся тумбой из коллекции RAK-Joy. На выбор предлагается 6 различных отделки тумб RAK-Joy, которые идеально сочетаются с цветовой гаммой и отделочными материалами компании RAK-Precious.





UNIVERSAL SHELVING UNITS

Scaffali Universali | Unités De Rayonnage Universelles | Universales Regal Einheiten | Unidades De Estante Universales | Универсальные Установки



W 60CM



504



W 60 x H 60CM



504



W 60 x H 180CM



504



W 90 x D 31 x H 307CM



504



W 90 x D 31 x H 307CM



504

Shelving is not only practical: it can also be fully part of your bathroom design. Contemporary, sophisticated and easy to be installed, RAK-Joy shelving units help you style your bathroom, with a creative and multifunctional furnishing solutions to meet your needs and express your imagination. The unit is equipped with an interlocking system so that you can hook the accessories without screwing them into the structure. The bifacial bookcase is a creative partition that works as furnishing accessory and dividing wall. Find a new solutions to separate your rooms, store your objects and complete your bathroom with style.



Le mensole non sono solo pratiche: possono anche essere parte integrante del design del tuo bagno. Contemporanei, sofisticati e facili da installare, gli scaffali RAK-Joy ti aiutano a dare stile al tuo bagno, con soluzioni d'arredo creative e multifunzionali per soddisfare le tue esigenze ed esprimere la tua fantasia. Le unità sono dotate di un sistema ad incastro per poter agganciare gli accessori senza avvitari alla struttura. La libreria bifacciale è un divisorio creativo che funge da complemento d'arredo e parete divisoria. Trova nuove soluzioni per separare i tuoi spazi, riporre i tuoi oggetti e completare il tuo bagno con stile.



Les surfaces de travail ne sont pas seulement pratiques, mais peuvent également devenir une partie intégrante de votre salle de bains. Contemporaines, sophistiquées et faciles à installer, les étagères de RAK-Joy vous aident à conférer du style à votre salle de bains, par des solutions d'aménagement créatives et multifonctionnelles, qui satisfont vos exigences et expriment votre fantaisie. Les unités sont dotées d'un système de fixation, pour y joindre les accessoires, sans avoir besoin de les visser à la structure. La bibliothèque bifaciale est un élément de séparation créatif qui sert à la fois de meuble et de mur de séparation. Trouvez de nouvelles solutions, pour séparer vos espaces, déposer vos objets et compléter avec style votre salle de bains.



Los estantes no solo son prácticos, también pueden ser una parte integral del diseño de su baño. Contemporáneos, sofisticados y fáciles de instalar, los estantes RAK-Joy te ayudan a darle estilo a tu baño, con soluciones de decoración creativas y multifuncionales para satisfacer tus necesidades y expresar tu imaginación. Las unidades están equipadas con un sistema de enclavamiento para poder enganchar los accesorios sin atornillarlos a la estructura. La estantería de doble cara es un divisor creativo que sirve como mueble y pared divisoria. Encuentra nuevas soluciones para separar tus espacios, almacenar tus artículos y completar tu baño con estilo.



Ablagen sind nicht nur praktisch, sie können auch zu einem festen Bestandteil Ihres Badezimmerdesigns werden. Zeitgenössisch, anspruchsvoll und einfach zu installieren - die Regale von RAK-Joy helfen Ihnen dabei, Ihrem Badezimmer Stil zu verleihen, durch kreative und multifunktionale Einrichtungslösungen, die Ihre Wünsche erfüllen und Ihre Fantasie zum Ausdruck bringen. Die Einheiten sind mit einem Spannsystem ausgestattet, um Accessoires anzuhängen, ohne sie an die Struktur anzuschrauben. Das beidseitige Bücherregal ist ein kreatives Trennelement, das gleichzeitig als Möbelstück und als Trennwand fungiert. Finden Sie neue Lösungen, um Ihre Räume zu trennen, Ihre Gegenstände abzulagern und Ihr Badezimmer stilvoll zu ergänzen.



Полки выполняют не только практическую функцию – они также могут в полной мере стать частью дизайна вашей ванной комнаты. Современные, тщательно продуманные и простые в установке полочные модули RAK-Joy помогут вам создать дизайн ванной комнаты благодаря креативным и многофункциональным решениям для мебелировки, которые отвечают вашим потребностям и дают возможность воплотить в жизнь ваши фантазии. Данный модуль оснащен системой сцепления, позволяющей подвешивать аксессуары без необходимости крепить их винтами к конструкции. Двусторонний шкаф представляет собой креативную перегородку и выполняет функцию мебельного аксессуара, а также служит для разделения стены. Находите новые решения для разделения ваших комнат, хранения вещей и создания стильного образа вашей ванной комнаты.





WALL HUNG VANITY UNITS

Mobili sospesi | Meubles suspendus | Mueble de baño suspendido | Waschtisch wandhängend | Подвесная тумба



W 40 x D 22 x H 60CM  
JOYWH040UGY



W 60 x D 46 x H 40CM  
UNOWH060UGY

Space saving bottle trap required BTRWBPPR022



W 80 x D 46 x H 40CM  
UNOWH080UGY

Space saving bottle trap required BTRWBPPR022

Measurements | Misure | Dimensions | Medidas | Abmessungen | Размеры

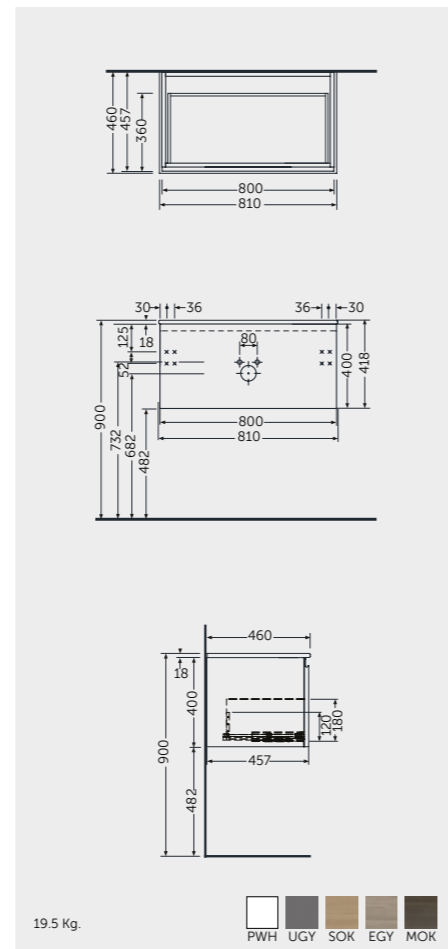
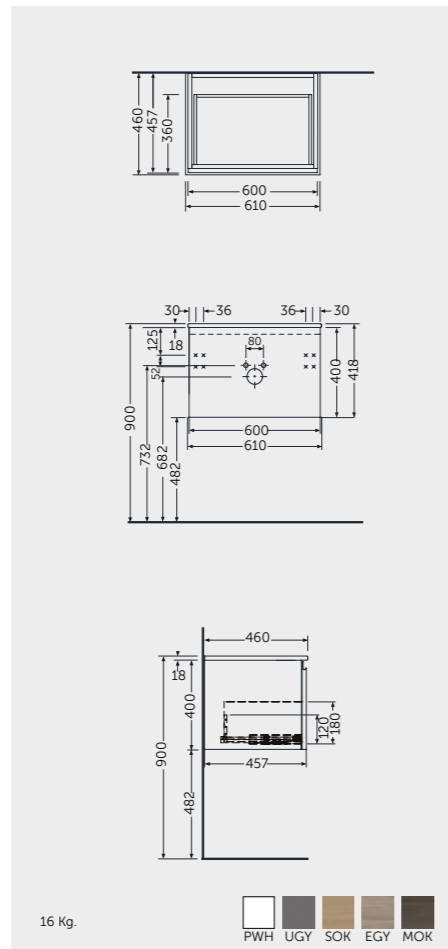
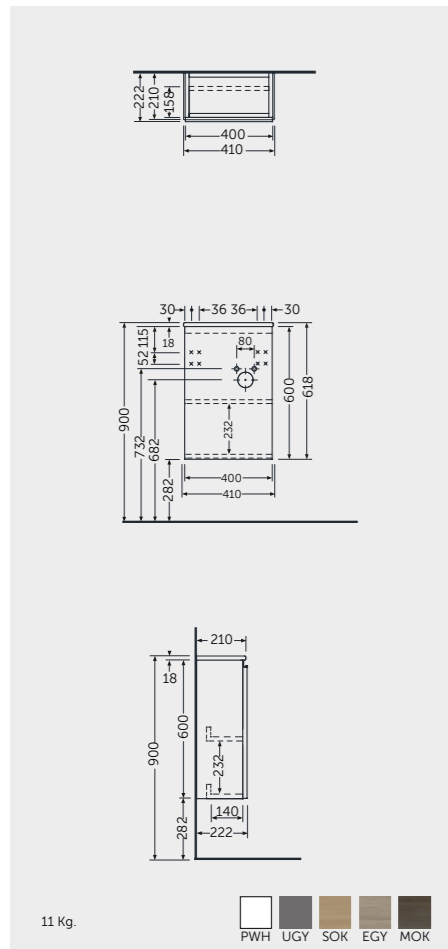

WALL HUNG VANITY UNITS

Mobili sospesi | Meubles suspendus | Mueble de baño suspendido | Waschtisch wandhängend | Подвесная тумба



W 100 x D 46 x H 40CM  
UNOWH100UGY

Space saving bottle trap required BTRWBPPR022



120cm = 2x W 60CM Units  
UNOWH060UGY x2

Space saving bottle trap required BTRWBPPR022 ( x2 )



FOR VANITY  
PP WHITE : BTRWBPPR022  
Inspectionable  
Space Saving

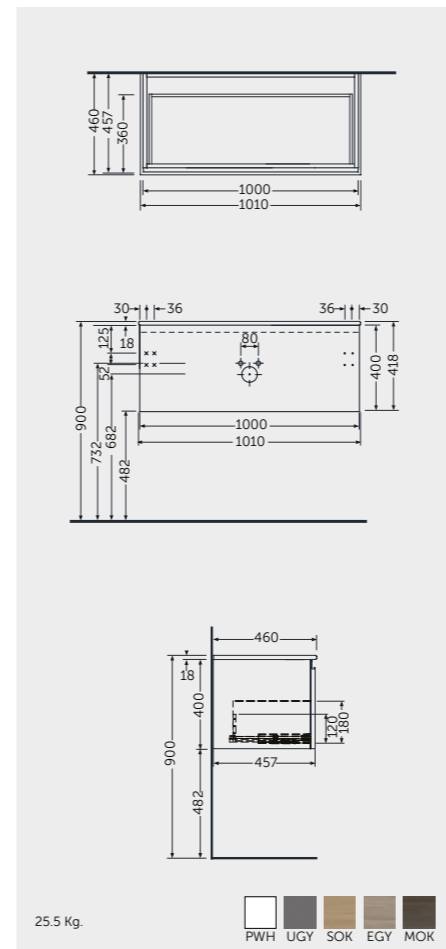

160cm = 2x W 80CM Units  
UNOWH080UGY x2

Space saving bottle trap required BTRWBPPR022 ( x2 )



200cm = 2x W 100CM Units  
UNOWH100UGY x2

Space saving bottle trap required BTRWBPPR022 ( x2 )



# OPEN STORAGE AND TALL CABINET UNITS

## OPEN STORAGE UNIT

Vani a vista | Unités de stockage ouvertes | Unidades de almacenamiento abierto | Offene Lagerungseinheiten | Открытые ячейки



60 CM  
JOYOS040MGY

## TALL CABINET UNIT

Colonna sospesa | Colonne suspendue | Columna suspendida | Hochschrank | Высокий подвесной шкаф



W 30 x D 23 x H 120CM  
JOYTS120UGY

Measurements | Misure | Dimensions | Medidas | Abmessungen | Размеры

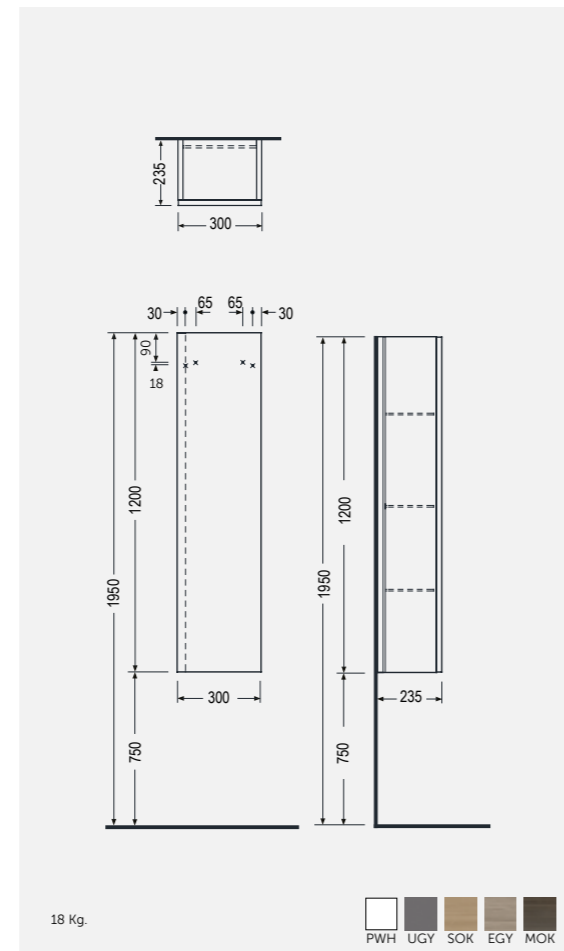
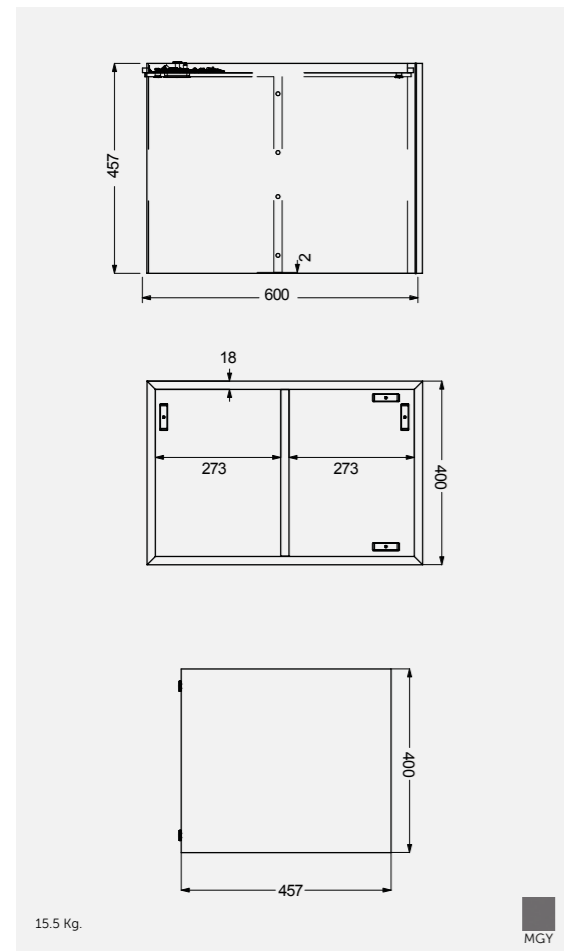



## WITH RAK-JOY OR RAK-PRECIOUS DROP-IN WASHBASINS

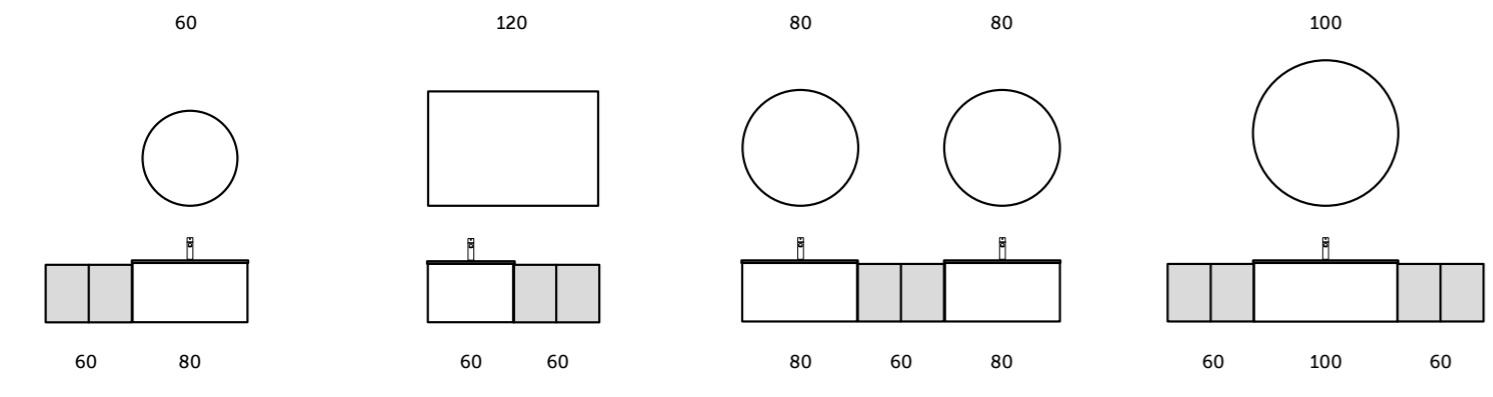

LEFT

RIGHT

MIDDLE

BOTH ENDS

## WITH RAK-DES WASHBASINS

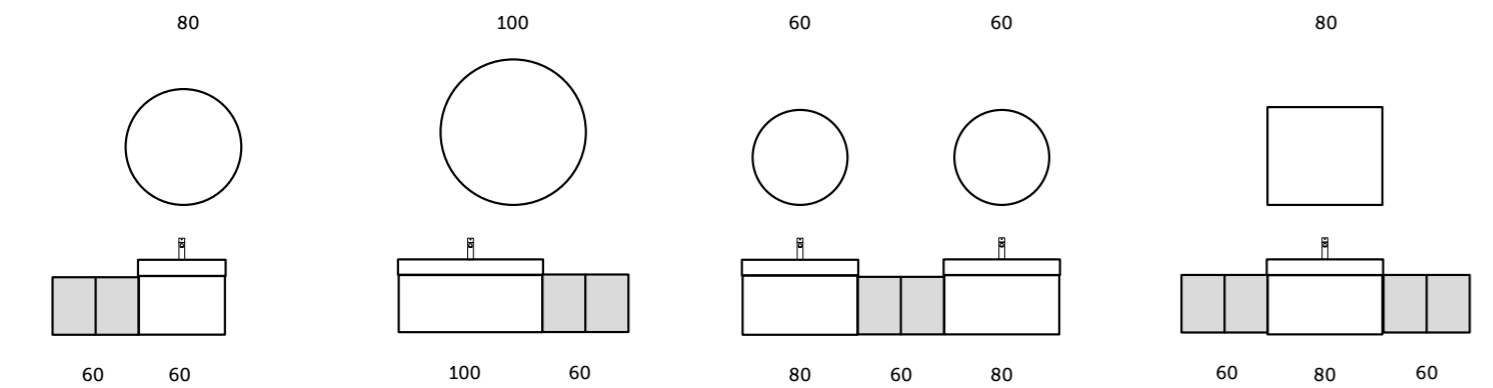

LEFT

RIGHT

MIDDLE

BOTH ENDS

## WITH RAK-PRECIOUS SURFACE AND COUNTERTOP WASHBASINS

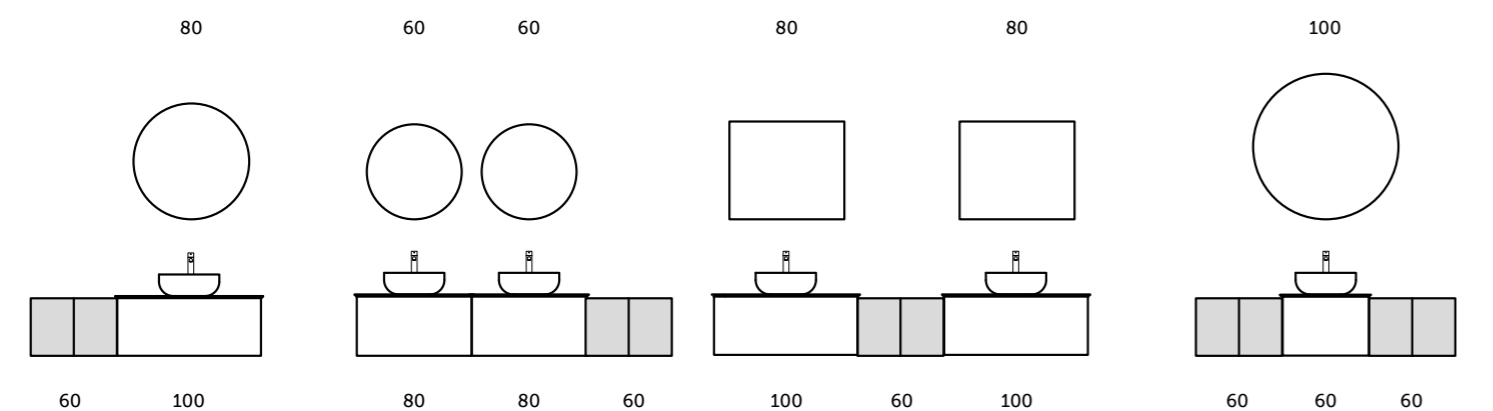

LEFT

RIGHT

MIDDLE

BOTH ENDS

## RAK-JOY + RAK-PRECIOUS + OPEN STORAGE UNIT

Elevate your bathroom's style and functionality with the combination of RAK Precious drop in washbasin or countertop, RAK-Joy Vanity Unit and a modular Open Storage system. Designed to be mixed and matched according to your style, this combination offers the best space-saving solution, essential in keeping your bathroom organized.



Stile e funzionalità si fondono alla perfezione nel tuo bagno, grazie alla elegante composizione di RAK Precious lavabo da incasso o piano di lavoro, mobile bagno RAK-Joy e un sistema modulare Open Storage. Progettata per essere mixata e abbinata in base al tuo stile, questa combinazione offre la migliore soluzione salvaspazio, essenziale per mantenere organizzato il tuo bagno.



Améliorez le style et la fonctionnalité de votre salle de bains par la combinaison d'un bouchon d'écoulement pour lavabo ou plan de RAK Precious, un porte-lavabo de RAK-Joy et un système modulaire de stockage ouvert. Projetée pour être composée selon votre style, cette combinaison offre la meilleure solution peu encombrante, essentielle pour maintenir votre salle de bains bien organisée.



Eleva el estilo y la funcionalidad de tu cuarto de baño con la combinación de RAK Precious drop en el lavabo o en la encimera, la unidad de tocador RAK-Joy y un sistema modular de almacenamiento abierto. Diseñado para mezclarse y combinarse de acuerdo a tu estilo, esta combinación ofrece la mejor solución para ahorrar espacio, esencial para mantener tu baño organizado.



Werten Sie den Stil und die Funktionalität Ihres Badezimmers auf, mit der Kombination aus der Ablaufgarnitur für Waschbecken oder Arbeitsplatte RAK Precious, dem Unterschrank RAK-Joy und dem offenen Modularlagerungssystem. Entworfen um passend zu Ihrem Stil zusammengestellt zu werden, bietet diese Kombination die beste platzsparende Lösung, die wesentlich ist, um Ihr Badezimmer ordentlich zu halten.



Улучшите стиль и функциональность вашей ванной комнаты с помощью комбинации Rak Precious для накладных и встраиваемых раковин, Rak-Joy с наиболее понравившейся тумбой и модульной открытой системой хранения. Комбинация разработана, чтобы дать Вам возможность подбирать и составлять в соответствии с вашим стилем, эта комбинация предлагает лучшее решение для экономии места и пространства, необходимое для поддержания вашей ванной комнаты в порядке.



RAK-Joy washbasins



RAK-Des washbasins



RAK-Precious washbasins



Counter top washbasins



RAK-Precious counter top surfaces

DROP IN WASH BASINS | Lavabi da incasso | Plan vasque | Drop-in Waschbecken | Встраиваемая раковина



41 x 22CM  
JOYWB4106AWHA



61 x 46CM  
JOYDI06101WH



81 x 46CM  
JOYDI08101WH

Measurements | Misure | Dimensions | Medidas | Abmessungen | Размеры

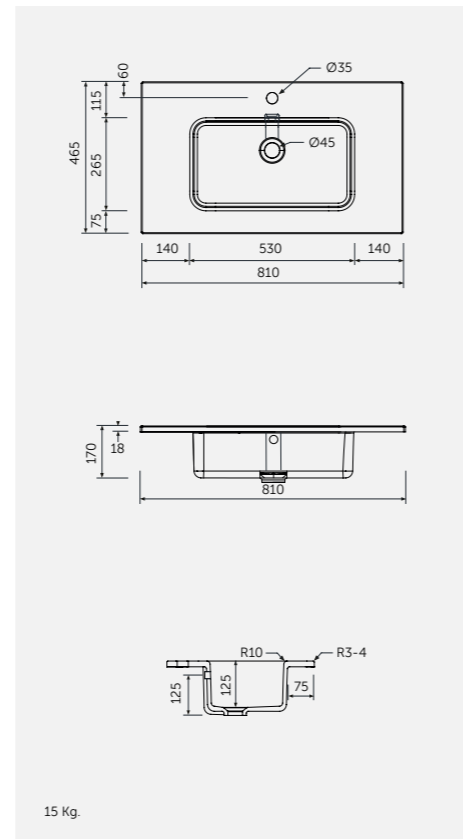
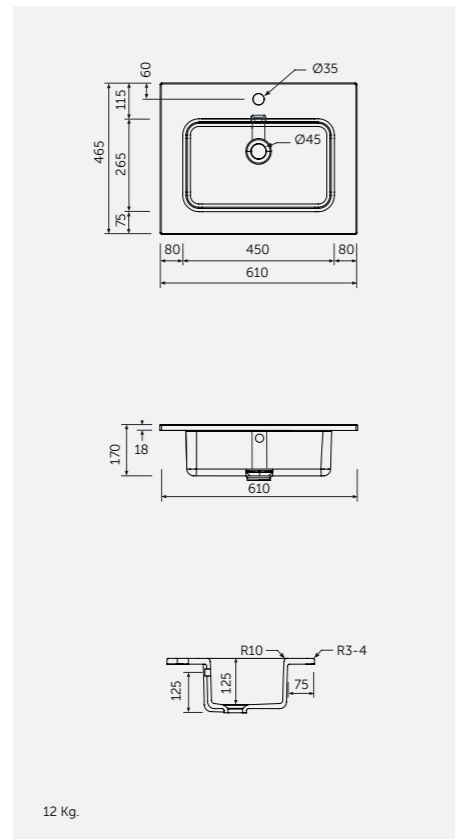
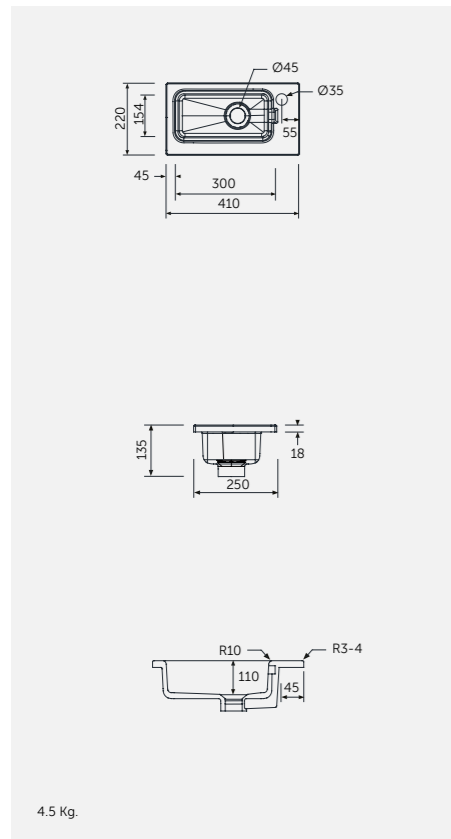

DROP IN WASH BASINS | Lavabi da incasso | Plan vasque | Drop-in Waschbecken | Встраиваемая раковина



101 x 46CM  
JOYDI10101WH



121 x 46CM  
JOYDI12102WH



FOR VANITY  
PP WHITE : BTRWBPPR022

Inspectionable  
Space Saving

Measurements | Misure | Dimensions | Medidas | Abmessungen | Размеры

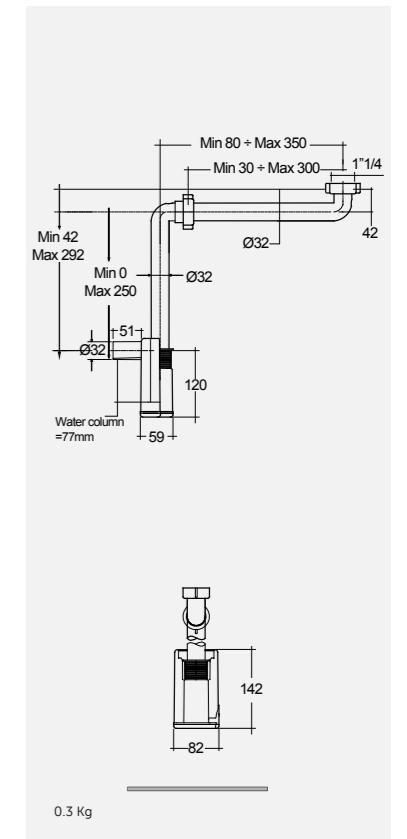
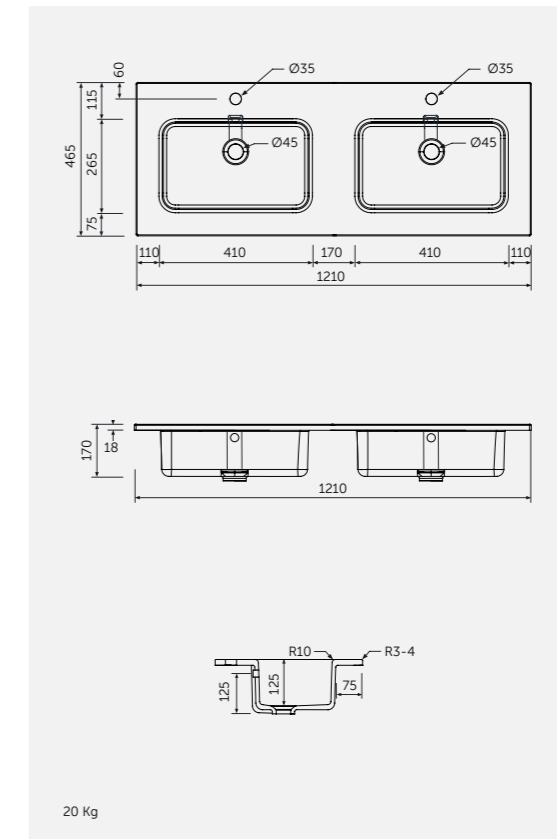
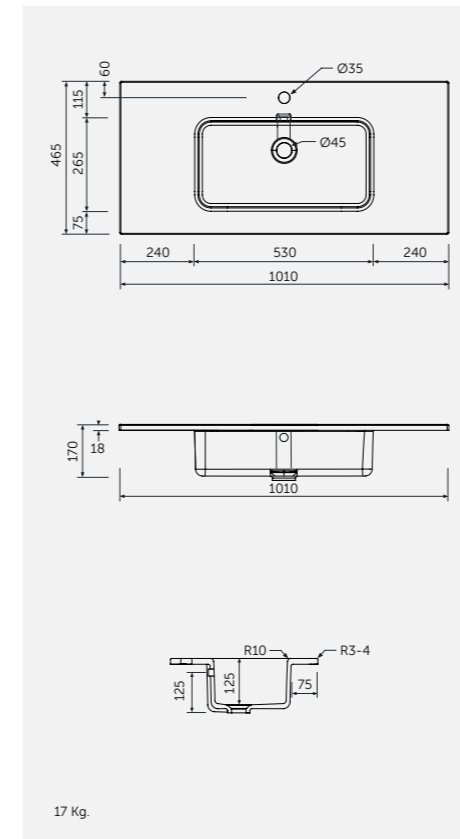

Note | Nota | Remarque | Notas | Hinweis | Примечание

All dimensions in mm tolerance  $\pm 5\%$  for below 200mm and  $\pm 3\%$  for above 200mm | Tutte le dimensioni hanno una tolleranza di  $\pm 5\%$  mm al di sotto dei 200mm e di  $\pm 3\%$  mm al di sopra dei 200mm | Toutes les dimensions en mm tolérance  $\pm 5\%$  pour moins de 200mm et  $\pm 3\%$  pour plus de 200mm | Todas las medidas en mm con tolerancia de 5% para menos de 200mm y 3% para más de 200mm | Alle Abmessungen in mm, Toleranz  $\pm 5\%$  für unter 200mm, und  $\pm 3\%$  für über 200mm | Все размеры указаны в мм, погрешность  $\pm 5\%$  ниже 200 мм и  $\pm 3\%$  выше 200 мм



DROP IN WASH BASINS | Lavabi da incasso | Plan vasque | Drop-in Waschbecken | Встраиваемая раковина



61 x 46 CM  
DESWB06101AWHA



81 x 46 CM  
DESWB08101AWHA



101 x 46 CM  
DESWB10101AWHA

Measurements | Misure | Dimensions | Medidas | Abmessungen | Размеры

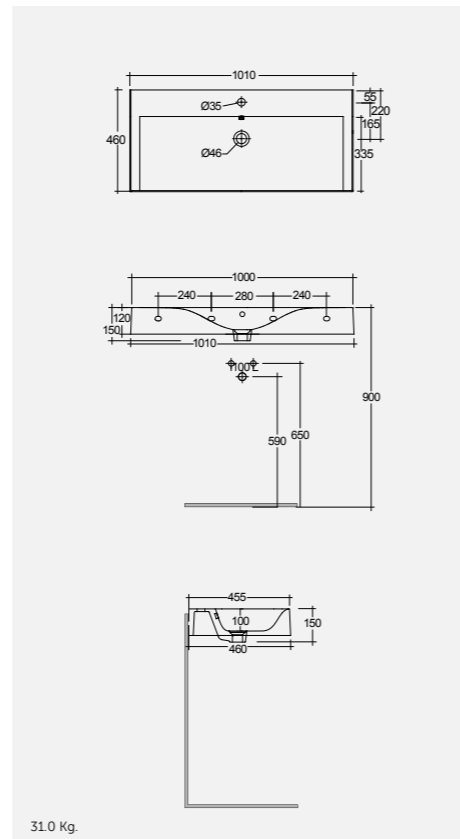
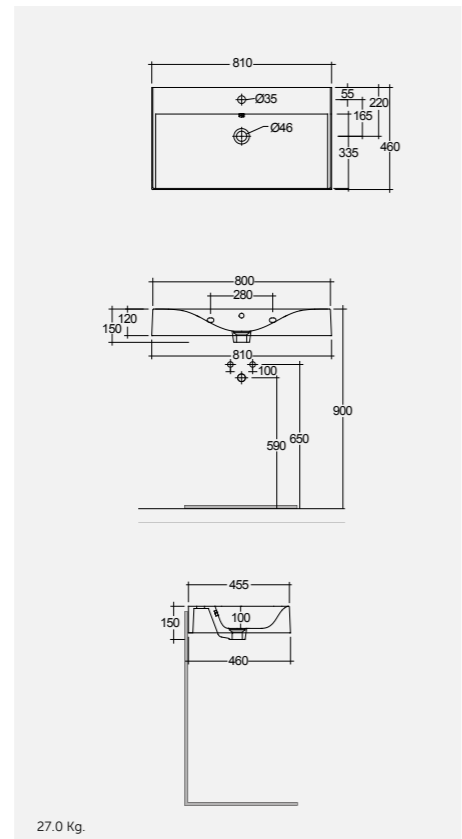
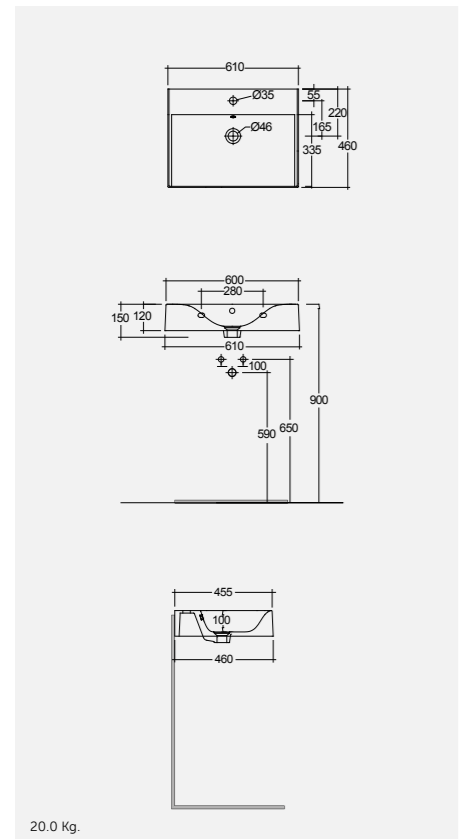

Note | Nota | Remarque | Notas | Hinweis | Примечание

All dimensions in mm tolerance  $\pm 5\%$  for below 200mm and  $\pm 3\%$  for above 200mm | Tutte le dimensioni hanno una tolleranza di  $\pm 5\%$  mm al di sotto dei 200mm e di  $\pm 3\%$  mm al di sopra dei 200mm | Toutes les dimensions en mm tolérance  $\pm 5\%$  pour moins de 200mm et  $\pm 3\%$  pour plus de 200mm | Todas las medidas en mm con tolerancia de 5% para menos de 200mm y 3% para más de 200mm | Alle Abmessungen in mm, Toleranz  $\pm 5\%$  für unter 200mm, und  $\pm 3\%$  für über 200mm | Все размеры указаны в мм, погрешность  $\pm 5\%$  ниже 200 мм и  $\pm 3\%$  выше 200 мм

DROP IN WASH BASINS | Lavabi da incasso | Plan vasque | Drop-in Waschbecken | Встраиваемая раковина



121 x 46 CM  
DESWB12101AWHA



FREE-FLOW  
CHROME : DUO002444

CLICK-CLACK  
CHROME : DUO000444



FOR VANITY  
PP WHITE : BTRWBPPR022

Inspectionable  
Space Saving

Measurements | Misure | Dimensions | Medidas | Abmessungen | Размеры

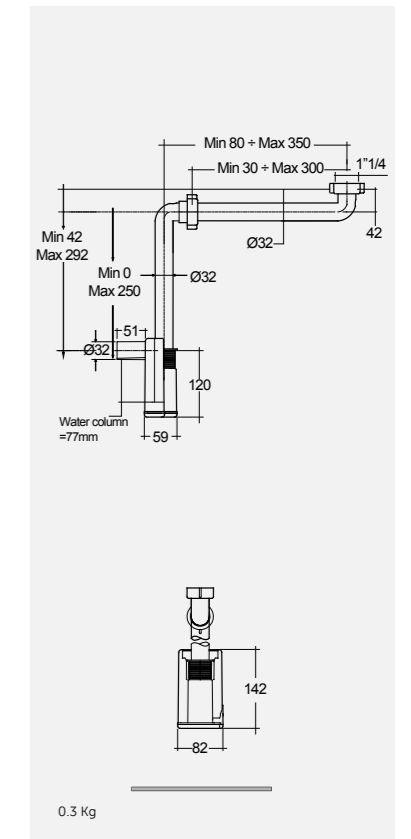
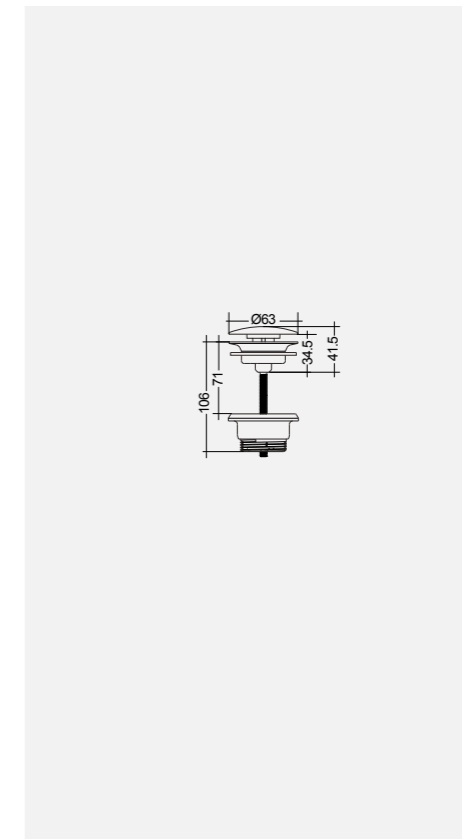
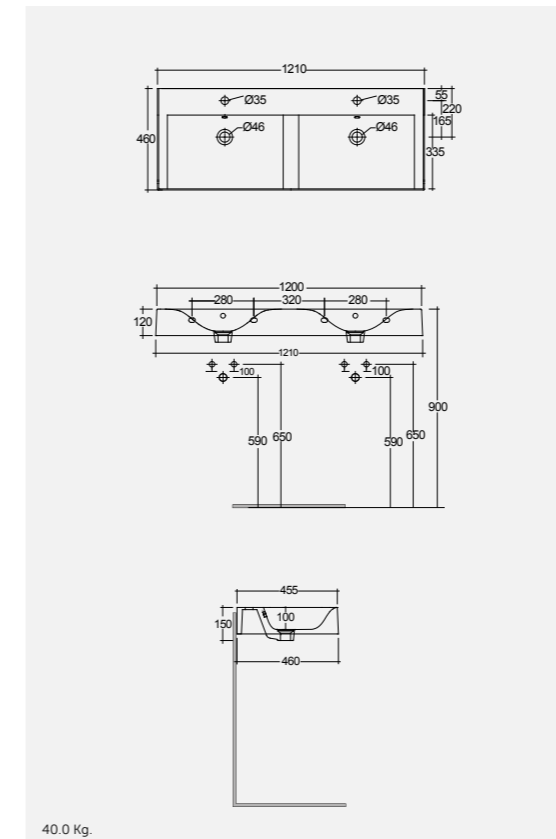

DROP IN WASH BASINS | Lavabi da incasso | Plan vasque | Drop-in Waschbecken | Встраиваемая раковина



61 x 46 CM  
DESWB06100AWHA



81 x 46 CM  
DESWB08100AWHA



101 x 46 CM  
DESWB10100AWHA

Measurements | Misure | Dimensions | Medidas | Abmessungen | Размеры

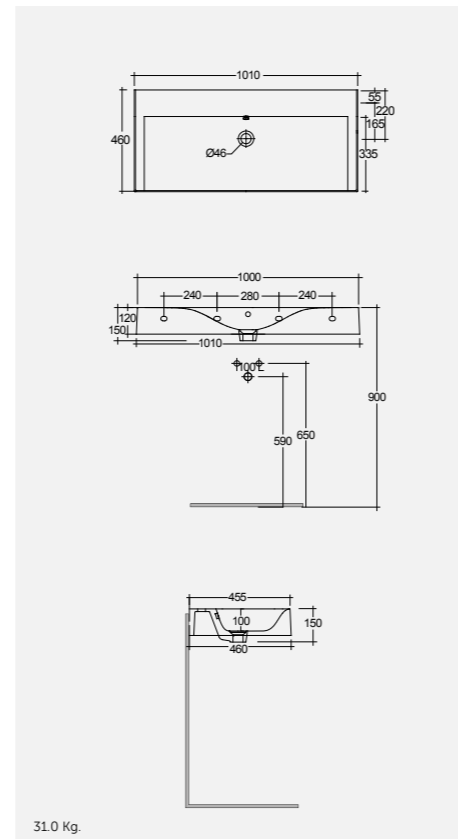
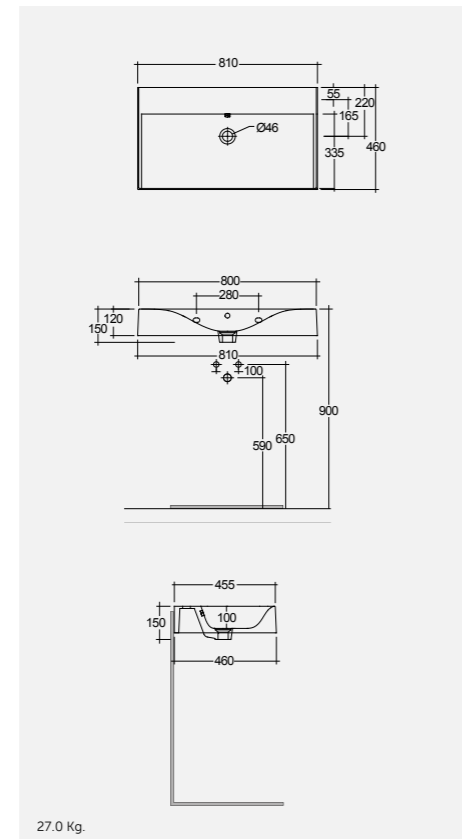
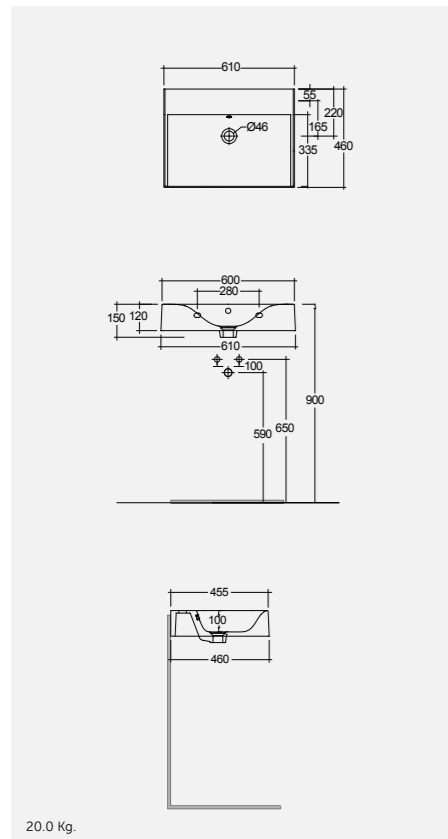

Note | Nota | Remarque | Notas | Hinweis | Примечание

All dimensions in mm tolerance  $\pm 5\%$  for below 200mm and  $\pm 3\%$  for above 200mm | Tutte le dimensioni hanno una tolleranza di  $\pm 5\%$  mm al di sotto dei 200mm e di  $\pm 3\%$  mm al di sopra dei 200mm | Toutes les dimensions en mm tolérance  $\pm 5\%$  pour moins de 200mm et  $\pm 3\%$  pour plus de 200mm | Todas las medidas en mm con tolerancia de 5% para menos de 200mm y 3% para más de 200mm | Alle Abmessungen in mm, Toleranz  $\pm 5\%$  für unter 200mm, und  $\pm 3\%$  für über 200mm | Все размеры указаны в мм, погрешность  $\pm 5\%$  ниже 200 мм и  $\pm 3\%$  выше 200 мм

DROP IN WASH BASINS | Lavabi da incasso | Plan vasque | Drop-in Waschbecken | Встраиваемая раковина



121 x 46 CM  
DESWB12100AWHA



FREE-FLOW  
CHROME : DUO002444

CLICK-CLACK  
CHROME : DUO000444



FOR VANITY  
PP WHITE : BTRWBPPR022

Inspectionable

Space Saving

Measurements | Misure | Dimensions | Medidas | Abmessungen | Размеры

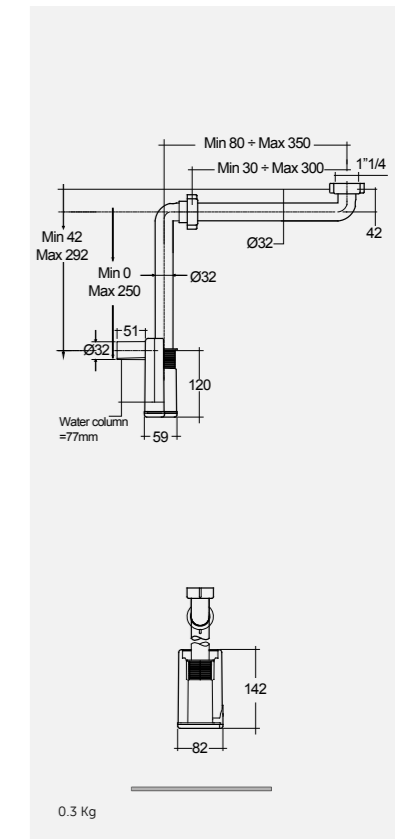
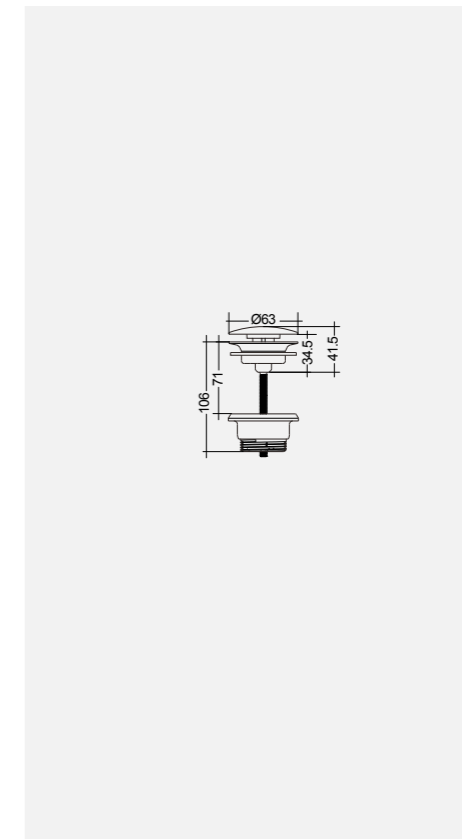
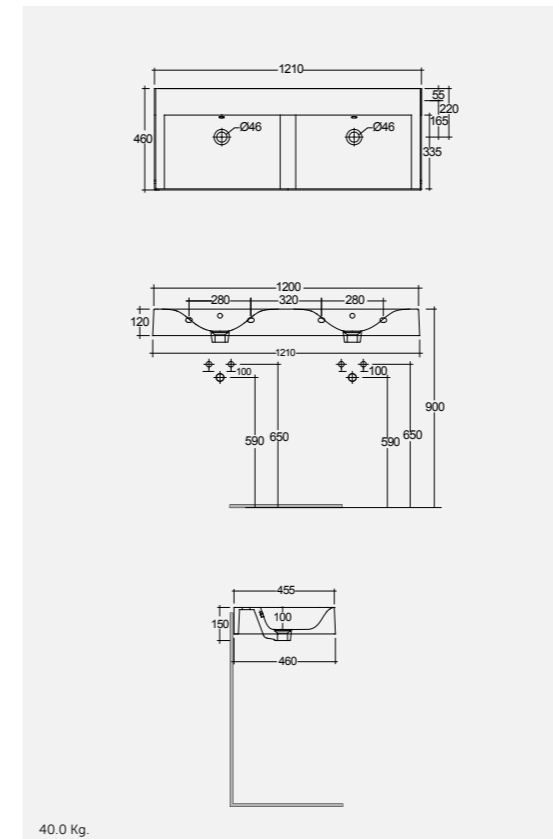



MIRRORS | Specchi | Miroirs | Espejos | Spiegel | Зеркала

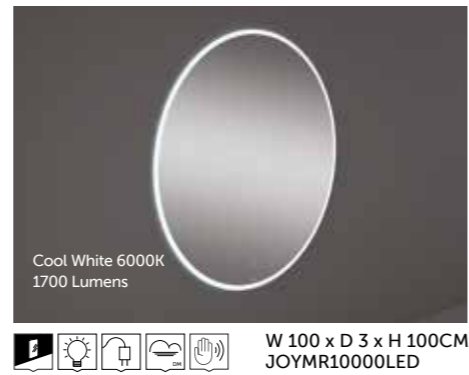
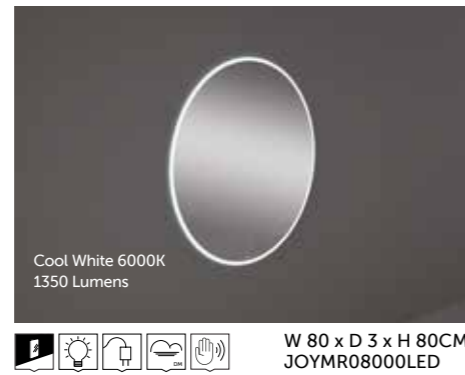
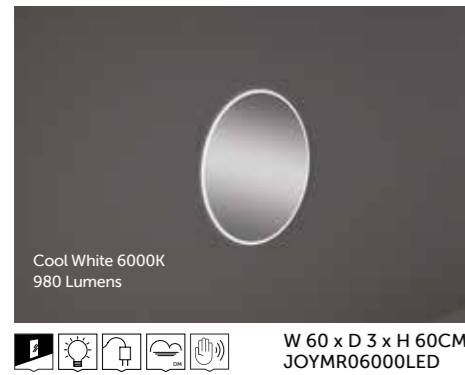

Measurements | Misure | Dimensions | Medidas | Abmessungen | Размеры

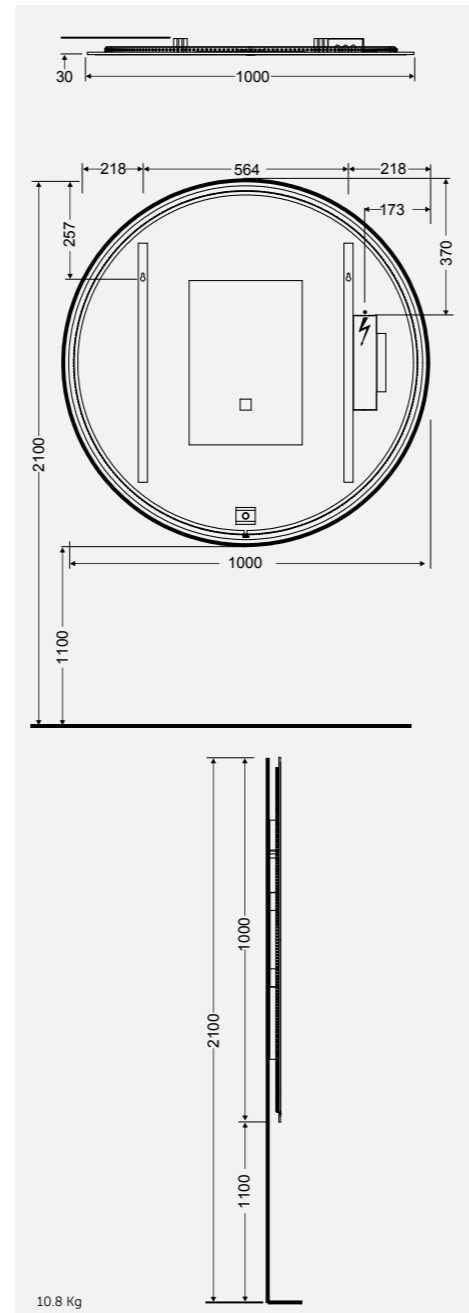
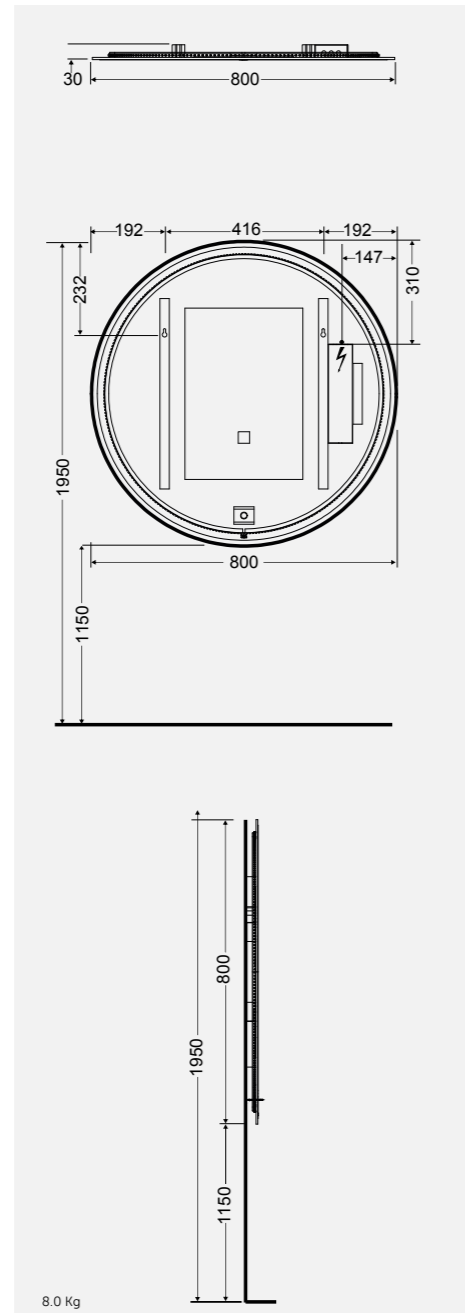
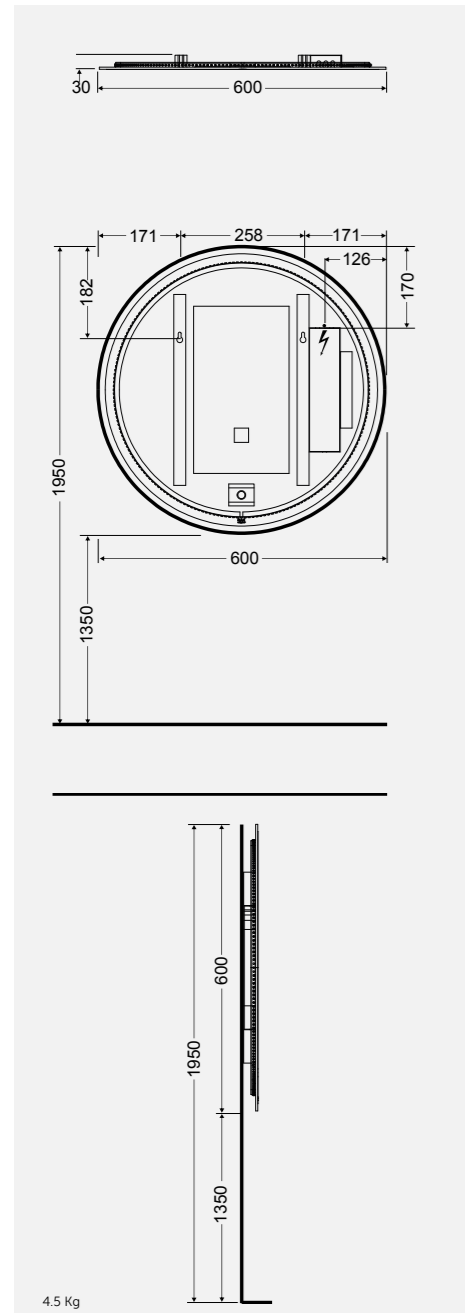

MIRROR CABINETS | Specchi contenitivi | Miroirs armoires toilette | Espejos Contenedores | Spiegel Schränke | Зеркала шкафчики



W 40 x D 18 x H 68CM  
JOYMC04001



W 60 x D 18 x H 68CM  
JOYMC06002



W 80 x D 18 x H 68CM  
JOYMC08002

MIRROR CABINETS | Specchi contenitivi | Miroirs armoires toilette | Espejos Contenedores | Spiegel Schränke | Зеркала шкафчики



W 100 x D 18 x H 68CM  
JOYMC10003



120CM = 2x W 60 x D 18 x H 68CM  
Cabinets  
JOYMC06002 x2



BRASS: JOYTB6000CR  
ABS: JOYTB6000CR1  
Cool White 6000K  
450 Lumens

Measurements | Misure | Dimensions | Medidas | Abmessungen | Размеры

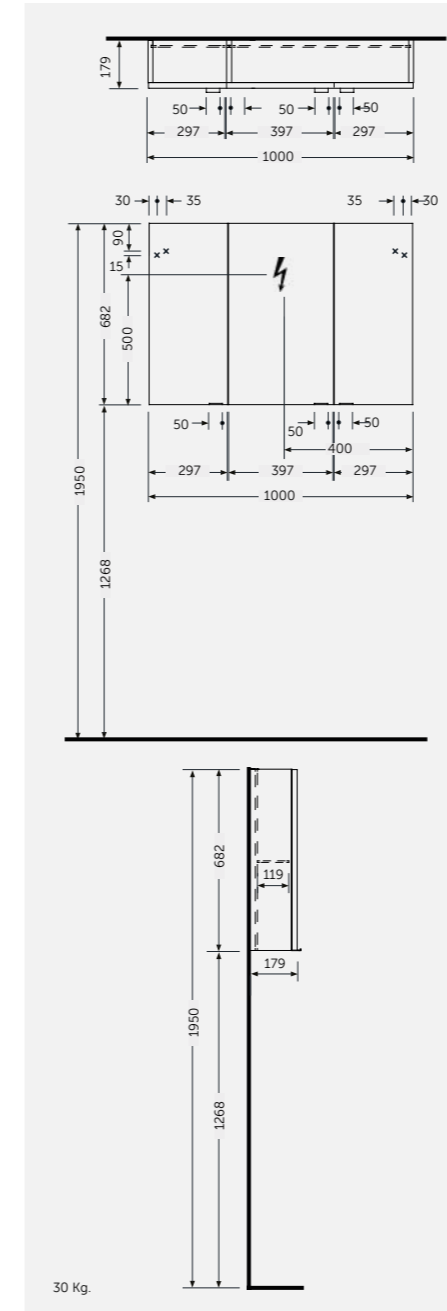
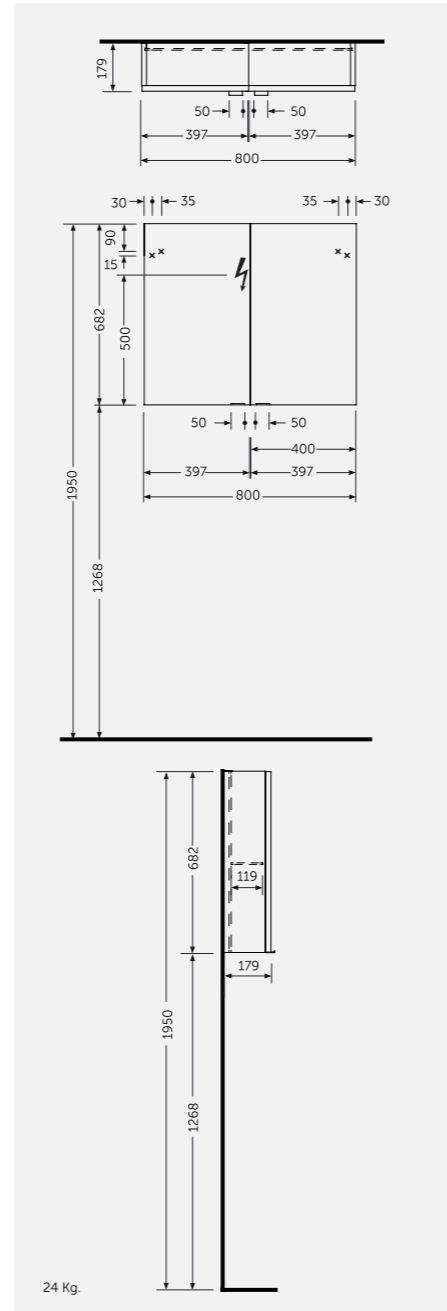
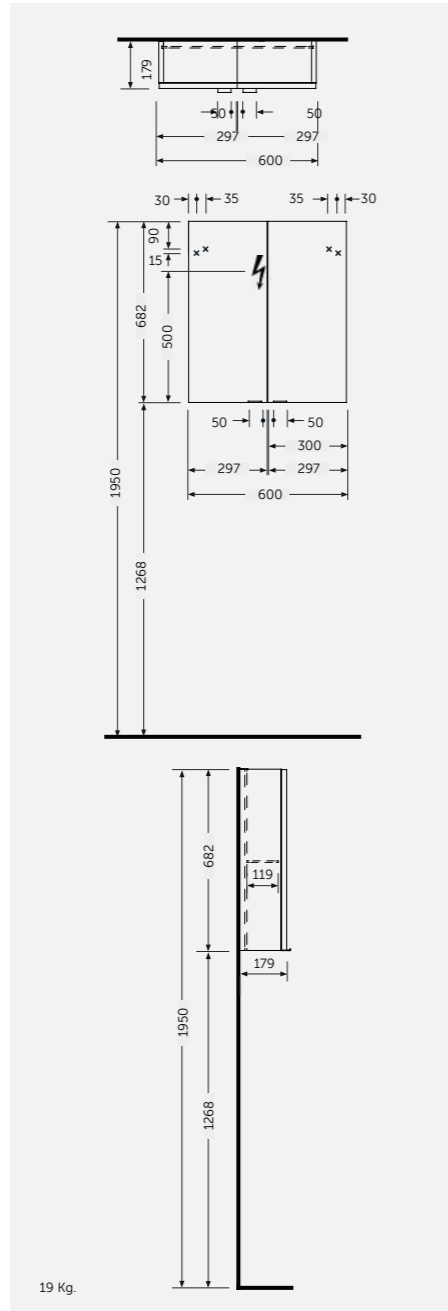
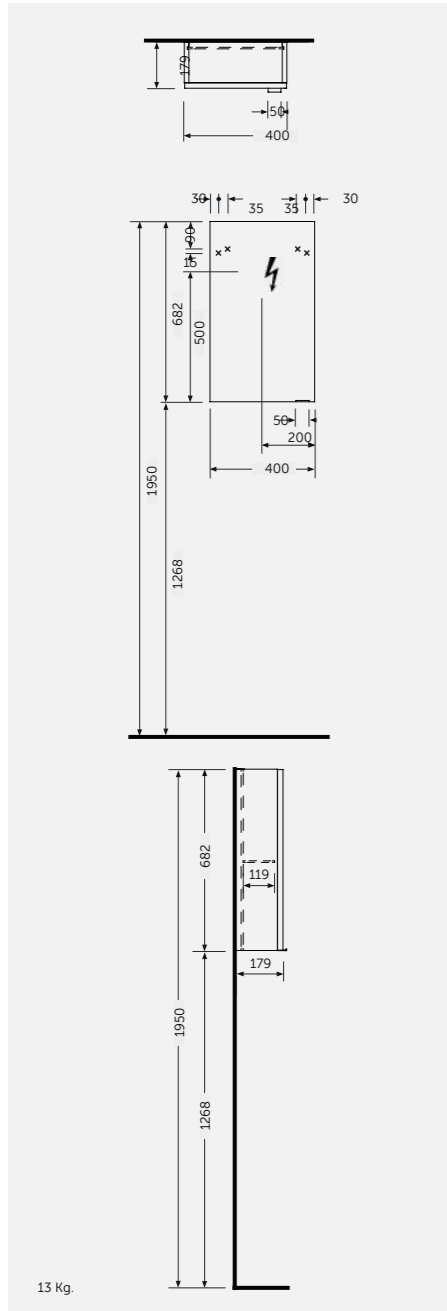

160CM = 2x W 80 x D 18 x H 68CM  
Cabinets  
JOYMC08002 x2



JOYUSBRCCR  
Neutral White 4000K  
150 Lumens



200CM = 2x W 100 x D 18 x H 68CM  
Cabinets  
JOYMC10003 x2



MIRRORS | Specchi | Miroirs | Espejos | Spiegel | Зеркала



W 40 x D 3 x H 68CM  
JOYMR04068STD



W 60 x D 3 x H 68CM  
JOYMR06068STD



W 80 x D 3 x H 68CM  
JOYMR08068STD

Measurements | Misure | Dimensions | Medidas | Abmessungen | Размеры

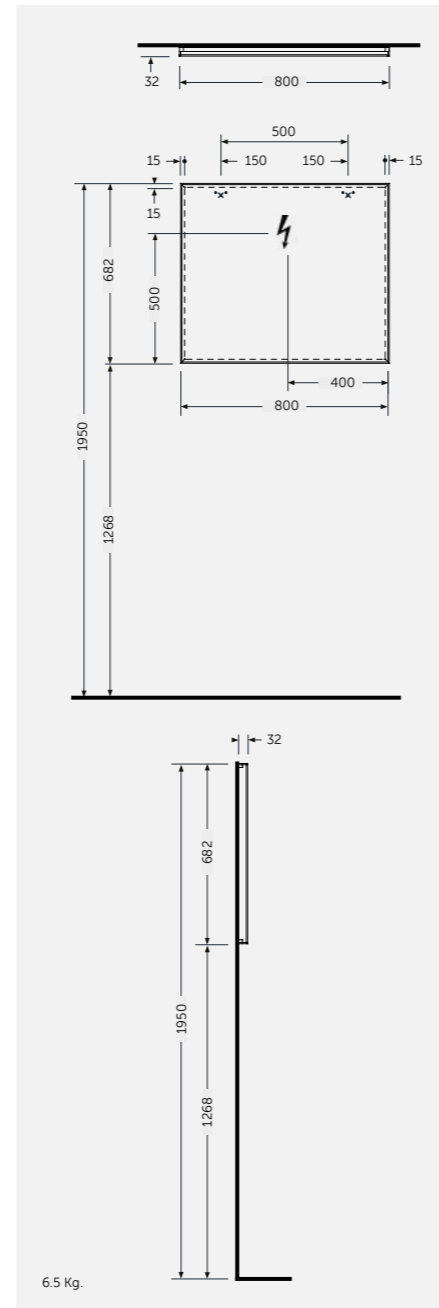
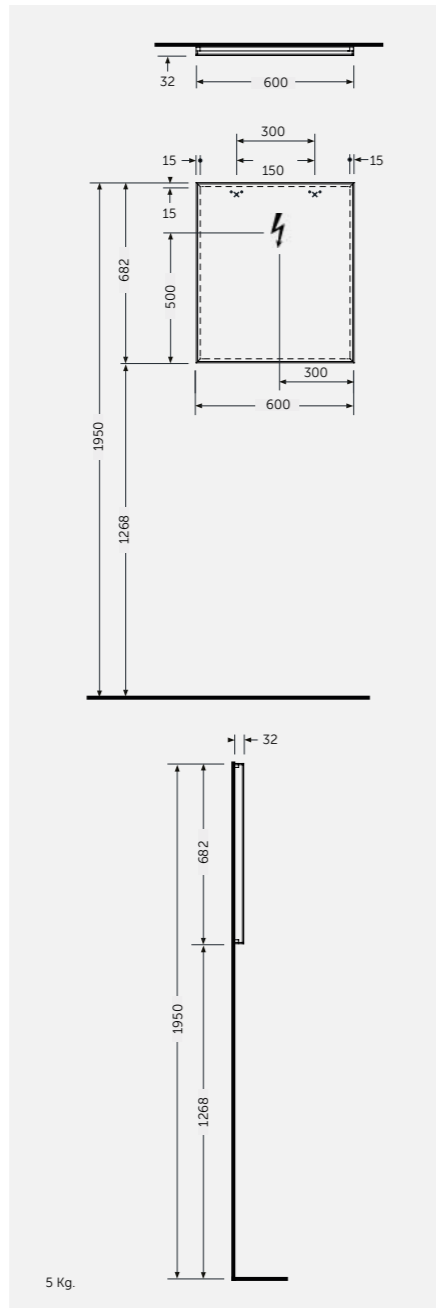
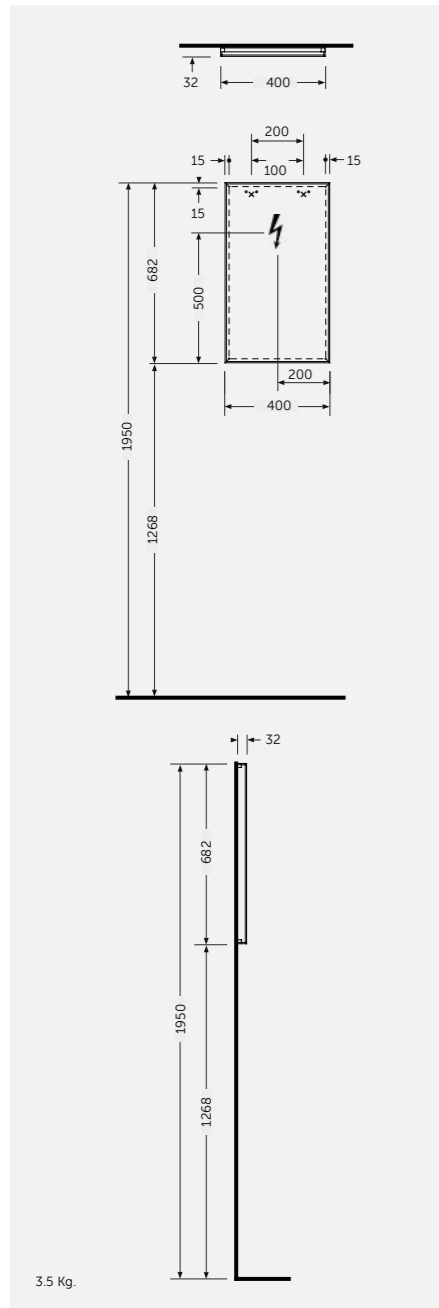

MIRRORS | Specchi | Miroirs | Espejos | Spiegel | Зеркала



W 100 x D 3 x H 68CM  
JOYMR10068STD

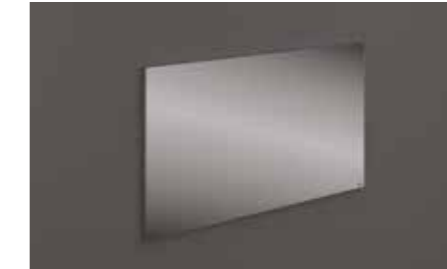

W 120 x D 3 x H 68CM  
JOYMR12068STD

Measurements | Misure | Dimensions | Medidas | Abmessungen | Размеры

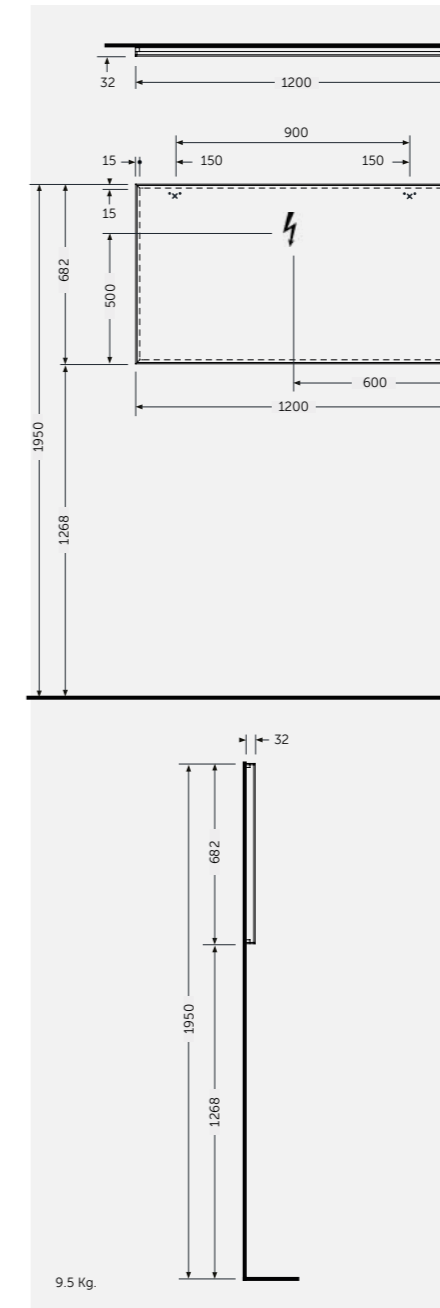
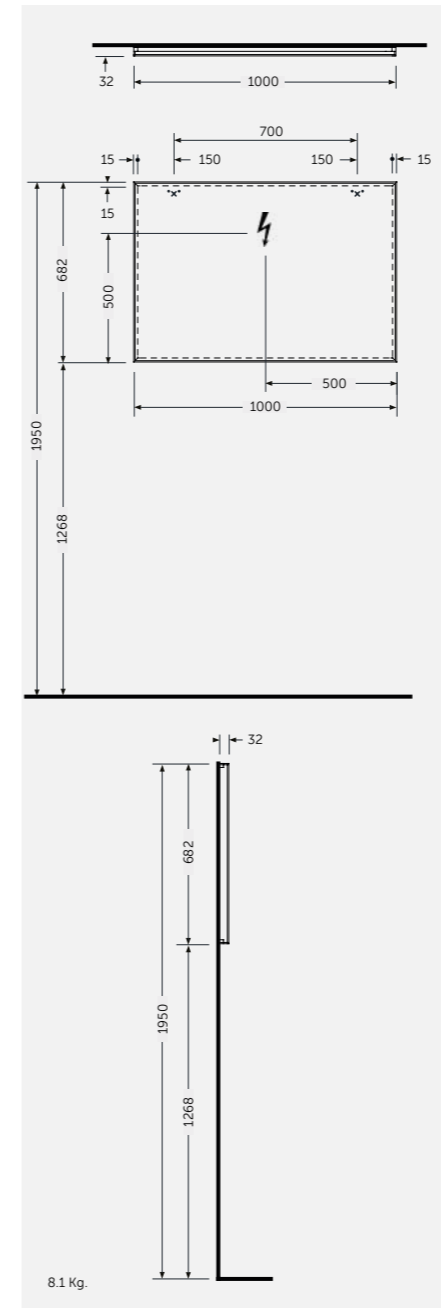

BRASS: JOYTB6000CR  
ABS: JOYTB6000CR1  
Cool White 6000K  
450 Lumens



# MIRRORS

MIRRORS | Specchi | Miroirs | Espejos | Spiegel | Зеркала



W 40 x D 3 x H 68CM  
JOYMR04068LED

Cool White 6000K  
400 Lumens

Measurements | Misure | Dimensions | Medidas | Abmessungen | Размеры

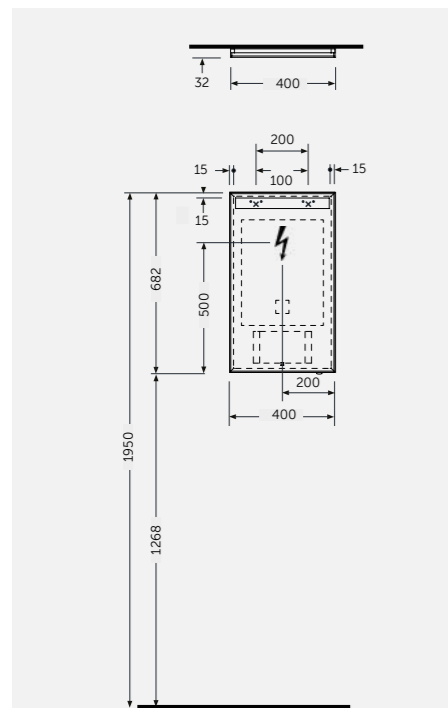

4.3 Kg.



W 60 x D 3 x H 68CM  
JOYMR06068LED

Cool White 6000K  
400 Lumens

Measurements | Misure | Dimensions | Medidas | Abmessungen | Размеры

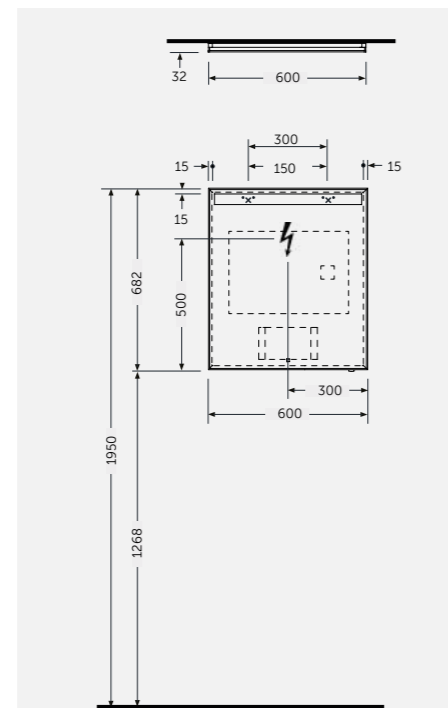

5.7 Kg.



W 80 x D 3 x H 68CM  
JOYMR08068LED

Cool White 6000K  
500 Lumens

Measurements | Misure | Dimensions | Medidas | Abmessungen | Размеры

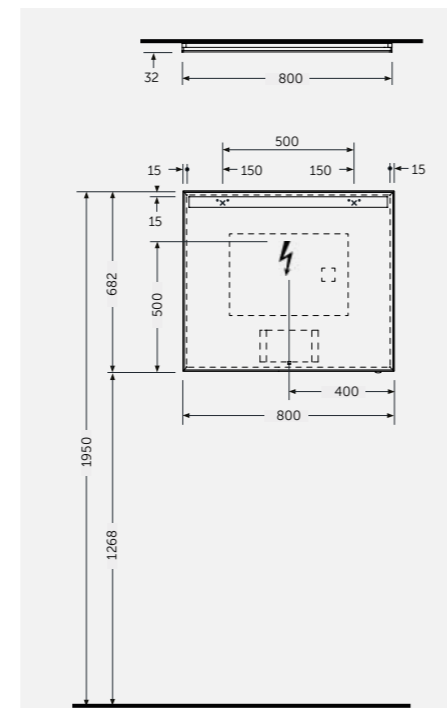

7.6 Kg.

MIRRORS | Specchi | Miroirs | Espejos | Spiegel | Зеркала



W 100 x D 3 x H 68CM  
JOYMR10068LED

Cool White 6000K  
700 Lumens

Measurements | Misure | Dimensions | Medidas | Abmessungen | Размеры

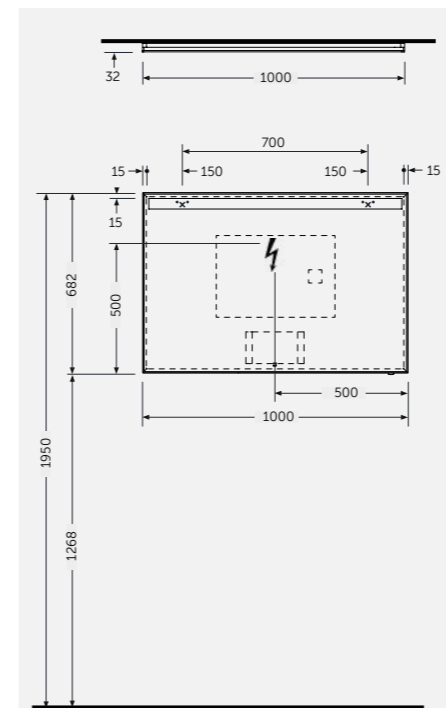

8.8 Kg.



W 120 x D 3 x H 68CM  
JOYMR12068LED

Cool White 6000K  
900 Lumens

Measurements | Misure | Dimensions | Medidas | Abmessungen | Размеры

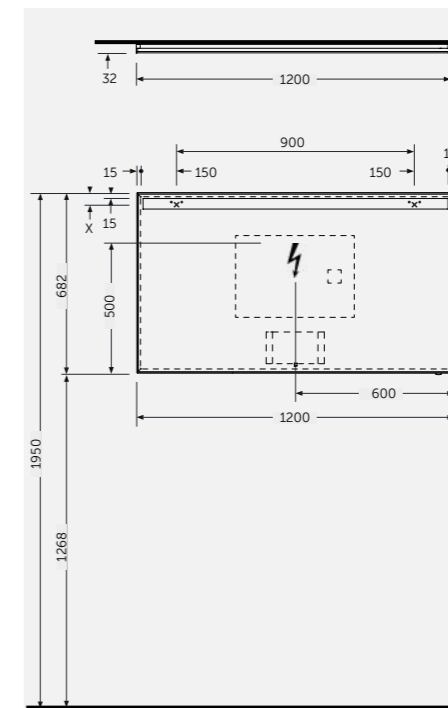

10.5 Kg.





**DRAWER  
INSERTS &  
LIGHTING**

**DRAWER INSERT ORGANISERS** | Organizzatori per cassetto | Organiseur pour tiroirs | Schubladeneinsätze Einteiler | Органайзеры для выдвижных ящиков

**TOP DRAWER INSERT**  
Organizzatori per cassetto  
Organiseur pour tiroirs  
Schubladeneinsätze Einteiler  
Вкладыш в верхний ящик



H 6 x W 11 x D 34CM  
ANTHRACITE  
JOYDIST

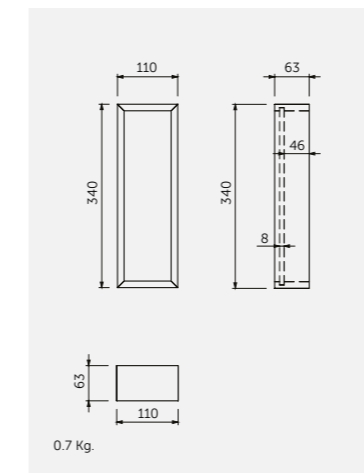

**BOTTOM DRAWER INSERT**  
Organizzatori per cassetto  
Organiseur pour tiroirs  
Schubladeneinsätze Einteiler  
Вкладыш в нижний ящик



H 20 x W 16 x D 29CM  
ANTHRACITE  
JOYDILB

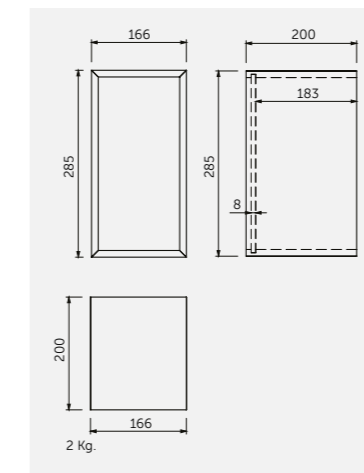

**LIGHTS** | Luci | Lumières | Beleuchtung | wandhängend | Подсветка

**TOP MOUNTED T-BAR LIGHT**  
Luce "a T" montabile in alto  
Spot en t-bar montée sur le dessus  
T-bar Aufsatzlicht  
Т-образная подсветка с верхним креплением



BRASS: JOYTB6000CR ABS: JOYTB6000CR1  
Cool White 6000K  
450 Lumens

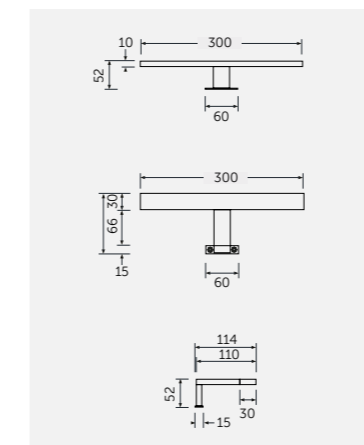

**USB RECHARGABLE LIGHT**  
Luce ricaricabile del USB  
Lumière USB rechargeable  
USB rechargeable Licht  
Заряжаемая от USB подсветка





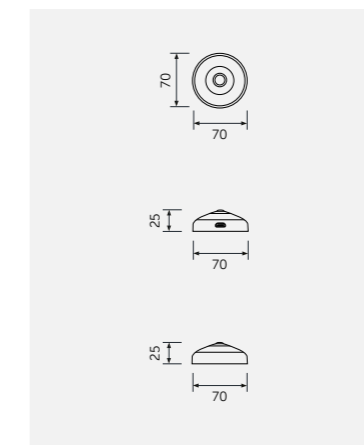





JOYUSBRCCR  
Natural White 4000K  
150 Lumens







-  W 80 x D 3 x H 80CM  
JOYMR08000LED
-  CM 36X36  
VARCT43600AWHA
-  103 CM  
PRESL10347102C
-  102
-  W 80 x D 46 x H 60CM  
UNOWH080SOK
-  SOK
-  60 CM  
JOYOS040MGY
-  MGY
-  W 60 x H 60CM  
USSAS0002504



# UNIVERSAL SHELVING SYSTEM

UNIVERSAL SHELVING SYSTEM | Sistema Di Scaffali Universale | Système De Rayonnage Universel | Universales Regalsystem | Sistema Universal De Estante | Универсальная Система Поставки



W 60CM  
USSAS0001504

Accessories included: Small Shelf & Double Tumbler



W 60 x H 60CM  
USSAS0002504

Accessories included: 2 Small Shelves & Double Tumbler



W 60 x H 180CM  
USSAS0003504

Accessories included: Small & Large Shelves, Small & Large Double Tumblers and 3 Hooks

Measurements | Misure | Dimensions | Medidas | Abmessungen | Размеры

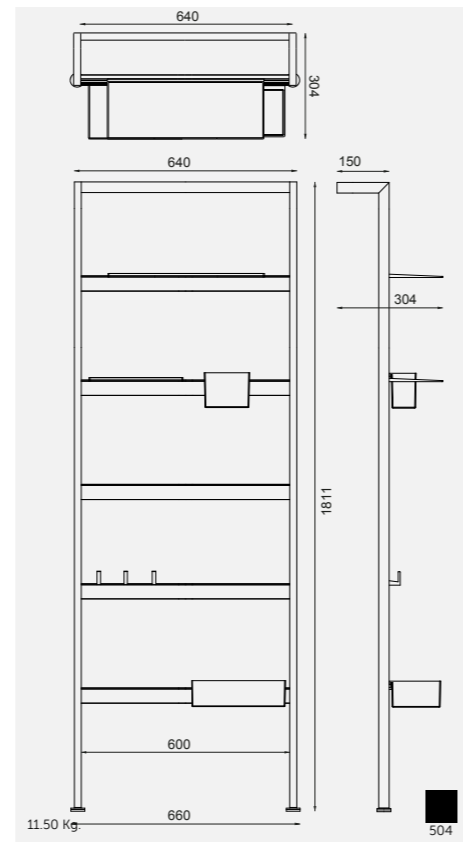
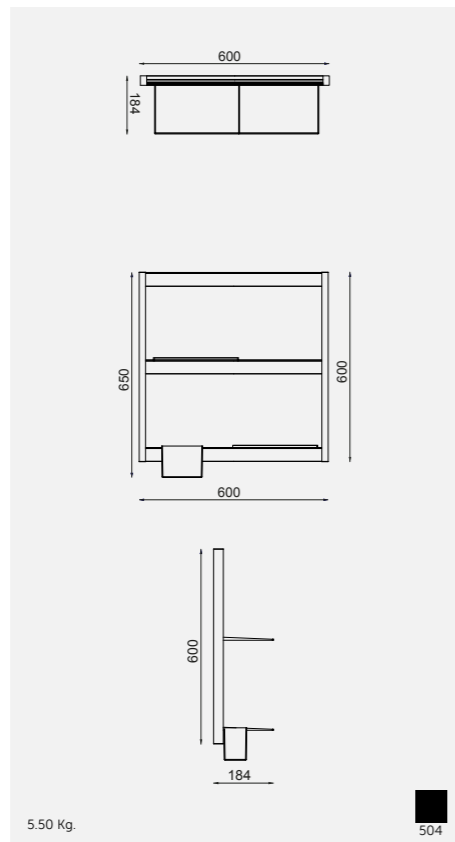
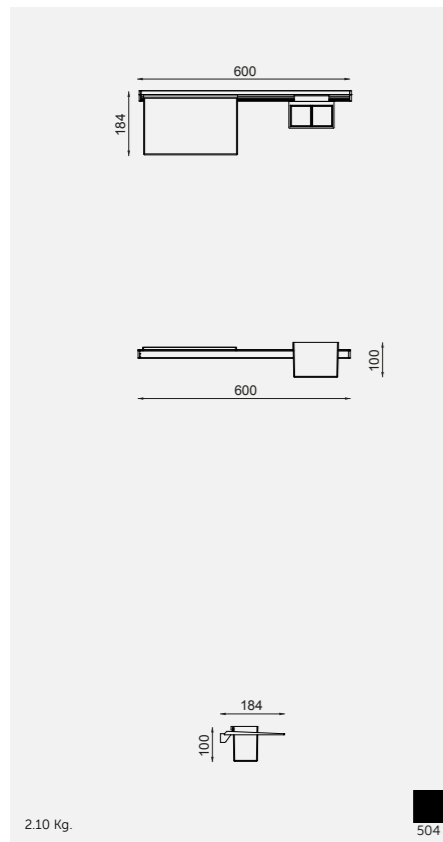

Note | Nota | Remarque | Notas | Hinweis | Примечание

All dimensions in mm tolerance  $\pm 5\%$  for below 200mm and  $\pm 3\%$  for above 200mm | Tutte le dimensioni hanno una tolleranza di  $\pm 5\%$  mm al di sotto dei 200mm e di  $\pm 3\%$  mm al di sopra dei 200mm | Toutes les dimensions en mm tolérance  $\pm 5\%$  pour moins de 200mm et  $\pm 3\%$  pour plus de 200mm | Todas las medidas en mm con tolerancia de 5% para menos de 200mm y 3% para más de 200mm | Alle Abmessungen in mm, Toleranz  $\pm 5\%$  für unter 200mm, und  $\pm 3\%$  für über 200mm | Все размеры указаны в мм, погрешность  $\pm 5\%$  ниже 200 мм и  $\pm 3\%$  выше 200 мм



# UNIVERSAL SHELVING SYSTEM

UNIVERSAL SHELVING SYSTEM | Sistema Di Scaffali Universale | Système De Rayonnage Universel | Universales Regalsystem | Sistema Universal De Estante | Универсальная Система Поставки



W 90 x D 31 x H 307CM  
USSAS0004504

Structure can be easily cut on site at any lower height; adjustable feet.

Shelves not included, order separately: USSSH9031MGY

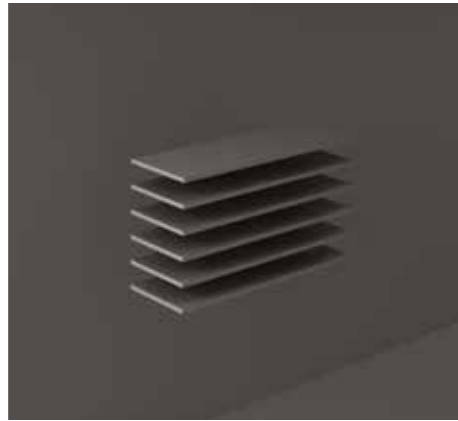

W 90 x D 31 x H 1,8CM  
USSSH9031MGY

6 PCS



W 90 x D 31 x H 307CM  
USSAS0005504

Structure can be easily cut on site at any lower height; adjustable feet.

Shelves not included, order separately: USSSH9031MGY

Measurements | Misure | Dimensions | Medidas | Abmessungen | Размеры

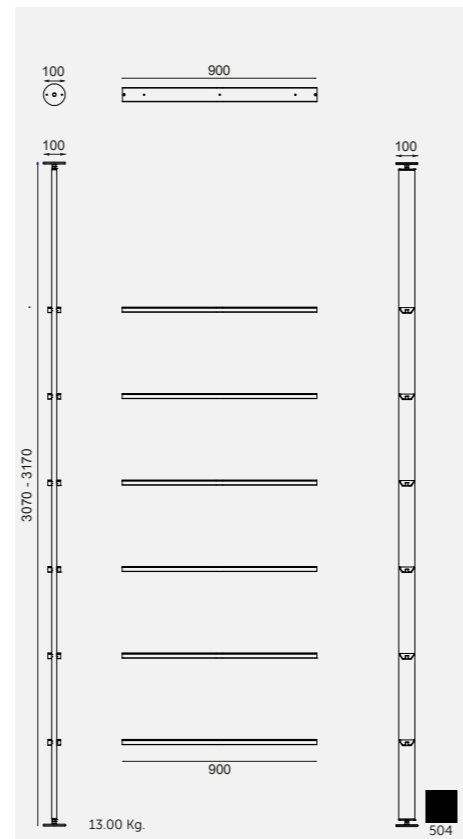
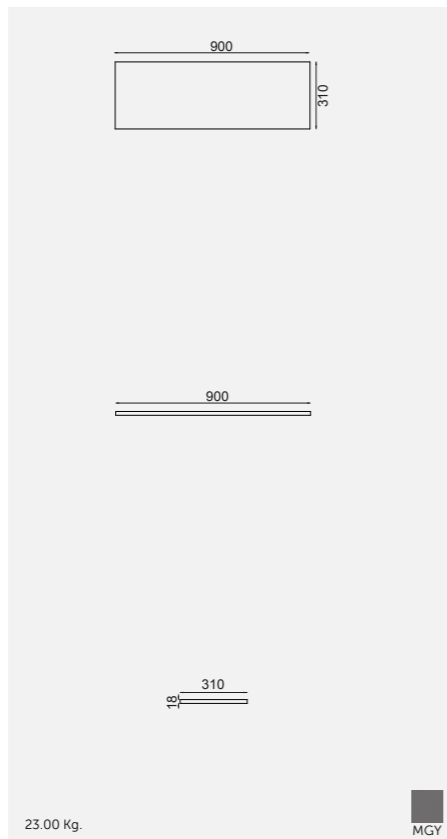
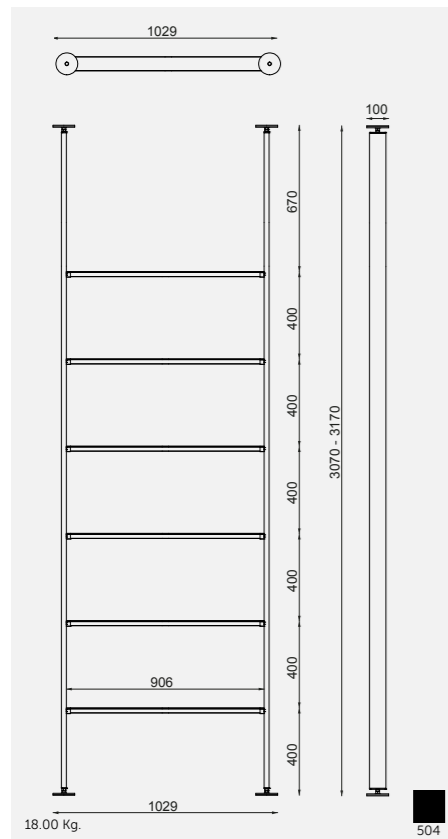

Note | Nota | Remarque | Notas | Hinweis | Примечание

All dimensions in mm tolerance  $\pm 5\%$  for below 200mm and  $\pm 3\%$  for above 200mm | Tutte le dimensioni hanno una tolleranza di  $\pm 5\%$  mm al di sotto dei 200mm e di  $\pm 3\%$  mm al di sopra dei 200mm | Toutes les dimensions en mm tolérance  $\pm 5\%$  pour moins de 200mm et  $\pm 3\%$  pour plus de 200mm | Todas las medidas en mm con tolerancia de 5% para menos de 200mm y 3% para más de 200mm | Alle Abmessungen in mm, Toleranz  $\pm 5\%$  für unter 200mm, und  $\pm 3\%$  für über 200mm | Все размеры указаны в мм, погрешность  $\pm 5\%$  ниже 200 мм и  $\pm 3\%$  выше 200 мм

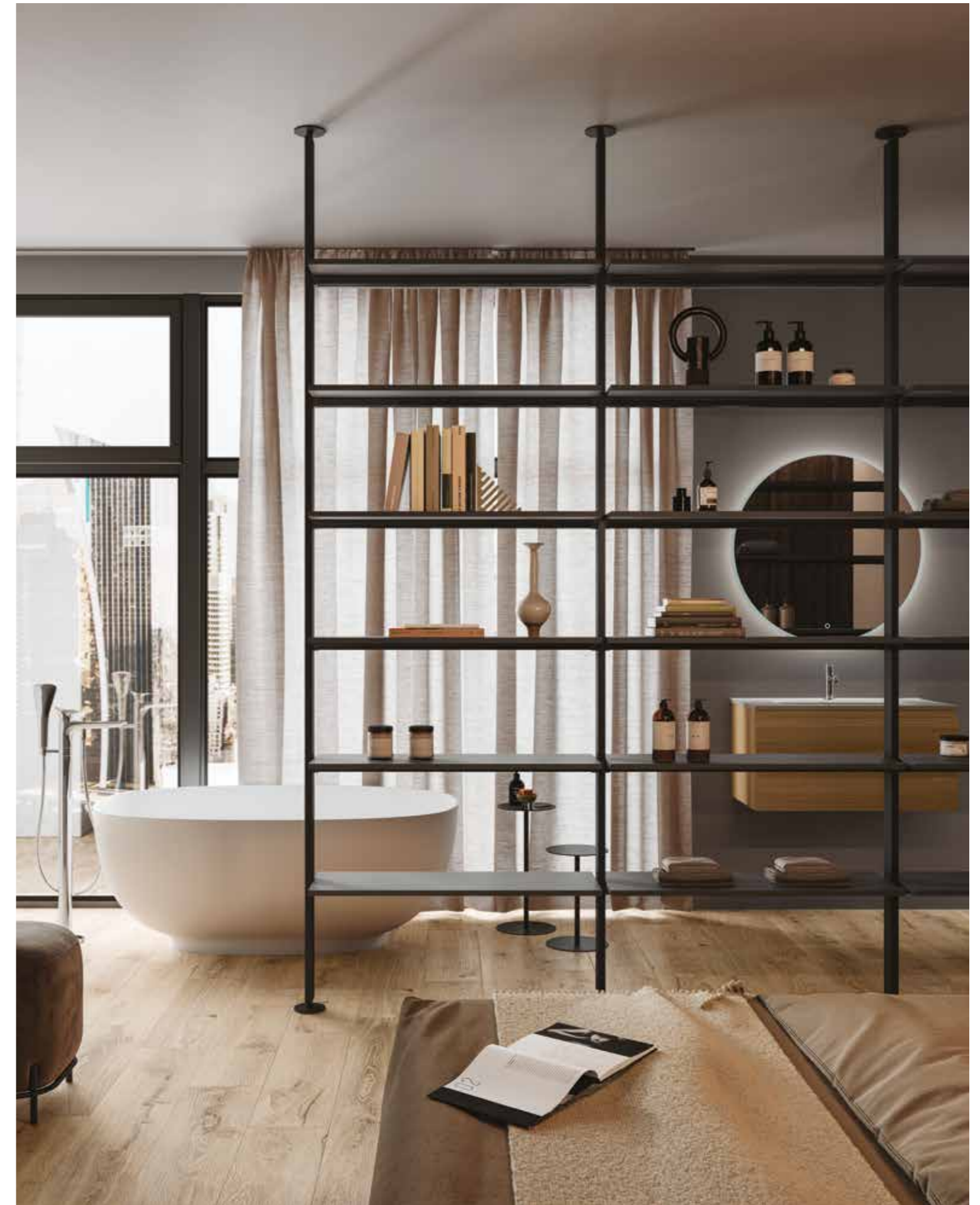



RAK CERAMICS  
P.O. BOX 4714, Ras Al Khaimah,  
United Arab Emirates (U.A.E)  
Tel: +971 7 2467000  
Fax: +971 7 2445270  
Email: [info@rakceramics.com](mailto:info@rakceramics.com)

[RAKCERAMICS.COM](http://RAKCERAMICS.COM)

**RAK**  
CERAMICS