

# LAUFEN

bathrooms

# Lb3

m o d e r n

c l a s s i c

d e s i g n



**Lb<sup>3</sup> collection**  
*Three  
 bathroom designs  
 Das Bad –  
 in drei Designvarianten  
 La salle de bains –  
 trois variantes de design  
 Il bagno –  
 design in tre varianti*

02

*About the concept  
 Über das Konzept  
 Notre concept  
 Il concetto*

06

**modern**

*Pictures and impressions  
 Bilder und Impressionen  
 Images et impressions  
 Foto e impressioni*

38

*WCs and bidets  
 WCs und Bidets  
 WC et bidets  
 Vasi e bidet*

16

**classic**

*Pictures and impressions  
 Bilder und Impressionen  
 Images et impressions  
 Foto e impressioni*

44

*Bathtubs and shower trays  
 Badewannen und Duschen  
 Baignoires et douches  
 Vasche e docce*

30

**design**

*Pictures and impressions  
 Bilder und Impressionen  
 Images et impressions  
 Foto e impressioni*

52

*Furniture and accessories  
 Möbel und Accessoires  
 Mobilier et accessoires  
 Mobili e accessori*

64

*Faucets  
 Armaturen  
 Robinetterie  
 Rubinetti*

# Life's too short for just one style

*Das Leben ist zu kurz für einen einzigen Stil  
La vie est trop courte pour ne jamais changer de style  
La vita è troppo breve per un solo stile*

**INTERIOR DESIGN** is far more exciting than the stylish interiors in glossy magazines would have us believe. Our homes are not just reflections of isolated moments in our lives, but in fact a colorful mélange of experiences, ideas and objects we've picked up on the way. LAUFEN's bathroom concept for living is called Lb3.

No ready-made solutions please. After all, you only live once – and so you decide what your bathroom should look like. LAUFEN offers you Lb3 and the freedom to create a new look again and again. The Milanese architects Ludovica+Roberto Palomba have spent more than a year looking at contemporary styles in cities all over the globe. They have come to some fascinating conclusions. Rigid style con-

cepts are out and free interpretation and improvisation are in. Lb3, with its modern, classic and design lines, offers the perfect backdrop.

**MODERN** pleads for formal, yet undogmatic adherence to the architectural era of the same name. It suggests a sense of style without sticking to strict guidelines. This Lb3 line is the style preferred by today's men and women who have learned to stand on their own two feet.

**CLASSIC** A rapprochement of the style from the Belle Époque with the designer bathroom. For all those drawn to the appeal of 19th century interiors but who still want good design in a bathroom.

**DESIGN** This Lb3 type is a bathroom that fits into no particular category. Ur-

ban living combined with metropolitan flair. For aficionados of design who are also individualists with their own flair.

**WOHNEN** ist weit aufregender als es die feingemachten Räume in den Hochglanzmagazinen glauben machen wollen. Und: Wohnen ist keine Momentaufnahme, sondern ein buntes Sammelsurium von Erfahrungen, Ideen und Fundstücken. LAUFEN hat das Bad-Konzept zum Wohnen: Es heisst Lb3. Bitte kein Stil von der Stange! Das Leben ist Ihr Wunschkonzert – und wie Sie baden möchten, entscheiden allein Sie selbst. LAUFEN bietet Lb3 und damit die Freiheit, die Lebenswelt immer wieder neu zu kombinieren. Die Mailänder Architekten Ludovica+Roberto Palomba haben dafür über ein Jahr lang das Wohnen im Hier und Jetzt erforscht – in vielen Metropolen dieser Welt. Und sie haben faszinierende Erkenntnisse gewonnen. Nieder mit dem Stildiktat – es lebe die freie Interpretation und Improvisation! Lb3 bietet Ihnen mit den Varianten modern, classic und design die passende Plattform dafür.

**MODERN** predigt die formale Zurückhaltung der gleichnamigen Architekturepoche – und zwar ganz undogmatisch. Stilsicherheit ohne Stildiktat: Diese Variante von Lb3 ist die Stilpräferenz für Kinder der Moderne, die gelernt haben, auf eigenen Füßen zu stehen.

**CLASSIC** Stuckfries trifft Designbad: Endlich ein Bad der guten Form – für die Bel Etage aus der Belle Époque. Und für alle, die Wohnwelten aus dem 19. Jahrhundert schön finden, ohne auf Designanspruch verzichten zu wollen.

**DESIGN** Die Lb3 Variante design ist das Bad von Welt, das in keine Schublade passt. Wohnen urban und mit weltstädtischem Flair. Für alle, die Design lieben – aber nicht um den Preis, dass sich daraus kein eigener Stil entwickeln lässt.



Ludovica+Roberto Palomba

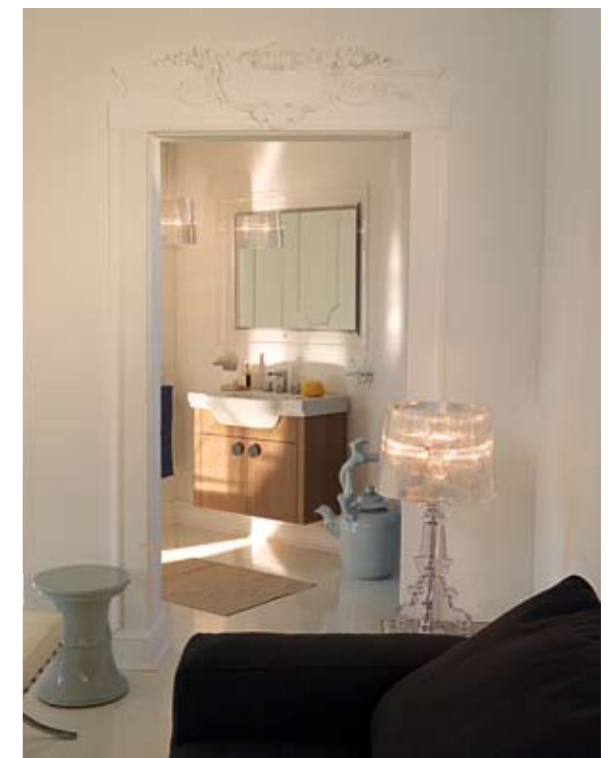

**L'ART DE VIVRE** est bien plus excitant que ne le laissent supposer les pièces immaculées des magazines sur papier glacé. Et l'art de vivre ne correspond pas à un état immuable, mais à un capharnaüm chamarré d'expériences, d'idées et de trouvailles. LAUFEN vous présente le concept de salle de bains agréables à vivre: c'est le concept Lb3. Pas de style prêt-à-porter! La vie, c'est vous qui la créez – et c'est à vous de décider comment vous voulez prendre

vos bains. LAUFEN vous propose Lb3 et par conséquent la liberté de créer et de recréer votre espace de vie en une multitude de combinaisons. A cet effet, les architectes milanais Ludovica+Roberto Palomba ont étudié pendant plus d'un an l'art de vivre actuel dans de nombreuses métropoles du monde. Ils sont parvenus à des conclusions fascinantes. Halte au diktat du style, vive l'interprétation libre et l'improvisation! Lb3 vous offre la pla-

teforme adéquate avec les variantes modern, classic et design.

**MODERN** propose une forme toute en retenue, propre à l'époque architecturale du même nom, et ce, sans nul dogmatisme. Sûr et sans diktat, le style de cette variante de Lb3 est le préféré des adeptes de l'art moderne qui ont appris à affirmer leurs propres goûts.

**CLASSIC** ou la rencontre de la frise en stuc et de la salle de bains design: enfin une salle de bains de belles formes –

pour le Bel Etage de la Belle Époque. Et pour tous ceux qui aiment l'ambiance des intérieurs du 19<sup>e</sup> siècle sans vouloir renoncer au design.

**DESIGN** La variante design de Lb3 est une salle de bains moderne et inclassable. Style d'intérieur urbain et cosmopolite. Pour tous ceux qui aiment le design, mais pas au prix d'un renoncement à leur propre style.

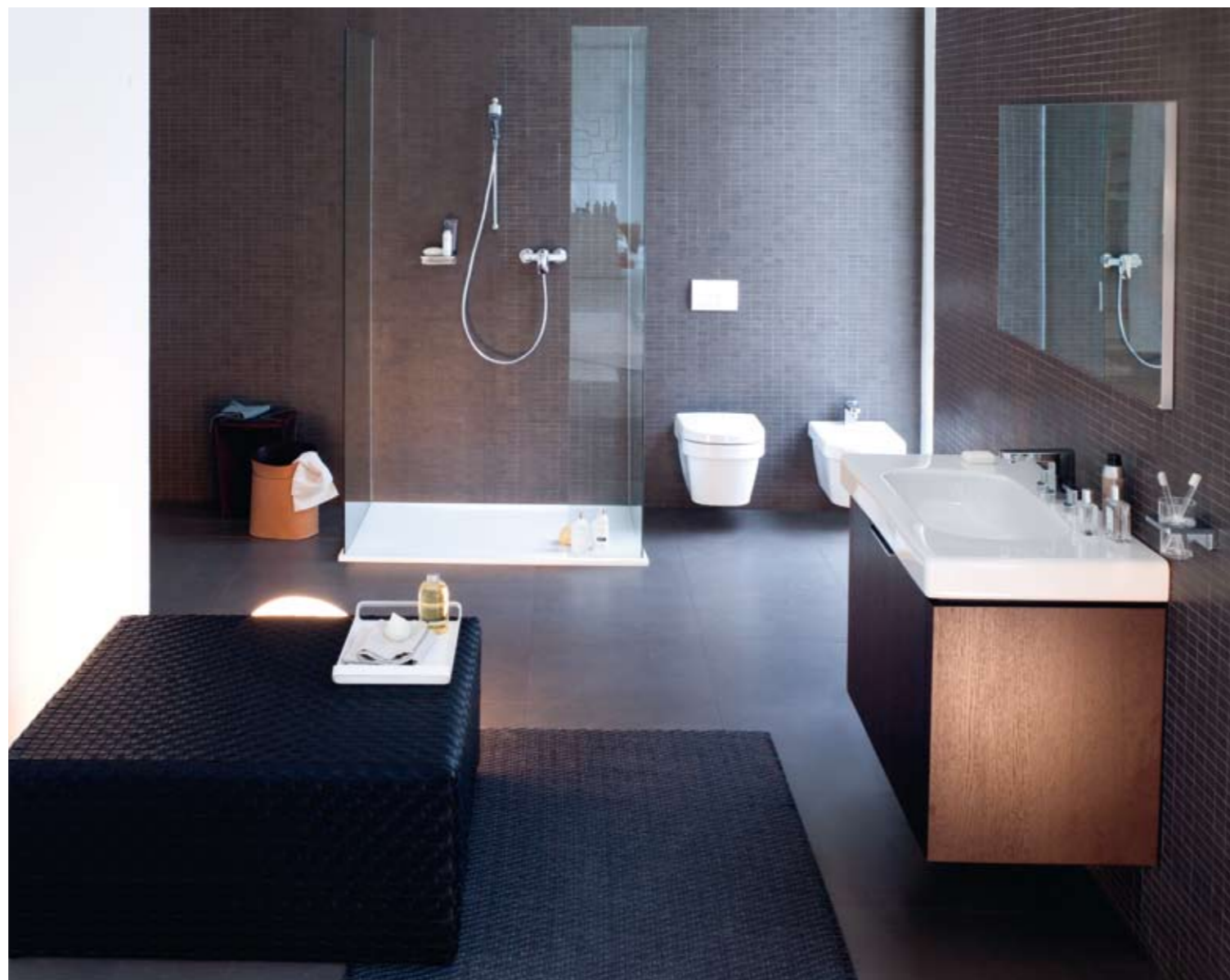

**L'ARTE DI ABITARE** è molto più emozionante di quanto vorrebbero farci credere i ricercati ambienti delle riviste patinate. L'arte di abitare, inoltre, non è un'istantanea immobilizzata nel tempo, ma un colorato insieme di esperienze, idee e scoperte. LAUFEN ha sviluppato l'idea perfetta di bagno da abitare: si chiama Lb3. Bando agli stili ordinari! La vita è un concerto su richiesta – e la vostra idea di bagno è una scelta personale. LAUFEN vi offre Lb3 e quindi la libertà di combinare il mondo in cui

vivate in maniera sempre nuova. Gli architetti milanesi Ludovica+Roberto Palomba hanno studiato per più di un anno lo stile di vita del momento in varie metropoli internazionali, ricavandone idee affascinanti. Abbasso i dettami dello stile – viva la libera interpretazione e l'improvvisazione! Con le varianti modern, classic e design, Lb3 vi offre la piattaforma perfetta per ogni vostra idea.

**MODERN** proclama la reticenza formale dell'omonima epoca architettoni-

ca – in maniera del tutto adogmatica. Stile sicuro senza dettami categorici: questa variante di Lb3 è lo stile preferito dei figli della modernità che hanno imparato a camminare con le proprie gambe.

**CLASSIC** Il fregio in stucco incontra il design moderno: finalmente un bagno dalle belle forme – per il Bel Étage della Belle Époque. E per tutti coloro che amano le atmosfere dell'Ottocento, senza dover rinunciare al gusto del design.

**DESIGN** La variante Lb3 design è il bagno disinvolto che non si lascia etichettare. L'arte di abitare con stile urbano e gusto cosmopolita. Per tutti coloro che amano il design – ma non a costo di rinunciare ad uno stile personale.



Lb<sup>3</sup> modern



## Modernism is everywhere

Die Moderne ist allgegenwärtig  
L'art moderne est omniprésent  
La modernità è onnipresente

Modernism is the 20<sup>th</sup> century's major design movement and Lb3 modern is its fun and uncomplicated reflection. modern is not a credo or a philosophy, but simply implies well-thought out shapes and functionality.

Die Moderne ist die grosse Designbewegung des 20. Jahrhunderts. Lb3 modern zitiert sie spielerisch und unbefangen. modern ist kein Glaubensbekenntnis und keine Weltanschauung, sondern einfach gute Form mit einfach guter Funktion.

L'art moderne est le grand mouvement design du 20<sup>e</sup> siècle. Lb3 modern s'en inspire de façon enjouée et ingénue. modern ne constitue pas une profession de foi ou une idéologie, mais allie tout simplement harmonie des formes et fonctionnalité.

La modernità è il grande movimento di design del 20° secolo. Lb3 modern si ispira alla modernità in modo giocoso e leggero. modern non è una confessione di fede, né una filosofia di vita, ma semplicemente armonia di forme e funzionalità.



**The infinite ease of the design: the light Lb3 design with console and chrome plated towel rail.**

**La légèreté infinie du design: construction Lb3 aérienne avec meuble-console et porte-serviettes chromé.**

**Die unendliche Leichtigkeit des Designs: Luftige Lb3-Konstruktion mit Möbelkonsole und verchromter Handtuchreling.**

**L'infinita leggerezza del design: ariosa progettazione Lb3 con mobili sospesi e barra portasciugamani cromata.**







Showcase the place you wash as a pure ceramic icon with a pedestal or in combination with sophisticated-looking wood. Lb3 opens up a world of opportunities.

Inszenieren Sie den Waschplatz als sortenreine Keramik-Ikone mit Standsäule oder in Kombination mit edlen Hölzern. Lb3 eröffnet eine Fülle von Möglichkeiten.

Mettez en scène votre solution lavabo sous forme d'icône pure en céramique sur pied ou combinée à des essences de bois précieuses. Lb3 vous offre une large palette de possibilités.

Ideate l'area lavabo come pura icona in ceramica, con colonna integrata o in combinazione con legni pregiati. Lb3 offre un ampio spettro di possibilità.

Thanks to Clou, the special overflow technology, Lb3 ceramics do not require an overflow hole – so they are hygienic and look attractive.

Dank der speziellen Überlauftechnik Clou kommt Lb3 Keramik ohne Überlaufloch aus – ästhetisch und hygienisch optimal.

Grâce à la technique spéciale de trop-plein Clou, la céramique Lb3 peut ne pas être percée, une solution optimale pour l'esthétique et l'hygiène.

Grazie alla particolare tecnica di protezione antiriboccamento Clou, le ceramiche Lb3 non necessitano di foro del troppopieno – una soluzione ideale dal punto di vista estetico, oltre che igienico.







Stand-alone: washbasins on compact vanity units with wood veneers of white, oak or wenge. Stand-alone: lavabos sur meubles bas compacts à placage en bois blanc, chêne ou wengé.

Stand-alone: Waschtische auf kompakten Unterschränken in den Holzfarben Weiss, Eiche oder Wenge. Stand-alone: lavabo su compatta colonna basse impiallacciate color bianco, rovere o wengé.

Lb<sup>3</sup> classic





## Options for the Bel Etage

Optionen für die Bel Etage  
Options pour le Bel Etage  
Opzioni per il Bel Étage

Combines well with contemporary furnishing: Lb3 classic, that is style of the bourgeois of the 19th century – brought into the present and not capricious.

Kombiniert sich perfekt mit zeitgenössischer Möblierung: Lb3 classic, das ist die Formensprache der bürgerlichen Wohnwelten des 19. Jahrhunderts – in die Gegenwart übertragen und unkapriziös.

Combinaison parfaite avec le mobilier contemporain: Lb3 classic, voilà les formes des intérieurs bourgeois du 19<sup>e</sup> siècle, transposées au présent tout simplement.

Si combina perfettamente con mobili in stile contemporaneo: Lb3 classic, il linguaggio formale della casa borghese dell'Ottocento – trasferito nel presente e niente affatto capriccioso.



**Classical style:** the double contour allows the classic washbasin to appear elegant and light.

**Les lignes classiques:** le double profil confère au lavabo classic son style élégant et léger.

**Klassische Formensprache:** Die doppelte Kontur lässt den classic-Waschtisch zeitlos elegant und leicht wirken.

**Classico linguaggio formale:** il doppio contorno conferisce al lavabo classic un'eleganza leggera e senza tempo.





Timeless: the spacious Lb3 classic washbasin is available with a siphon cover or pedestal, which elegantly covers the plumbing underneath.

Zeitlos wertig: Der voluminöse Waschtisch Lb3 classic ist erhältlich mit Siphonverkleidung oder Säule, die die Anschlüsse elegant verdecken.

Précieux et intemporel: le lavabo volumineux Lb3 classic est disponible avec cache-siphon ou colonne qui dissimulent élégamment la robinetterie.

Un valore intramontabile: il voluminoso lavabo Lb3 classic è disponibile con semicolonna o colonna, ideale per coprire elegantemente gli elementi dei raccordi.

Tailor-made ceramics: the shelves at the side of the washbasin are available in various sizes.

Céramique sur mesure: les surfaces latérales du lavabo sont disponibles en différentes tailles.

Keramik auf Mass: Die seitlichen Ablagen des Waschtischs sind in diversen Wunschlängen lieferbar.

Ceramica su misura: i ripiani laterali del lavabo sono disponibili in varie lunghezze.





A compliment to the past – at the same time right up to date. Furniture in white, oak and wenge.

Un hommage au passé et un design tout à fait actuel. Combiné à des meubles en blanc, chêne ou wengé.

Ein Kompliment an die Vergangenheit – und dabei im Design hochaktuell. Dazu Möbel in Weiss, Eiche oder Wenge.

Un omaggio al passato – in un design di grande attualità a cui si aggiungono mobili in bianco, rovere o wengé.





Surfaces, flexible seating and rolling storage space: the trolley with artificial leather cushion.

Tablette, siège d'appoint flexible et espace de rangement roulant: container à roulettes avec coussin en skaï.

Ablagefläche, flexible Sitzgelegenheit und rollender Stauraum: Der Rollcontainer mit Kunstlederpolster.

Superficie di appoggio, sedile flessibile e portaoggetti mobile: la base su ruote con cuscino imbottito in similpelle.



As a drop-in washbasin that integrates perfectly or a stand-alone washbasin: the Lb3 classic range has a variety of ceramics to choose from.

Ob als Einbauwaschtisch, der sich einfügt, oder als Standwaschtisch, der sich anlehnt: Das Lb3 classic-Sortiment bietet alle keramischen Möglichkeiten.

Lavabo à encastrer ou lavabo indépendant à adosser: la gamme Lb3 classic offre toutes les possibilités céramiques.

Lavabo da incasso, che si integra nell'ambiente, o come lavabo a pavimento, che si appoggia leggero: la gamma Lb3 classic offre ceramiche in tutte le varianti.

LAUFEN / Lb<sup>3</sup>

Lb<sup>3</sup> design







Cubes and soft edges define the style of Lb3 design. The generous use of ceramics creates value for years to come.

Le cube et les arêtes douces sont les formes typiques de Lb3 design. La céramique volumineuse constitue une valeur sûre à long terme.

Kubus und weiche Kanten sind charakteristisch für die Formensprache von Lb3 design. Voluminöse Keramik schafft Wertigkeit für lange Jahre.

Cubi e bordi morbidi sono una caratteristica del linguaggio formale di Lb3 design. La voluminosa ceramica assicura lunghi anni di piacere nel bagno.

## *A compliment to international living*

Kompliment an das internationale Wohnen  
Hommage à l'art de vivre international  
Omaggio all'arte di abitare internazionale

This interior design ploy works in a rural setting too. Lb3 design is a compliment to contemporary living in the world's metropolises.

Dieser Einrichtungs-Trick funktioniert auch auf dem Land: Lb3 design ist ein Kompliment an das zeitgenössische Wohnen in den Metropolen dieser Welt.

Cette astuce fonctionne également pour aménager les espaces à la campagne: Lb3 design est un hommage à l'art de vivre contemporain dans les métropoles du monde.

Questo trucco d'arredo funziona anche fuori città: Lb3 design è un omaggio all'abitare contemporaneo nelle metropoli del mondo moderno.

LAUFEN / **Lb<sup>3</sup>**







Lb3 design – bathroom furniture en bloc: the discreet handle on the drawer makes storage space accessible.

Lb3 design – meubles de salle de bains en bloc: la poignée discrète intégrée au tiroir permet d'accéder à l'espace de rangement.

Lb3 design – Badmöbel en bloc: Die dezente Griffleiste an der Schublade macht den Stauraum zugänglich.

Lb3 design – mobili da bagno in blocco: la discreta maniglia del cassetto offre accesso alla capiente base sottolavabo.



Lb3 design provides a washbasin concept that doesn't fit in any category. An understanding of design that applies internationally and falls under no particular category – except perhaps that it suggests good taste.

Lb3 design bietet ein Waschtischkonzept, das in keine Schublade passt. International gültiges Designverständnis, das sich nicht einordnen lässt – ausser vielleicht unter gutem Geschmack.

Lb3 design offre un concept de lavabo hors du commun. Notre concept de design universellement reconnu n'entre dans aucune catégorie – sauf dans celle du bon goût.

Lb3 design è un progetto di lavabo che non si lascia etichettare. Concezione di design valida a livello internazionale, che non si lascia classificare in categorie – ad eccezione forse di quella del buon gusto.



Lb3 ceramics without an overflow – although still overflow-proof thanks to Clou, our technical solution.

Céramique Lb3 sans trou de trop-plein et pourtant résistante au trop-plein grâce à la solution technique Clou.

Lb3 Keramik ohne Überlauf-Loch – trotzdem überlaufesicher dank der Techniklösung Clou.

La ceramica Lb3 senza foro di troppopieno, eppure ugualmente sicura grazie alla soluzione tecnica Clou.



Lb<sup>3</sup> WC / bidet





## Clever shapes in all the types

Für alle Varianten: eine gute Form  
Pour toutes les variantes: une forme harmonieuse  
Per tutte le varianti: una forma armoniosa



The WC cover makes the difference: the classic variation has a double contour. On the other hand, the WC and bidet ceramic range is identical in all Lb3 types.

Der WC-Deckel macht den Unterschied: Die classic-Variante nimmt die doppelte Kontour auf. Die WC und Bidet Keramiksortimente hingegen sind bei allen Lb3-Varianten identisch.

C'est l'abattant des WC qui fait la différence: la variante classic reprend le double profil. La gamme des WC et des bidets en céramique par contre est identique pour toutes les variantes Lb3.

Il copri water fa la differenza: la variante classic riprende il contorno doppio. La gamma di ceramiche per vasi e bidet, invece, è identica in tutte le varianti Lb3.



Whether standalone or wall-hanging, with concealed or under-wall cistern: the versatility of the Lb3 WC and bidet range is exceptional – with or without softclose cover.

Ob stehend oder wandhängend, ob mit Vorwand- oder Unterputzspülkasten: Das Lb3 WC- und Bidet-Sortiment überzeugt durch Vielfalt – mit oder ohne Softclose-Deckel.

Au sol, suspendu, à réservoir d'eau mural ou encastré: la gamme des WC et des bidets Lb3 convainc par sa variété – avec ou sans abattant Softclose.

Sia nella versione a pavimento che in quella sospesa, sia con una cassetta di sciacquo a vista, che murata: l'assortimento di vasi e bidet Lb3 convince grazie alla diversità – con o senza copri water Softclose.



The details are impressive: bidet overflow without overflow hole, WC-seat with antibacterial effect and covered attachments on the WC and bidet.

Les détails sont convainquants: trop-plein sans trou pour bidet, siège WC avec effet antibactérien et fixations cachées pour WC et bidets.

Die Details überzeugen: Bidet-Überlauf ohne Überlaufloch, WC-Sitz mit antibakterieller Wirkung und verdeckte Befestigungen bei WC und Bidet.

Sono i dettagli che convincono: troppopieno senza foro per bidet, sedile con effetto antibatterico ed elementi di fissaggio nascosti per vasi e bidet.



Lb<sup>3</sup> bathtubs / shower trays







The Lb3 bathtubs are made of high quality sanitary acrylic and covered with real wood veneer (white, oak, wenge).

Die Lb3 Wannen sind aus hochwertigem Sanitäracryl gefertigt und mit Echtholz furnier (Weiss, Eiche, Wenge) verkleidet.

Les baignoires Lb3 sont réalisées en acrylique sanitaire de haute qualité et plaquées en bois véritable (blanc, chêne, wengé).

Le vasche Lb3 sono realizzate in acrilico sanitario di alta qualità e rivestite con vero legno impiallacciato (bianco rovere, wenge).



## Pure comfort in your own bathroom

Baden in heimischen Gefilden  
 Prendre un bain chez soi  
 Bagno in terra natia



The details are exceptional: step with handle, innovative self adhesive and waterproof gel pillow and the faucet rim integrated into the tub rim.

Les détails sont convainquants: marche-pied avec poignée, coussin-gel innovant, adhérent et résistant à l'eau, et ensemble robinetterie intégré dans le rebord de la baignoire.

Die Details überzeugen: Einstiegshilfe mit Griff, innovatives, selbsthaftendes und wasserfestes Gelkissen und das im Wannenrand integrierte Armaturenbor-

Sono i dettagli che convincono: scalino con comoda maniglia di supporto, innovativo cuscino in gel autoadesivo e resistente all'acqua e rubinetteria integrata nel bordo della vasca.



Impressively flat: the shower tray made of sanitary acrylic is almost edgeless. It is only 1.5 cm thick – ideal for flat construction and floor-level installation solutions.

Beeindruckend flach: Die Duschwanne aus Sanitäracryl ist nahezu randlos. Sie ist nur 1,5 cm stark – optimal für flache Aufbau- und bodenebene Einbaulösungen.

Une solution d'une finesse recherchée: le receveur de douche en acrylique sanitaire a un rebord réduit au minimum. Son épaisseur est de 1,5 cm seulement – la solution optimale à encaster ou à poser.

Incredibilmente sottile: il piatto doccia in acrilico sanitario è praticamente privo di bordi. È spesso solo 1,5 cm – ideale per soluzioni di installazione molto livellate e a filo pavimento.



Lb3 shower tray and Lb3 bathtubs have a hidden drain: making standing, sitting and cleaning more comfortable.

Les receveurs de douche Lb3 et les baignoires Lb3 sont équipés d'un trop-plein dissimulé: surface plane, confortable et facile à nettoyer.

Lb3 Duschwannen und Lb3 Wannen verfügen über einen verdeckten Ablauf: tritt- und sitz-, aber auch reinigungs-freundlich.

Il piatto doccia Lb3 e le vasche Lb3 dispongono di piletta nascosta: non solo di facile accesso, ma anche estremamente semplici da pulire.

**Lb<sup>3</sup>** furniture, mirrors,  
lamps and accessories





Optional feet, wall mounting possible: the cabinets with glass shelves conceal a multitude of objects and allow the bathroom to appear permanently tidy.

Möbelfüsse als Option, Wandmontage möglich: Die Hochschränke mit Glastablen stecken einiges weg und sorgen für dauerhaft aufgeräumte Badezimmer.

Pieds pour meubles en option, possibilité de montage au mur: les armoires à tablettes en verre ont une grande capacité et vous garantissent toujours une salle de bains rangée.

Piedini opzionali, possibile montaggio a parete: le colonne, con i loro ripiani interni in vetro, offrono capienza a volontà e permettono di tenere in ordine il bagno.

**Trolley:** mobile seating with drawer.

**Container à roulettes:** siège mobile équipé de tiroir.

**Rollcontainer:** Mobile Sitzgelegenheit mit Schublade.

**Base su ruote:** sedile mobile con cassetto.



LAUFEN / Lb<sup>3</sup>





Modular mirror system for a combination of mirrors: you can create your own mirror from the Lb3 components.

Spiegel-Rastersystem zum freien Kombinieren: Aus den Lb3 Bausteinen setzen Sie sich Ihren Wunsch-Spiegelschrank zusammen.

Système de miroir variable permettant de combiner librement: vous réaliserez à partir des éléments Lb3 votre armoire de toilette telle que vous la désirez.

Sistema specchio modulare per combinare liberamente i vari elementi: con i componenti Lb3 si può creare il proprio armadietto a specchio personalizzato.

The open shelves on the front or side of the mirror cupboard allow you to be imaginative.

Les étagères ouvertes sur le devant de l'armoire de toilette ou sur le côté laissent libre cours à votre créativité.

Die offenen Regale an der Spiegelschrankfront oder an der Seite erlauben individuelle Lösungen.

Gli scaffali aperti posti di fronte o ai lati dell'armadietto a specchio permettono di realizzare soluzioni individuali.



# Lb<sup>3</sup> units

*Tailor-made combinations*  
*Kombination ganz nach Wunsch*  
*Vous avez toute liberté de combiner*  
*Combinazioni secondo il proprio gusto*

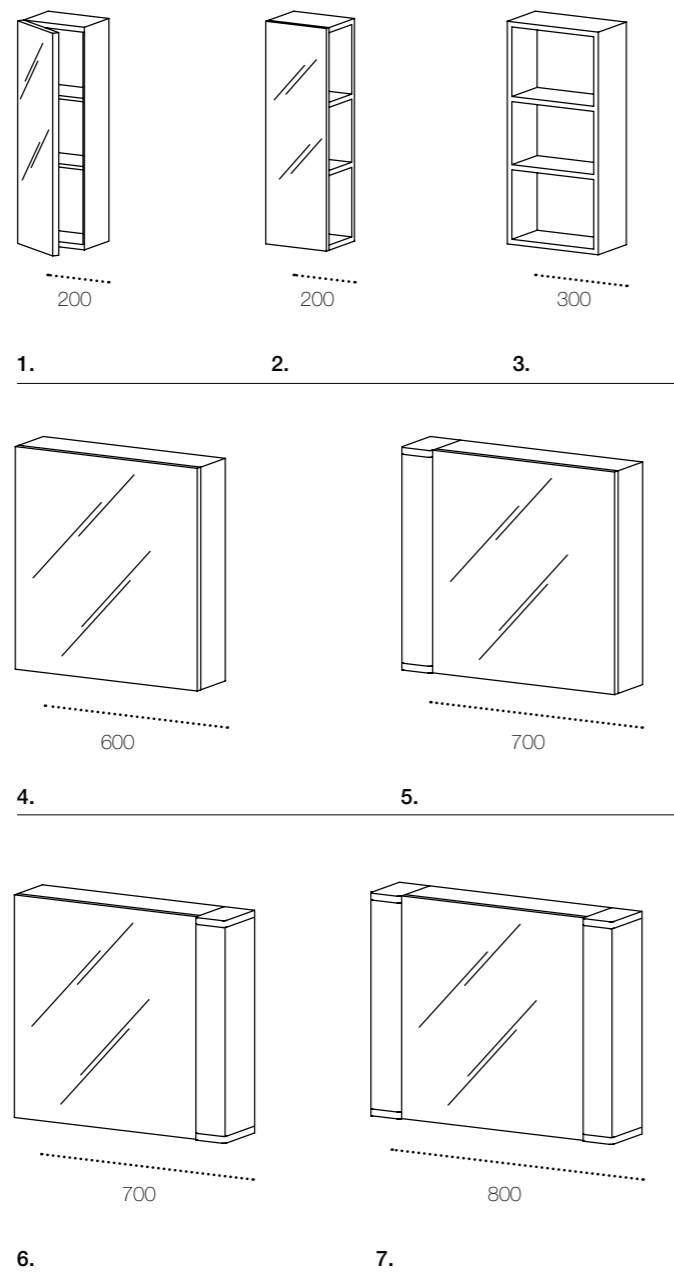

The Lb3 furniture concept is based on a clear, veneered basic form with two different handles – circular knobs or discreet handles. Its purpose: to tidy the bathroom. Its strength: the modular design, which fits into any shape of bathroom. In addition, there is a variety of mirrors, lighting and accessories available.

Das Lb3 Möbelkonzept basiert auf einer klaren, mit Holz furnier belegten Grundform und zwei unterschiedlichen Griffen – kreisrunde Knöpfe oder dezente Griffleisten. Seine Aufgabe: Das Bad aufräumen. Seine Stärke: Die Modularität, die jedem Badgrundriss gerecht wird. Dazu passend gibt es eine Vielfalt an Spiegeln, Leuchten und Accessoires.

Le concept des meubles Lb3 est conçu à partir d'une forme de base combinée à un placage bois et à deux modèles de poignées différents, soit des boutons ronds, soit des listels discrets. Objectif: ranger la salle de bains. Avantages du concept: sa modularité qui permet de l'adapter au plan individuel de toute salle de bains. Un grand nombre de miroirs, de lampes et d'accessoires adaptés sont disponibles.

Il progetto dei mobili Lb3 è basato su una chiara forma di base, rivestita in legno impiallacciato e con due diversi tipi di maniglie – pomelli rotondi o manici sottili e discreti. La sua missione: tenere in ordine il bagno. La sua forza: la modularità, che si adatta alla pianta di ogni ambiente. Vi si intona armoniosamente la serie di specchi, lampade e accessori.

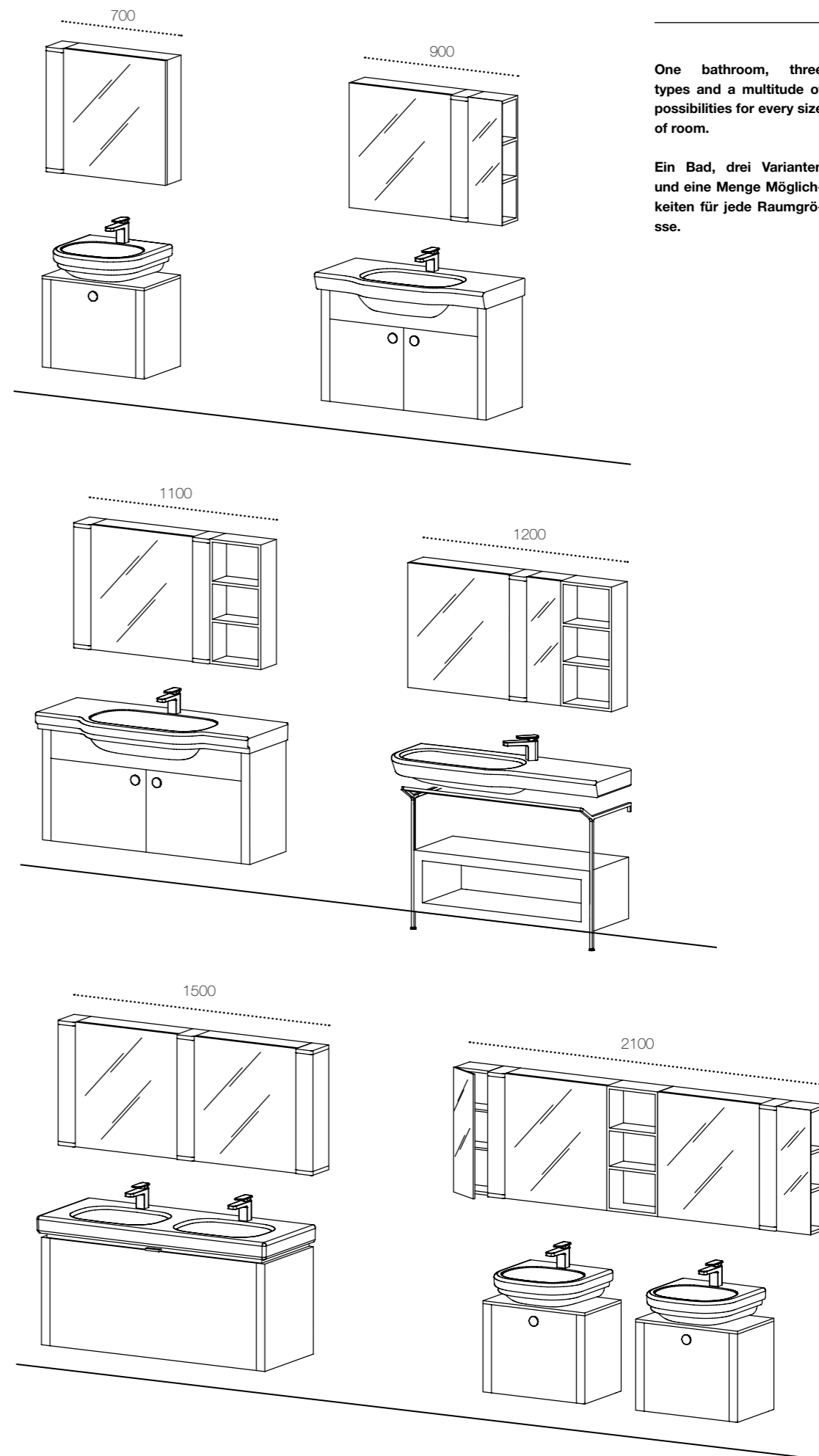

One bathroom, three types and a multitude of possibilities for every size of room.

Une salle de bains, trois variantes et un grand nombre de solutions pour toute superficie.

Ein Bad, drei Varianten und eine Menge Möglichkeiten für jede Raumgröße.

Un bagno, tre varianti e un vasto spettro di possibilità per stanze di tutte le dimensioni.



## Lb<sup>3</sup> accessories

# Details that make the difference

Die nützlichen Kleinigkeiten  
Les accessoires utiles  
Pratici accessori



Lb3 accessories are designed to make life easier. These useful little items keep everything within reach, tidy and easy to locate. Not only do they organise our bathroom, they also leave us free to concentrate on the important things in life.

Das Zubehör von Lb3 macht den Alltag einfacher. Mit Hilfe dieser nützlichen Kleinigkeiten ist alles in greifbarer Nähe, aufgeräumt und wieder auffindbar. Damit organisieren sie nicht nur unser Bad, sondern auch unseren Geist – er gewinnt Freiraum, sich auf das Wesentliche zu konzentrieren.

Les accessoires Lb3 rendent le quotidien plus facile. Grâce à ces petits détails, tout se trouve à portée de main, tout est bien rangé et facile à retrouver. Cela vous permet non seulement d'organiser votre salle de bains, mais aussi de libérer votre esprit et de vous concentrer sur ce qui est important.

Gli accessori di Lb3 semplificano i gesti quotidiani. Grazie a queste pratiche rifiniture è tutto a portata di mano, in ordine e facile da ritrovare. Gli oggetti non solo organizzano il nostro bagno, ma permettono al nostro spirito di distendersi e concentrarsi sull'essenziale.





- 01. Towel rail** / Handtuchhalter / Porte-serviettes / Portasciugamani
- 02. Towel rack** / Handtuchablage / Etagère porte-serviettes / Ripiano per asciugamani
- 03. Towel hook** / Handtuchhaken / Crochet de serviette / Gancio portasciugamani
- 04. Toilet roll holder** / WC-Papierhalter / Porte-papier / Portarotolo
- 05. Toilet brush holder** / Bürstengarnitur / Porte-balai / Portascopino
- 06. Crystal glass holder** / Kristallglashalter / Porte-verre en cristal / Portabicchiere di cristallo
- 07. Crystal glass holder** / Kristallglashalter / Porte-verre en cristal / Portabicchiere di cristallo
- 08. Crystal soap dispenser** / Kristallseifendispenser / Distributeur de savon en cristal / Dispenser portasapone di cristallo
- 09. Crystal soap dish** / Kristallseifenschale / Porte-savon en cristal / Portasapone di cristallo

Many things have to be accessible and stored in every bathroom. The accessories range matches the three Lb3 types perfectly and is available in chrome.

In jedem Bad gibt es eine Menge Dinge zu verstauen oder bereitzuhalten. Das Zubehörprogramm von Lb3 passt im Design perfekt zu den drei Lb3 Varianten und ist in edlem Chrom gehalten.

Dans toute salle de bains, il y a beaucoup de choses à ranger ou à avoir sous la main. Le design du programme d'accessoires pour Lb3 est en harmonie parfaite avec les trois variantes Lb3; ces accessoires sont réalisés en chrome précieux.

In ogni bagno vi sono tante cose da tenere in ordine e a portata di mano. Il design del programma di accessori Lb3 si adatta perfettamente alle tre varianti Lb3 ed è realizzato in elegante metallo cromato.



- 10. Double crystal glass holder** / Doppell-Kristallglashalter / Double porte-verre en cristal / Portabicchiere di cristallo doppio
- 11. Combo crystal soap dish and glass** / Kombi Kristallseifenschale und Glas / Jeu de porte-savon en cristal et porte-verre / Set portasapone di cristallo e bicchiere
- 12. Combo crystal soap dispenser and glass** / Kombi Kristallseifendispenser und Glas / Jeu de distributeur de savon en cristal et verre / Set dispenser portasapone di cristallo e bicchiere
- 13. Metal shelf** / Metallablage / Etagère en métal / Mensola di metallo
- 14. Crystal glass shelf** / Kristallglasablage / Etagère en verre de cristal / Mensola di vetro in cristallo





## Lb<sup>3</sup> faucets

*About water sources  
 Von den Wasserspendern  
 A propos des systèmes d'eau  
 A proposito dei sistemi per l'acqua*

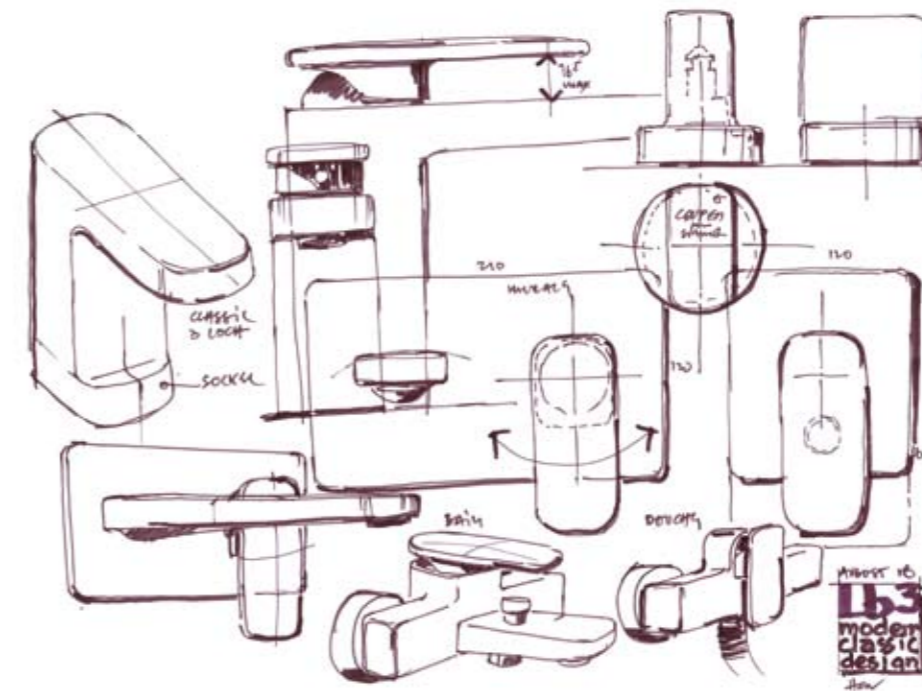

Jürg Heuberger



Form and function have a special relationship in the faucets from the Lb3 range. They were created by the architect and designer Jürg Heuberger and the SimilorGroup, the Swiss faucet specialists. A timeless design with trendsetting technology, the energy and water-saving Ecototal solution in the mixer system takes a green approach to this valuable resource.

Form und Funktion gehen bei den Armaturen von Lb3 eine besondere Verbindung ein. Verantwortlich zeichnen dafür Architekt und Designer Jürg Heuberger und die SimilorGroup, der Schweizer Armaturenspezialist. Ein zeitloser Entwurf mit zukunftsweisender Technik, denn die hier verwendete Ecototal-Technologie des Mischsystems erlaubt einen besonders energie- und wassersparenden Umgang mit dem wertvollen Nass.

La forme et la fonction constituent une synthèse particulière pour la robinetterie Lb3. C'est l'architecte et designer Jürg Heuberger ainsi que SimilorGroup, spécialiste suisse de la robinetterie, qui en sont les concepteurs. Un concept classique et une technique futuriste, car la technologie Ecototal du mitigeur permet une gestion particulièrement économe de l'énergie et de la ressource précieuse que constitue l'eau.

Forma e funzione si uniscono in un connubio speciale nella rubinetteria Lb3. Responsabile del progetto sono l'architetto e designer Jürg Heuberger e SimilorGroup, lo specialista svizzero della rubinetteria. Un design senza tempo con tecnologie avanzate, come Ecototal, qui utilizzata per il sistema di miscelazione che permette di risparmiare acqua ed energia.



The full range: the Lb3 faucet family has everything. From one-hole up to the three-hole right up to the tub rim and bath or shower mixer. With handshower and shower bar too.

Volles Programm: Die Lb3 Armaturenfamilie ist komplett. Vom Einloch über den Dreiloch bis hin zum Wannenrand und Bade- oder Duschenmischer. Dazu Handbrausen und Brausestange.

Un programme complet: la famille de robinetterie Lb3 propose tous les modèles. Du monotrou au trois trous, en passant par le modèle conçu pour le rebord de la baignoire, les mitigeurs de bains ou les mitigeurs de douche. Sans oublier la douchette et la barre de douche.

Programma completo: alla famiglia di rubinetti Lb3 non manca nulla: dal foro unico a quello triplo, dal miscelatore da bagno a quello per doccia. Ed inoltre doccette e aste di supporto per soffione.

The faucet bases vary: square-edged for the modern and design, rounded for the classic version.

Les bases de la robinetterie varient: à angle droit pour les modèles modern et design, et arrondies pour la ligne classic.

Die Armaturensockel variieren: kantig für modern und design, gerundet für die classic Ausführung.

Variazione di basi per rubinetti: angolare per modern e design, arrotondata nella versione classic.





# Lb3 by LAUFEN

modern



ø1268.1  
Small washbasin  
Handwaschbecken  
Lave-mains  
Lavamani

○/●

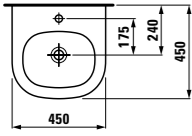
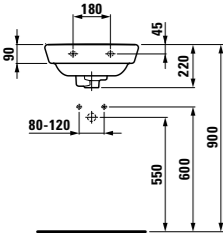
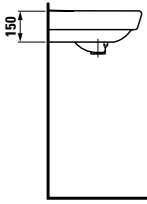
.104 .109

modern



ø1268.3  
Washbasin  
Waschtisch  
Lavabo  
Lavabo

○/●/●●●

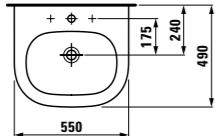
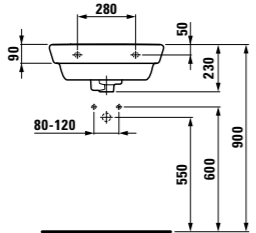
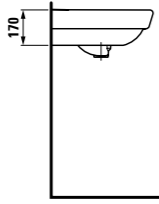
.104 .108 .109

modern



ø1268.3  
Washbasin  
Waschtisch  
Lavabo  
Lavabo

○/●/●●●

ø1968.0  
Pedestal, ceramic  
Säule, Keramik  
Colonne, céramique  
Colonna, ceramica

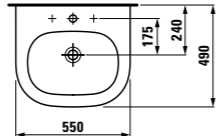
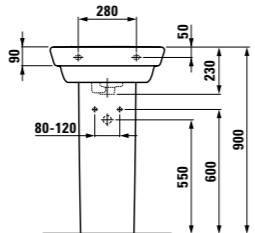
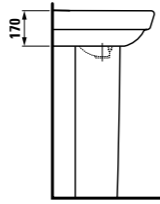
.104 .108 .109

modern



ø1268.3  
Washbasin  
Waschtisch  
Lavabo  
Lavabo

○/●/●●●

ø1968.1  
Siphon cover, ceramic  
Siphonverkleidung, Keramik  
Cache-siphon, céramique  
Semicolonna, ceramica

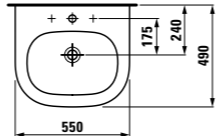
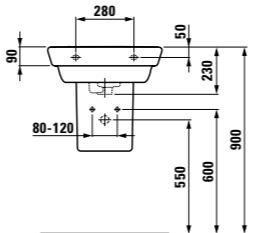
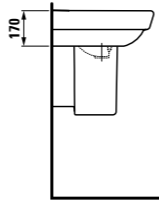
.104 .108 .109

# Lb3 by LAUFEN

modern



ø1268.4  
Washbasin  
Waschtisch  
Lavabo  
Lavabo

○/●/●●●

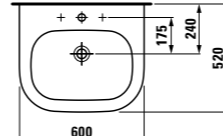
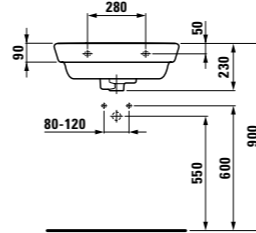
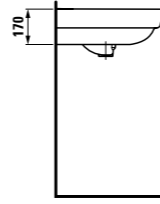
.104 .108 .109 .136

modern



ø1268.4  
Washbasin  
Waschtisch  
Lavabo  
Lavabo

○/●/●●●

ø1968.0  
Pedestal, ceramic  
Säule, Keramik  
Colonne, céramique  
Colonna, ceramica

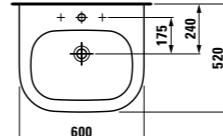
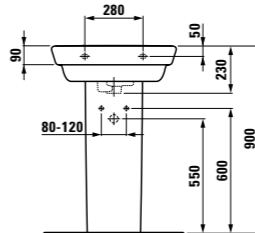
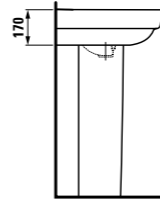
.104 .108 .109 .136

modern



ø1268.4  
Washbasin  
Waschtisch  
Lavabo  
Lavabo

○/●/●●●

ø1968.1  
Siphon cover, ceramic  
Siphonverkleidung, Keramik  
Cache-siphon, céramique  
Semicolonna, ceramica

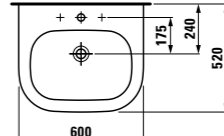
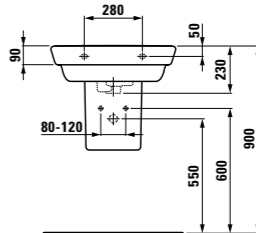
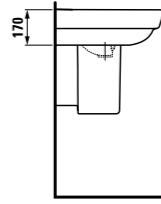
.104 .108 .109 .136

modern



ø1268.5  
Washbasin  
Waschtisch  
Lavabo  
Lavabo

○/●/●●●

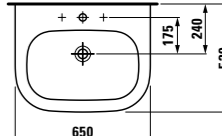
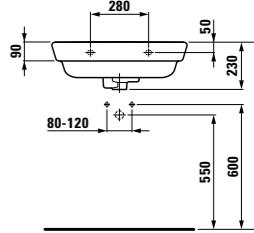
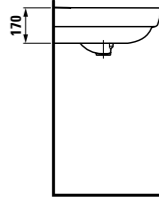
.104 .108 .109

Ceramic colours / Keramikfarben / Couleurs céramique / Colori della ceramica

□ .000 White / Weiss / Blanc / Bianco  
□ .400 White / Weiss / Blanc / Bianco LCC (Laufen Clean Coat)

■ .049 Pergamon / Pergamon / Pergamon / Pergamon

# Lb3 by LAUFEN



81268.5 ○/●/●●●  
**Washbasin**  
 Waschtisch  
 Lavabo  
 Lavabo

81968.0  
**Pedestal, ceramic**  
 Säule, Keramik  
 Colonne, céramique  
 Colonna, ceramica

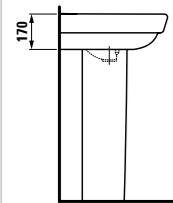
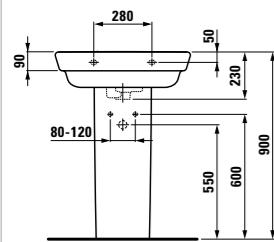
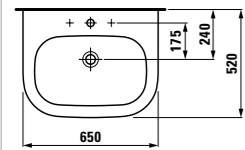

.104 .108 .109



81268.5 ○/●/●●●  
**Washbasin**  
 Waschtisch  
 Lavabo  
 Lavabo

81968.1  
**Siphon cover, ceramic**  
 Siphonverkleidung, Keramik  
 Cache-siphon, céramique  
 Semicolonna, ceramica

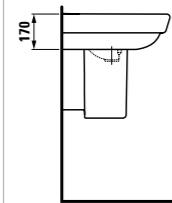
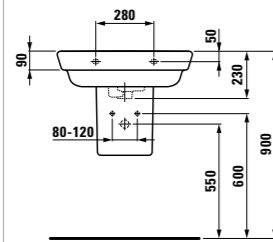
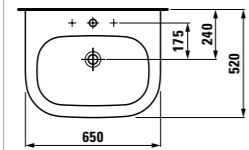

.104 .108 .109



81268.6 ○/●/●●●  
**Countertop washbasin, cuttable**  
 Waschtisch unterbaufähig, schneidbar  
 Lavabo à poser sur meuble, à couper  
 Lavabo consolle, tagliabile su misura

87868.3/4  
**Side cover left/right, ceramic**  
 Seitliche Abdeckplatte links/rechts, Keramik  
 Plaque latérale gauche/droite, céramique  
 Terminale sinistro/destro, ceramica

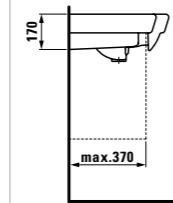
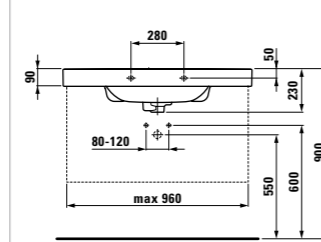
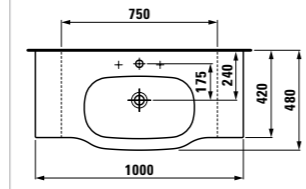

.104 .108 .109 .135 .136 .147  
 .149 .150 .151 .159



81268.6 ○/●/●●●  
**Countertop washbasin, cuttable**  
 Waschtisch unterbaufähig, schneidbar  
 Lavabo à poser sur meuble, à couper  
 Lavabo consolle, tagliabile su misura

81968.0  
**Pedestal, ceramic**  
 Säule, Keramik  
 Colonne, céramique  
 Colonna, ceramica

87868.3/4  
**Side cover left/right, ceramic**  
 Seitliche Abdeckplatte links/rechts, Keramik  
 Plaque latérale gauche/droite, céramique  
 Terminale sinistro/destro, ceramica

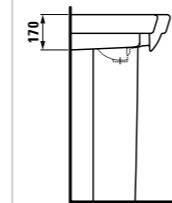
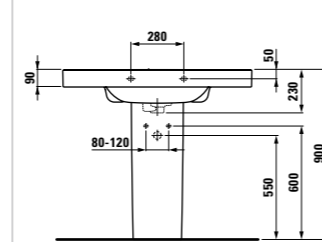
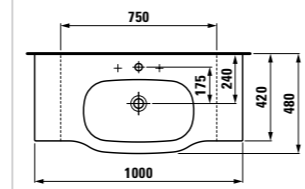

.104 .108 .109 .135 .136 .147  
 .149 .150 .151 .159

# Lb3 by LAUFEN



81268.6 ○/●/●●●  
**Countertop washbasin, cuttable**  
 Waschtisch unterbaufähig, schneidbar  
 Lavabo à poser sur meuble, à couper  
 Lavabo consolle, tagliabile su misura

81968.1  
**Siphon cover, ceramic**  
 Siphonverkleidung, Keramik  
 Cache-siphon, céramique  
 Semicolonna, ceramica

87868.3/4  
**Side cover left/right, ceramic**  
 Seitliche Abdeckplatte links/rechts, Keramik  
 Plaque latérale gauche/droite, céramique  
 Terminale sinistro/destro, ceramica

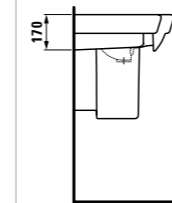
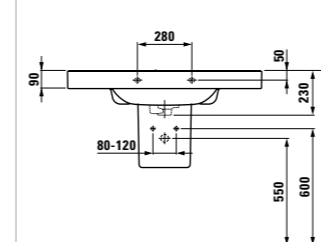
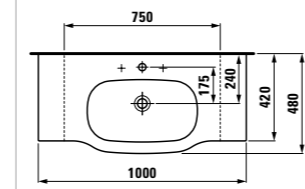

.104 .108 .109 .135 .136 .147  
 .149 .150 .151 .159

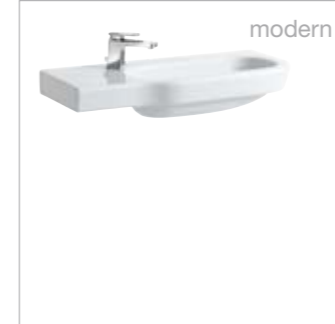

81368.1 ○/●  
**Washbasin**  
 Waschtisch  
 Lavabo  
 Lavabo

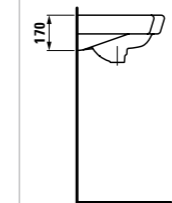
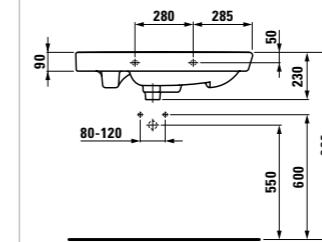
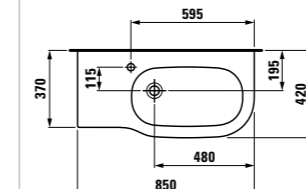

.105 .109

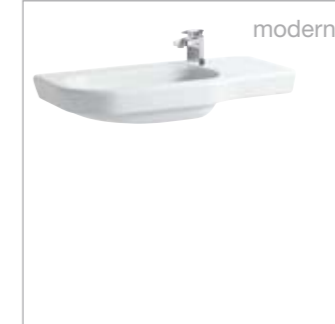

81368.2 ○/●  
**Washbasin**  
 Waschtisch  
 Lavabo  
 Lavabo

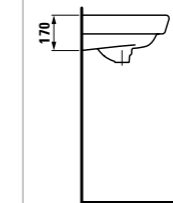
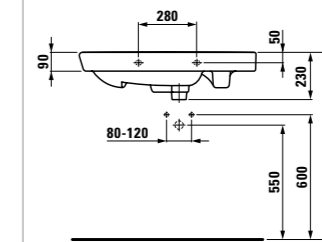
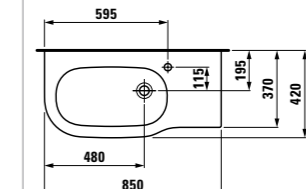

.106 .109



81368.3 ○/●  
**Washbasin, cuttable**  
 Waschtisch, schneidbar  
 Lavabo, à couper  
 Lavabo, tagliabile su misura

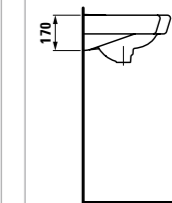
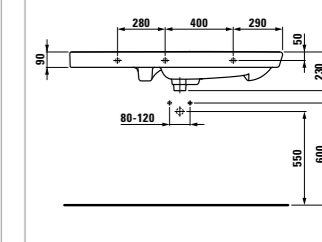
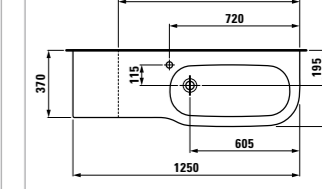

.105 .109 .135 .159

Ceramic colours / Keramikfarben / Couleurs céramique /  
 Colori della ceramica

.000 White / Weiss / Blanc / Bianco  
 .400 White / Weiss / Blanc / Bianco LCC (Laufen Clean Coat)

.049 Pergamon / Pergamon / Pergamon / Pergamon



modern

81368.4  
**Washbasin, cuttable**  
 Waschtisch, schneidbar  
 Lavabo, à couper  
 Lavabo, tagliabile su misura

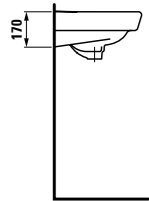
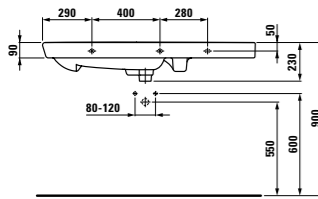
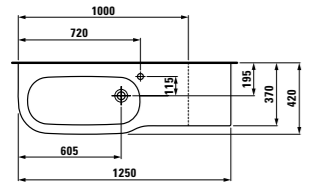

.106 .109 .135 .159

**Types of washbasins / Ausführungen Waschtische / Exécutions lavabos / Modelli lavabi**

- |                                                                                                                                                                                                                                                                                                                                                                                                                                                                                                                                                                                                                          |                                                                                                                                                                                                                                                                                                                                                                                                                                                                                                                                                                                                                                                                                                                                                                                                                         |                                                                                                                                                                                                                                                                                                                                                                                                                                                                                                                                                                                              |
|--------------------------------------------------------------------------------------------------------------------------------------------------------------------------------------------------------------------------------------------------------------------------------------------------------------------------------------------------------------------------------------------------------------------------------------------------------------------------------------------------------------------------------------------------------------------------------------------------------------------------|-------------------------------------------------------------------------------------------------------------------------------------------------------------------------------------------------------------------------------------------------------------------------------------------------------------------------------------------------------------------------------------------------------------------------------------------------------------------------------------------------------------------------------------------------------------------------------------------------------------------------------------------------------------------------------------------------------------------------------------------------------------------------------------------------------------------------|----------------------------------------------------------------------------------------------------------------------------------------------------------------------------------------------------------------------------------------------------------------------------------------------------------------------------------------------------------------------------------------------------------------------------------------------------------------------------------------------------------------------------------------------------------------------------------------------|
| <p>.104 <b>1 tap hole</b><br/>1 Hahnloch<br/>1 trou pour la robinetterie<br/>1 foro per la rubinetteria</p> <p>.105 <b>1 tap hole left</b><br/>1 Hahnloch links<br/>1 trou pour la robinetterie à gauche<br/>1 foro per la rubinetteria a sinistra</p> <p>.106 <b>1 tap hole right</b><br/>1 Hahnloch rechts<br/>1 trou pour la robinetterie à droite<br/>1 foro per la rubinetteria a destra</p> <p>.108 <b>3 tap holes</b><br/>3 Hahnlöcher<br/>3 trous pour la robinetterie<br/>3 fori per la rubinetteria</p> <p>.109 <b>Without tap hole</b><br/>Ohne Hahnloch<br/>Non percé<br/>Senza foro per la rubinetteria</p> | <p>.135 <b>1 tap hole, cut one-sided</b><br/>1 Hahnloch, einseitig geschnitten<br/>1 trou pour la robinetterie, coupé sur 1 côté<br/>1 foro per la rubinetteria, tagliato su un lato</p> <p>.136 <b>3 tap holes US/CAN, distance 8 inches</b><br/>3 Hahnlöcher US/CAN, Abstand 8 Zoll<br/>3 trous pour la robinetterie US/CAN, distance 8 pouces<br/>3 fori per la rubinetteria US/CAN, distanza 8 pollici</p> <p>.147 <b>1 tap hole, cut on both sides</b><br/>1 Hahnloch, beidseitig geschnitten<br/>1 trou pour la robinetterie, coupé sur 2 côtés<br/>1 foro per la rubinetteria, tagliato su entrambi i lati</p> <p>.149 <b>Without tap hole, cut on both sides</b><br/>Ohne Hahnloch, beidseitig geschnitten<br/>Non percé, coupé sur 2 côtés<br/>Senza foro per la rubinetteria, tagliato su entrambi i lati</p> | <p>.150 <b>3 tap holes, cut on one side</b><br/>3 Hahnlöcher, einseitig geschnitten<br/>3 trous pour la robinetterie, coupé sur 1 côté<br/>3 fori per la rubinetteria, tagliato su un lato</p> <p>.151 <b>3 tap holes, cut on both sides</b><br/>3 Hahnlöcher, beidseitig geschnitten<br/>3 trous pour la robinetterie, coupé sur 2 côtés<br/>3 fori per la rubinetteria, tagliato su entrambi i lati</p> <p>.159 <b>Without tap hole, cut one side</b><br/>Ohne Hahnloch, einseitig geschnitten<br/>Non percé, coupé sur 1 côté<br/>Senza foro per la rubinetteria, tagliato su un lato</p> |
|--------------------------------------------------------------------------------------------------------------------------------------------------------------------------------------------------------------------------------------------------------------------------------------------------------------------------------------------------------------------------------------------------------------------------------------------------------------------------------------------------------------------------------------------------------------------------------------------------------------------------|-------------------------------------------------------------------------------------------------------------------------------------------------------------------------------------------------------------------------------------------------------------------------------------------------------------------------------------------------------------------------------------------------------------------------------------------------------------------------------------------------------------------------------------------------------------------------------------------------------------------------------------------------------------------------------------------------------------------------------------------------------------------------------------------------------------------------|----------------------------------------------------------------------------------------------------------------------------------------------------------------------------------------------------------------------------------------------------------------------------------------------------------------------------------------------------------------------------------------------------------------------------------------------------------------------------------------------------------------------------------------------------------------------------------------------|

**Types of WC, bidet / Ausführungen WC, Bidet / Exécutions wc, bidet / Modelli vasi, bidet**

- |                                                                                                                                                                                                                                                                                                                                                                                                                                                                                                                                                                                                                                                                        |                                                                                                                                                                                                                                                                                                                                                                                                                                                                                                                                                                                                                                                                                                                                                                                                                             |                                                                                                                                                                                                                                                                                                                                                                                                                                                                                                                                                                                                                                                                                              |
|------------------------------------------------------------------------------------------------------------------------------------------------------------------------------------------------------------------------------------------------------------------------------------------------------------------------------------------------------------------------------------------------------------------------------------------------------------------------------------------------------------------------------------------------------------------------------------------------------------------------------------------------------------------------|-----------------------------------------------------------------------------------------------------------------------------------------------------------------------------------------------------------------------------------------------------------------------------------------------------------------------------------------------------------------------------------------------------------------------------------------------------------------------------------------------------------------------------------------------------------------------------------------------------------------------------------------------------------------------------------------------------------------------------------------------------------------------------------------------------------------------------|----------------------------------------------------------------------------------------------------------------------------------------------------------------------------------------------------------------------------------------------------------------------------------------------------------------------------------------------------------------------------------------------------------------------------------------------------------------------------------------------------------------------------------------------------------------------------------------------------------------------------------------------------------------------------------------------|
| <p>.231 <b>With 2 fixing holes, with lateral mounting holes for water inlet</b><br/>Mit 2 Befestigungslöchern, mit seitlichen Öffnungen für Wasseranschluss<br/>Avec 2 trous de fixation, avec trous latéraux pour le raccordement de l'eau<br/>Con 2 fori di montaggio, con fori laterali per l'attacco dell'acqua</p> <p>.250 <b>With fixing holes, without holes at sides, US/CAN version, cUPC certified</b><br/>Mit Montagelöchern, ohne seitliche Löcher, US/CAN Version, cUPC zertifiziert<br/>Avec trous de fixation, sans trous latéraux, version US/CAN, certifié cUPC<br/>Con fori di montaggio, senza fori laterali, versione US/CAN, certificato cUPC</p> | <p>.251 <b>With 2 fixing holes, with lateral mounting holes for water inlet, US/CAN version, cUPC certified</b><br/>Mit 2 Befestigungslöchern, mit seitlichen Öffnungen für Wasseranschluss, US/CAN Version, cUPC zertifiziert<br/>Avec 2 trous de fixation, avec trous latéraux pour le raccordement de l'eau, version US/CAN, certifié cUPC<br/>Con 2 fori di montaggio, con fori laterali per l'attacco dell'acqua, versione US/CAN, certificato cUPC</p> <p>.302 <b>With 1 tap hole in centre, without mounting hole at sides for water inlet</b><br/>Mit 1 Hahnloch mittig, ohne seitliches Loch für Wasseranschluss<br/>Avec 1 trou pour la robinetterie au milieu, sans trou sur le côté pour le raccordement de l'eau<br/>Con 1 foro centrale per la rubinetteria, senza foro laterale per l'attacco dell'acqua</p> | <p>.304 <b>With 1 tap hole in the middle, with mounting hole at sides for water inlet</b><br/>Mit 1 Hahnloch mittig, mit seitlichem Loch für Wasseranschluss<br/>Avec 1 trou pour la robinetterie au milieu, avec trou sur le côté pour le raccordement de l'eau<br/>Con 1 foro centrale per la rubinetteria, con foro laterale per l'attacco dell'acqua</p> <p>.308 <b>With 3 tap holes, without mounting hole at sides for water inlet</b><br/>Mit 3 Hahnlöchern, ohne seitliches Loch für Wasseranschluss<br/>Avec 3 trous pour la robinetterie, sans trou sur le côté pour le raccordement de l'eau<br/>Con 3 fori per la rubinetteria, senza foro laterale per l'attacco dell'acqua</p> |
|------------------------------------------------------------------------------------------------------------------------------------------------------------------------------------------------------------------------------------------------------------------------------------------------------------------------------------------------------------------------------------------------------------------------------------------------------------------------------------------------------------------------------------------------------------------------------------------------------------------------------------------------------------------------|-----------------------------------------------------------------------------------------------------------------------------------------------------------------------------------------------------------------------------------------------------------------------------------------------------------------------------------------------------------------------------------------------------------------------------------------------------------------------------------------------------------------------------------------------------------------------------------------------------------------------------------------------------------------------------------------------------------------------------------------------------------------------------------------------------------------------------|----------------------------------------------------------------------------------------------------------------------------------------------------------------------------------------------------------------------------------------------------------------------------------------------------------------------------------------------------------------------------------------------------------------------------------------------------------------------------------------------------------------------------------------------------------------------------------------------------------------------------------------------------------------------------------------------|



classic

81068.2  
**Small washbasin**  
 Handwaschbecken  
 Lave-mains  
 Lavamani

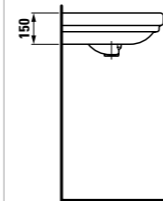
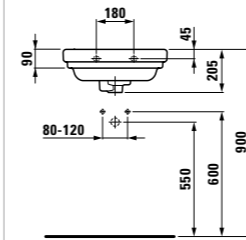
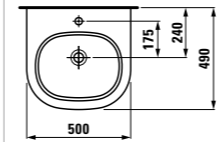

.104 .109



classic

81068.4  
**Washbasin**  
 Waschtisch  
 Lavabo  
 Lavabo

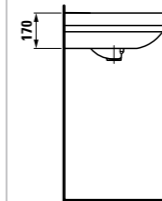
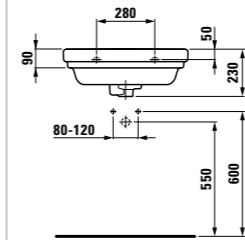
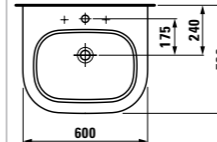

.104 .108 .109 .136



classic

81068.4  
**Washbasin**  
 Waschtisch  
 Lavabo  
 Lavabo

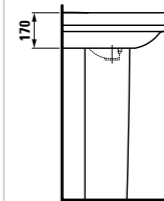
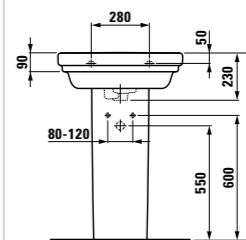
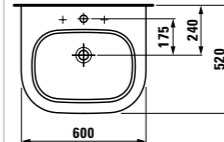

.104 .108 .109 .136



classic

81068.4  
**Washbasin**  
 Waschtisch  
 Lavabo  
 Lavabo

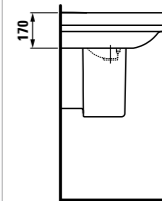
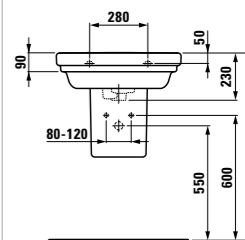
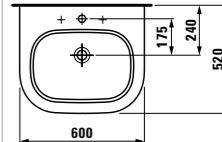

.104 .108 .109 .136

**Ceramic colours / Keramikfarben / Couleurs céramique / Colori della ceramica**

- .000 White / Weiss / Blanc / Bianco
- .400 White / Weiss / Blanc / Bianco LCC (Laufen Clean Coat)
- .049 Pergamon / Pergamon / Pergamon / Pergamon

# Lb3 by LAUFEN

classic



81068.5 

**Washbasin**  
Waschtisch  
Lavabo  
Lavabo

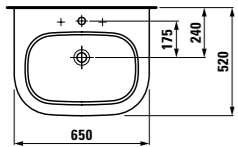
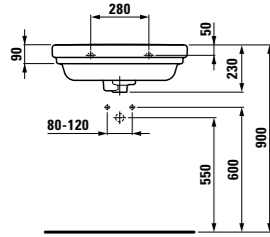
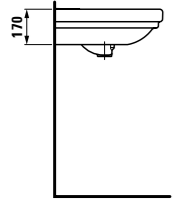
.104 .108 .109

classic



81068.5 

**Washbasin**  
Waschtisch  
Lavabo  
Lavabo

81968.0  
**Pedestal, ceramic**  
Säule, Keramik  
Colonne, céramique  
Colonna, ceramica

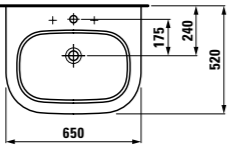
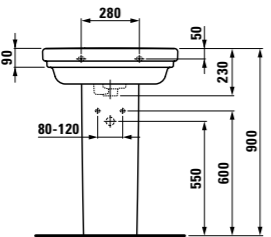
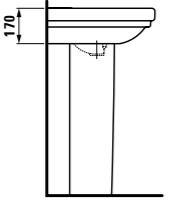
.104 .108 .109

classic



81068.5 

**Washbasin**  
Waschtisch  
Lavabo  
Lavabo

81968.1  
**Siphon cover, ceramic**  
Siphonverkleidung, Keramik  
Cache-siphon, céramique  
Semicolonna, ceramica

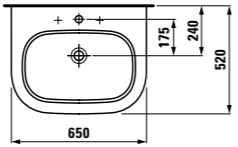
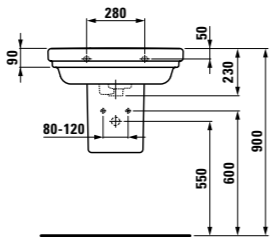
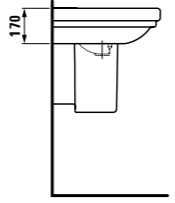
.104 .108 .109

classic



81068.6 

**Countertop washbasin, cuttable**  
Waschtisch unterbaufähig, schneidbar  
Lavabo à poser sur meuble, à couper  
Lavabo consolle, tagliabile su misura

87868.1/2  
**Side cover left/right, ceramic**  
Seitliche Abdeckplatte links/rechts, Keramik  
Plaque latérale gauche/droite, céramique  
Terminale sinistro/destro, ceramica

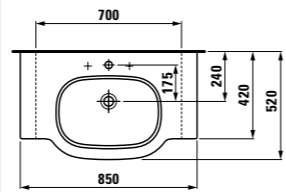
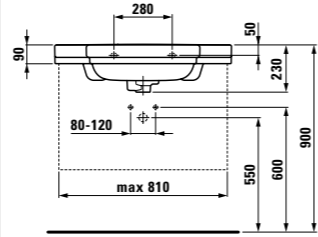
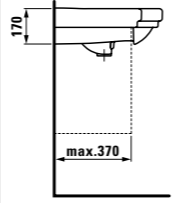



.104 .108 .109 .135 .136 .147  
.149 .150 .151 .159

# Lb3 by LAUFEN

classic



81068.6 

**Countertop washbasin, cuttable**  
Waschtisch unterbaufähig, schneidbar  
Lavabo à poser sur meuble, à couper  
Lavabo consolle, tagliabile su misura

81968.0  
**Pedestal, ceramic**  
Säule, Keramik  
Colonne, céramique  
Colonna, ceramica

87868.1/2  
**Side cover left/right, ceramic**  
Seitliche Abdeckplatte links/rechts, Keramik  
Plaque latérale gauche/droite, céramique  
Terminale sinistro/destro, ceramica

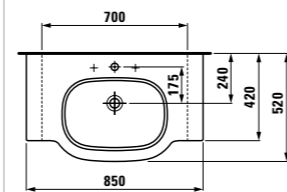
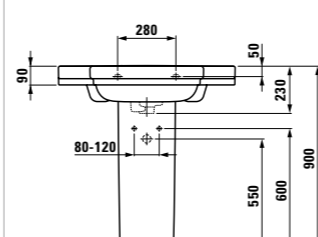
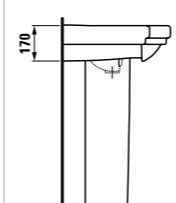
.104 .108 .109 .135 .136 .147  
.149 .150 .151 .159

classic



81068.6 

**Countertop washbasin, cuttable**  
Waschtisch unterbaufähig, schneidbar  
Lavabo à poser sur meuble, à couper  
Lavabo consolle, tagliabile su misura

81968.1  
**Siphon cover, ceramic**  
Siphonverkleidung, Keramik  
Cache-siphon, céramique  
Semicolonna, ceramica

87868.1/2  
**Side cover left/right, ceramic**  
Seitliche Abdeckplatte links/rechts, Keramik  
Plaque latérale gauche/droite, céramique  
Terminale sinistro/destro, ceramica

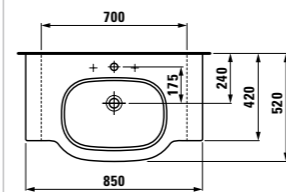
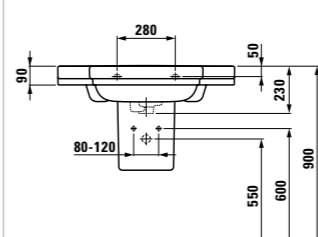
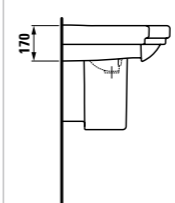
.104 .108 .109 .135 .136 .147  
.149 .150 .151 .159

classic



81068.8 

**Countertop washbasin, cuttable**  
Waschtisch unterbaufähig, schneidbar  
Lavabo à poser sur meuble, à couper  
Lavabo consolle, tagliabile su misura

87868.1/2  
**Side cover left/right, ceramic**  
Seitliche Abdeckplatte links/rechts, Keramik  
Plaque latérale gauche/droite, céramique  
Terminale sinistro/destro, ceramica

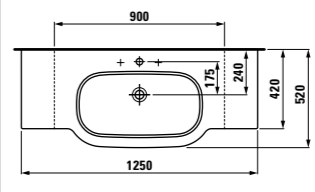
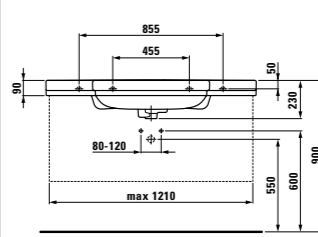
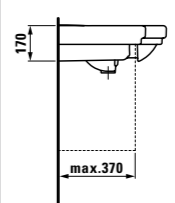
.104 .108 .109 .135 .136 .147  
.149 .150 .151 .159

classic



81068.8 

**Countertop washbasin, cuttable**  
Waschtisch unterbaufähig, schneidbar  
Lavabo à poser sur meuble, à couper  
Lavabo consolle, tagliabile su misura

81968.0  
**Pedestal, ceramic**  
Säule, Keramik  
Colonne, céramique  
Colonna, ceramica

87868.1/2  
**Side cover left/right, ceramic**  
Seitliche Abdeckplatte links/rechts, Keramik  
Plaque latérale gauche/droite, céramique  
Terminale sinistro/destro, ceramica

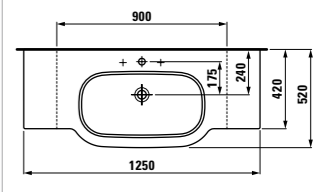
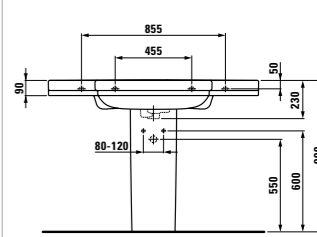
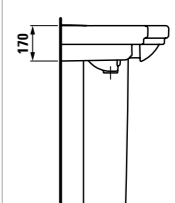
.104 .108 .109 .135 .136 .147  
.149 .150 .151 .159

Ceramic colours / Keramikfarben / Couleurs céramique / Colori della ceramica

 .000 White / Weiss / Blanc / Bianco  
 .400 White / Weiss / Blanc / Bianco LCC (Laufen Clean Coat)

 .049 Pergamon / Pergamon / Pergamon / Pergamon



# Lb3 by LAUFEN



classic

81068.8   
**Countertop washbasin, cuttable**  
 Waschtisch unterbaufähig, schneidbar  
 Lavabo à poser sur meuble, à couper  
 Lavabo consolle, tagliabile su misura

81968.1  
**Siphon cover, ceramic**  
 Siphonverkleidung, Keramik  
 Cache-siphon, céramique  
 Semicolonna, ceramica

87868.1/.2  
**Side cover left/right, ceramic**  
 Seitliche Abdeckplatte links/rechts,  
 Keramik  
 Plaque latérale gauche/droite,  
 céramique  
 Terminale sinistro/destro, ceramica

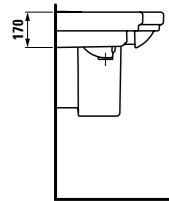
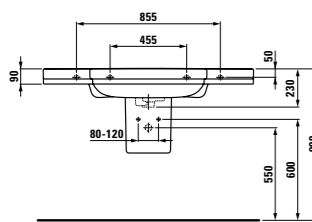
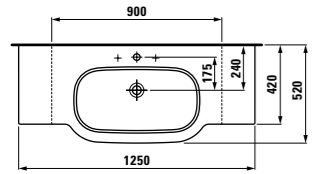

.104 .108 .109 .135 .136 .147  
 .149 .150 .151 .159



classic

81168.2   
**Drop-in washbasin**  
 Einbauwaschtisch von oben  
 Lavabo à encastrer par-dessus  
 Lavabo da incasso soprapiano

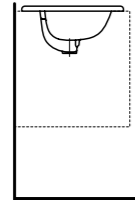
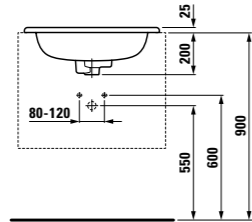
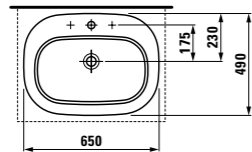

.104 .108 .109 .136



design

81468.1   
**Countertop washbasin**  
 Waschtisch unterbaufähig  
 Lavabo à poser sur meuble  
 Lavabo consolle

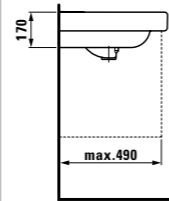
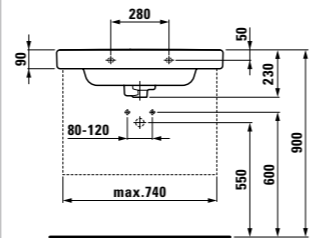
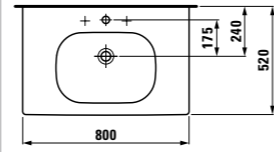

.104 .108 .109 .136

# Lb3 by LAUFEN



design

81468.1   
**Countertop washbasin**  
 Waschtisch unterbaufähig  
 Lavabo à poser sur meuble  
 Lavabo consolle

81968.0  
**Pedestal, ceramic**  
 Säule, Keramik  
 Colonne, céramique  
 Colonna, ceramica

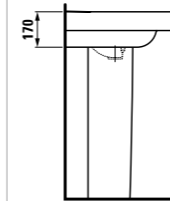
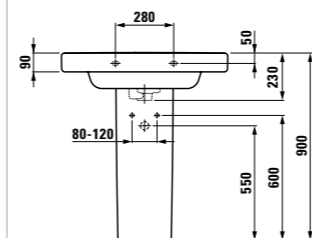
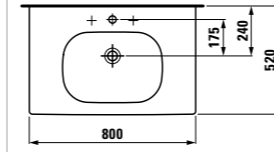

.104 .108 .109 .136



design

81468.1   
**Countertop washbasin**  
 Waschtisch unterbaufähig  
 Lavabo à poser sur meuble  
 Lavabo consolle

81968.1  
**Siphon cover, ceramic**  
 Siphonverkleidung, Keramik  
 Cache-siphon, céramique  
 Semicolonna, ceramica

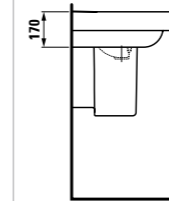
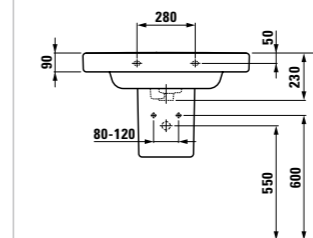
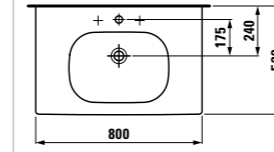

.104 .108 .109 .136



design

81468.2   
**Countertop washbasin**  
 Waschtisch unterbaufähig  
 Lavabo à poser sur meuble  
 Lavabo consolle

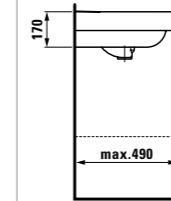
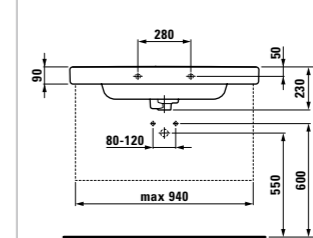
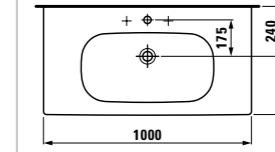

.104 .108 .109 .136



design

81468.2   
**Countertop washbasin**  
 Waschtisch unterbaufähig  
 Lavabo à poser sur meuble  
 Lavabo consolle

81968.0  
**Pedestal, ceramic**  
 Säule, Keramik  
 Colonne, céramique  
 Colonna, ceramica

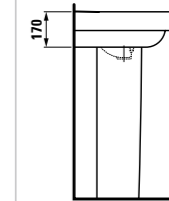
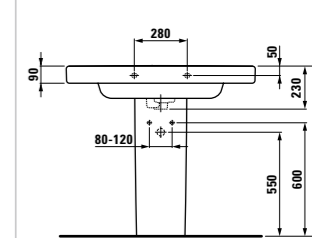
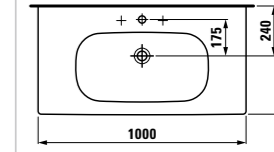

.104 .108 .109 .136

**Ceramic colours / Keramikfarben / Couleurs céramique / Colori della ceramica**

.000 White / Weiss / Blanc / Bianco  
 .400 White / Weiss / Blanc / Bianco LCC (Laufen Clean Coat)

.049 Pergamon / Pergamon / Pergamon / Pergamon

# Lb3 by LAUFEN



§1468.2   
**Countertop washbasin**  
 Waschtisch unterbaufähig  
 Lavabo à poser sur meuble  
 Lavabo consolle

§1968.1  
**Siphon cover, ceramic**  
 Siphonverkleidung, Keramik  
 Cache-siphon, céramique  
 Semicolonna, ceramica

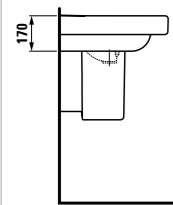
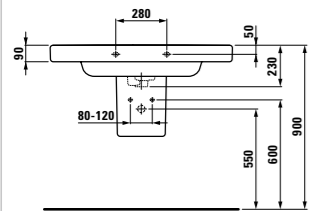
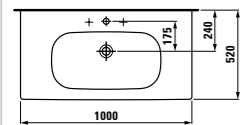

.104 .108 .109 .136



§1468.3   
**Double countertop washbasin**  
 Doppelwaschtisch unterbaufähig  
 Lavabo double à poser sur meuble  
 Lavabo doppio consolle

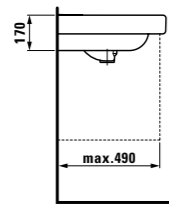
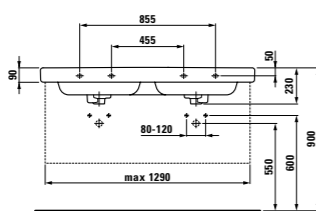
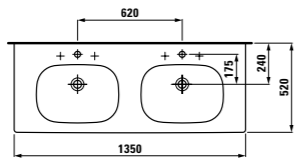

.104 .108 .109 .136



§1468.3   
**Double countertop washbasin**  
 Doppelwaschtisch unterbaufähig  
 Lavabo double à poser sur meuble  
 Lavabo doppio consolle

§1968.0  
**Pedestal, ceramic**  
 Säule, Keramik  
 Colonne, céramique  
 Colonna, ceramica

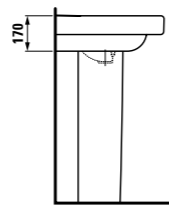
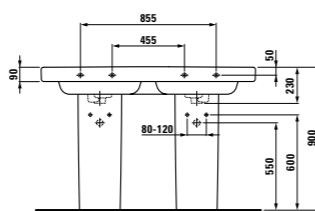
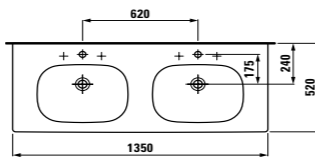

.104 .108 .109 .136

**Ceramic colours / Keramikfarben / Couleurs céramique / Colori della ceramica**

.000 White / Weiss / Blanc / Bianco  
 .400 White / Weiss / Blanc / Bianco LCC (Laufen Clean Coat)

.049 Pergamon / Pergamon / Pergamon / Pergamon



§1468.3   
**Double countertop washbasin**  
 Doppelwaschtisch unterbaufähig  
 Lavabo double à poser sur meuble  
 Lavabo doppio consolle

§1968.1  
**Siphon cover, ceramic**  
 Siphonverkleidung, Keramik  
 Cache-siphon, céramique  
 Semicolonna, ceramica

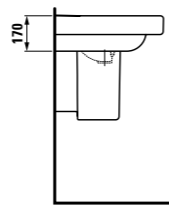
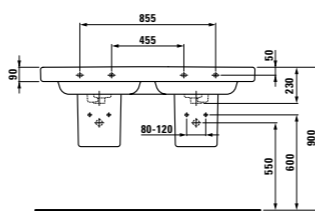
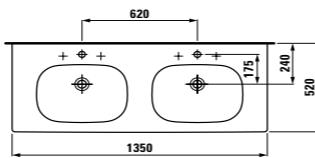

.104 .108 .109 .136

# Lb3 by LAUFEN



§2468.4  
**Floorstanding WC combination, washdown, horizontal/vertical outlet, Vario**  
 Stand-WC Kombination, Tiefspüler, Abgang waagrecht/senkrecht, Vario  
 Installation de WC au sol, à chasse directe, sortie horizontale/verticale, évacuation Vario  
 Vaso monoblocco a pavimento, a cacciata, scarico a parete/a pavimento, scarico Vario

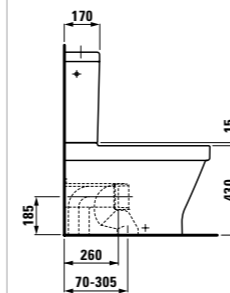
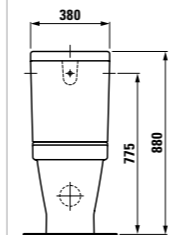
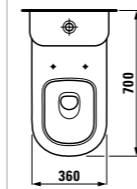

.231 .251



§2168.4  
**Floorstanding WC, washdown, horizontal/vertical outlet, Vario**  
 Stand-WC, Tiefspüler, Abgang waagrecht/senkrecht, Vario  
 WC au sol, à chasse directe, sortie horizontale/verticale, évacuation Vario  
 Vaso monoblocco a pavimento, a cacciata, scarico a parete/a pavimento, scarico Vario

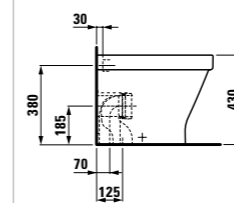
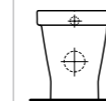
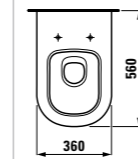

.250



§2068.0  
**Wallhung WC, washdown**  
 Wand-WC, Tiefspüler  
 WC suspendu, à chasse directe  
 Vaso sospeso, a cacciata

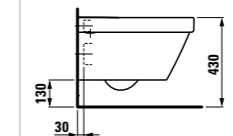
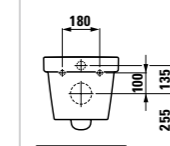
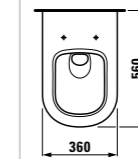

.250



§2868.0  
**Cistern, water connection on one side (left or right) and at the back in the centre**  
 Spülkasten, Wasseranschluss seitlich (links oder rechts) und hinten Mitte  
 Réservoir, raccordement de l'eau latéral (gauche ou droite) et milieu arrière  
 Cassetta di sciacquo, attacco dell'acqua laterale (a sinistra o a destra) e centrale posteriore

.278

§2868.2  
**Cistern, water connection on one side (left or right)**  
 Spülkasten, Wasseranschluss seitlich (links oder rechts)  
 Réservoir, raccordement de l'eau latéral (gauche ou droite)  
 Cassetta di sciacquo, attacco dell'acqua laterale (a sinistra o a destra)

.278

§2868.3  
**Cistern, water connection at the bottom left**  
 Spülkasten, Wasseranschluss unten links  
 Réservoir, raccordement de l'eau en bas à gauche  
 Cassetta di sciacquo, attacco dell'acqua dal basso a sinistra

.261 .277 .291

§2868.5  
**Cistern, water connection at the bottom right**  
 Spülkasten, Wasseranschluss unten rechts  
 Réservoir, raccordement de l'eau en bas à droite  
 Cassetta di sciacquo, attacco dell'acqua dal basso a destra

.286

# Lb3 by LAUFEN

modern/design



89568.2  
**Removable WC seat and cover, with anti-bacterial effect**  
WC-Sitz mit Deckel, abnehmbar, mit antibakterieller Wirkung  
Siège avec abattant, amovible, avec effet antibactérien  
Sedile copri water, estraibile, con effetto antibatterico

89568.3  
**Removable WC seat and cover, with hydraulic lowering system and anti-bacterial effect**  
WC-Sitz mit Deckel, abnehmbar, mit hydraulischer Absenkautomatik und antibakterieller Wirkung  
Siège avec abattant, amovible, avec abaissement automatique hydraulique et effet antibactérien  
Sedile copri water, estraibile, con sistema di abbassamento idraulico e con effetto antibatterico

classic



89568.0  
**Removable WC seat and cover, with anti-bacterial effect**  
WC-Sitz mit Deckel, abnehmbar, mit antibakterieller Wirkung  
Siège avec abattant, amovible, avec effet antibactérien  
Sedile copri water, estraibile, con effetto antibatterico

89568.1  
**Removable WC seat and cover, with hydraulic lowering system and anti-bacterial effect**  
WC-Sitz mit Deckel, abnehmbar, mit hydraulischer Absenkautomatik und antibakterieller Wirkung  
Siège avec abattant, amovible, avec abaissement automatique hydraulique et effet antibactérien  
Sedile copri water, estraibile, con sistema di abbassamento idraulico e con effetto antibatterico



83268.1  
**Floorstanding bidet**  
Standbidet  
Bidet au sol  
Bidet a pavimento

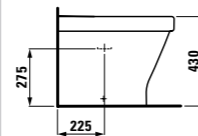
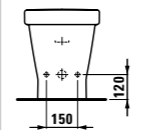
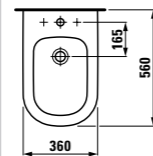

.302 .308



83068.2  
**Wallhung bidet, with concealed water inlet**  
Wandbidet, Wasserzulauf verdeckt  
Bidet suspendu, avec alimentation d'eau cachée  
Bidet sospeso, con alimentazione acqua nascosta

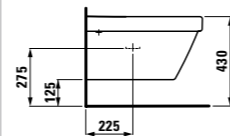
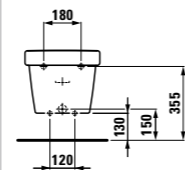
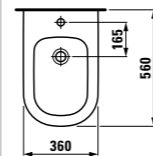

.302

Ceramic colours / Keramikfarben / Couleurs céramique / Colori della ceramica

.000 White / Weiss / Blanc / Bianco  
.400 White / Weiss / Blanc / Bianco LCC (Laufen Clean Coat)

.049 Pergamon / Pergamon / Pergamon / Pergamon

Seat and cover colours / Farben Sitz und Deckel / Couleurs du siège avec abattant / Colori del sedile copri water

.300 White anti-bacterial / Weiss antibakteriell / Blanc antibactérien / Bianco antibatterico

.349 Pergamon anti-bacterial / Pergamon antibakteriell / Pergamon antibactérien / Pergamon antibatterico

# Lb3 by LAUFEN



23068.0  
**Bath tub, drop-in version, sanitary acrylic, with outlet cover, 1800x800 mm**  
Badewanne, Einbauversion, Sanitäracryl, mit Ablaufabdeckung, 1800x800 mm  
Baignoire, version à encastrer, acrylique sanitaire, avec cache-écoulement, 1800x800 mm  
Vasca, versione da incasso, acrilico sanitario, con copri-piletta, 1800x800 mm

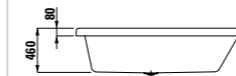
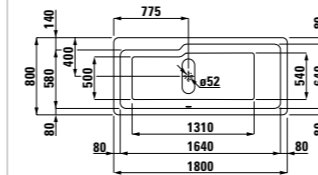

23068.1  
**Bath tub, free-standing, with frame, sanitary acrylic, with outlet cover, 1800x800 mm, also available with whirlsystem**  
Badewanne, freistehend, mit Fussgestell, Sanitäracryl, mit Ablaufabdeckung, 1800x800 mm, auch mit Whirlsystem erhältlich  
Baignoire, indépendante, avec piètement, acrylique sanitaire, avec cache-écoulement, 1800x800 mm, aussi disponible avec système balnéo  
Vasca, versione a centro stanza, con base, in acrilico sanitario, con copri-piletta, 1800x800 mm, disponibile anche con sistema idromassaggio

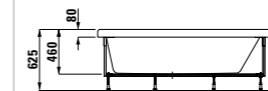
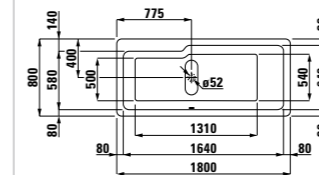

29868.2.xxx.000.1  
**Wooden panel set (4 sides) for the bathtub 23068.1**  
Holzverkleidung (4 Seiten) für Badewanne 23068.1  
Set de tabliers en bois (4 côtés) pour la baignoire 23068.1  
Set di pannelli in legno (4 lati) per la vasca 23068.1

29868.2.xxx.568.1  
**Wooden panel set (4 sides) for the bathtub 23068.1 with whirlsystem**  
Holzverkleidung (4 Seiten) für Badewanne 23068.1 mit Whirlsystem  
Set de tabliers en bois (4 côtés) pour la baignoire 23068.1 avec balnéo  
Set di pannelli in legno (4 lati) per la vasca 23068.1 con sistema idromassaggio



23268.0  
**Bath tub for right-hand corner, drop-in version, sanitary acrylic, with outlet cover, 1800x800 mm**  
Badewanne für die rechte Ecke, Einbauversion, Sanitäracryl, mit Ablaufabdeckung, 1800x800 mm  
Baignoire d'angle à droite, version à encastrer, acrylique sanitaire, avec cache-écoulement, 1800x800 mm  
Vasca per l'angolo destro, versione da incasso, acrilico sanitario, con copri-piletta, 1800x800 mm

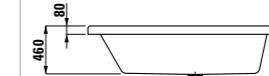
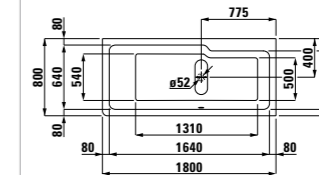

23268.1  
**Bath tub for right-hand corner, with frame, sanitary acrylic, with outlet cover, 1800x800 mm, also available with whirlsystem**  
Badewanne für die rechte Ecke, mit Fussgestell, Sanitäracryl, mit Ablaufabdeckung, 1800x800 mm, auch mit Whirlsystem erhältlich  
Baignoire d'angle à droite, avec piètement, acrylique sanitaire, avec cache-écoulement, 1800x800 mm, aussi disponible avec système balnéo  
Vasca per l'angolo destro, con base, in acrilico sanitario, con copri-piletta, 1800x800 mm, disponibile anche con sistema idromassaggio

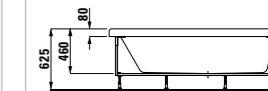
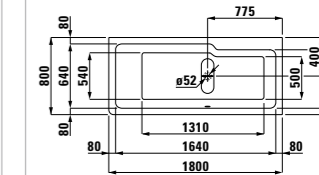

29868.5.xxx.000.1  
**Wooden panel set (2 sides) for the bathtub 23268.1**  
Holzverkleidung (2 Seiten) für Badewanne 23268.1  
Set de tabliers en bois (2 côtés) pour la baignoire 23268.1  
Set di pannelli in legno (2 lati) per la vasca 23268.1

29868.5.xxx.568.1  
**Wooden panel set (2 sides) for the bathtub 23268.1 with whirlsystem**  
Holzverkleidung (2 Seiten) für Badewanne 23268.1 mit Whirlsystem  
Set de tabliers en bois (2 côtés) pour la baignoire 23268.1 avec balnéo  
Set di pannelli in legno (2 lati) per la vasca 23268.1 con sistema idromassaggio



**23368.0**  
**Bathtub for left-hand corner, drop-in version, sanitary acrylic, with outlet cover, 1800x800 mm**  
 Badewanne für die linke Ecke, Einbauversion, Sanitäracryl, mit Ablaufabdeckung, 1800x800 mm  
 Baignoire d'angle à gauche, version à encastrer, acrylique sanitaire, avec cache-écoulement, 1800x800 mm  
 Vasca per l'angolo sinistro, versione da incasso, acrilico sanitario, con copri-piletta, 1800x800 mm

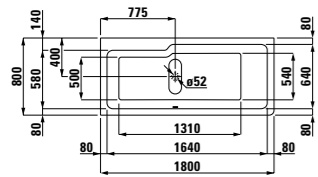

**23368.1**  
**Bathtub for left-hand corner, with frame, sanitary acrylic, with outlet cover, 1800x800 mm, also available with whirlsystem**  
 Badewanne für die linke Ecke, mit Fussgestell, Sanitäracryl, mit Ablaufabdeckung, 1800x800 mm, auch mit Whirlsystem erhältlich  
 Baignoire d'angle à gauche, avec piètement, acrylique sanitaire, avec cache-écoulement, 1800x800 mm, aussi disponible avec système balnéo  
 Vasca per l'angolo sinistro, con base, in acrilico sanitario, con copri-piletta, 1800x800 mm, disponibile anche con sistema idromassaggio

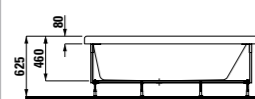
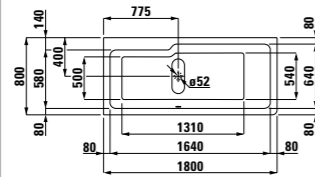

**29868.6.xxx.000.1**  
**Wooden panel set (2 sides) for the bathtub 23368.1**  
 Holzverkleidung (2 Seiten) für Badewanne 23368.1  
 Set de tabliers en bois (2 côtés) pour la baignoire 23368.1  
 Set di pannelli in legno (2 lati) per la vasca 23368.1

**29868.6.xxx.568.1**  
**Wooden panel set (2 sides) for the bathtub 23368.1 with whirlsystem**  
 Holzverkleidung (2 Seiten) für Badewanne 23368.1 mit Whirlsystem  
 Set de tabliers en bois (2 côtés) pour la baignoire 23368.1 avec balnéo  
 Set di pannelli in legno (2 lati) per la vasca 23368.1 con sistema idromassaggio





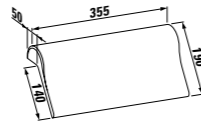

**29468.0**  
**Gel pillow, self adhesive**  
 Gel Kissen, selbsthaftend  
 Coussin gel, autoadhérent  
 Cuscino in gel, autoadesivo

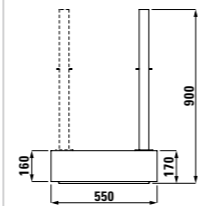
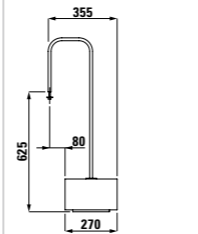

**29468.1**  
**Easy entry step, wood with chrome handle left/right**  
 Einstiegshilfe aus Holz, mit Relling verchromt links/rechts  
 Marchepied en bois, avec poignée chromée gauche/droite  
 Scalino in legno con passamano cromato sinistro/destro



**Bathtub colours / Badewannenfarben / Couleurs baignoires / Colori vasche**

-  **.000 White / Weiss / Blanc / Bianco**
-  **.300 White anti-bacterial / Weiss antibakteriell / Blanc antibactérien / Bianco antibatterico**
-  **.049 Pergamon / Pergamon / Pergamon / Pergamon**
-  **.349 Pergamon anti-bacterial / Pergamon antibakteriell / Pergamon antibactérien / Pergamon antibatterico**

**Gel pillow colour / Gelkissenfarbe / Couleur du coussin gel / Colore cuscino in gel**

-  **.016 Black / Schwarz / Noir / Nero**

**Wooden panel and entry step colours, surface reel wood veneer**  
 Farben Holzschürze und Einstiegshilfe, Oberfläche Echtholzurnier  
 Couleurs du tablier en bois et de la marche d'accès, surface placage en bois  
 Colori di pannelli in legno e scalino, superficie vero legno impiallacciato

-  **.560 White / Weiss / Blanc / Bianco**

-  **.561 Wenge / Wenge / Wengé / Wenge**

-  **.562 Oak / Eiche / Chêne / Rovere**



**21168.2**  
**Shower tray, sanitary acrylic, with outlet cover, 900x900 mm**  
 Duschwanne, Sanitäracryl, mit Ablaufabdeckung, 900x900 mm  
 Receveur de douche, acrylique sanitaire, avec cache-écoulement, 900x900 mm  
 Piatto doccia, in acrilico sanitario, con copri-piletta, 900x900 mm

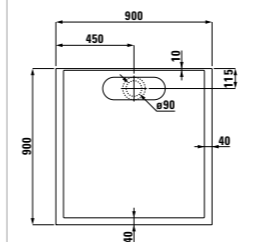

**21168.2.000.680.1**  
**Shower tray, 900x900 mm, with carrier and integrated sealing tape (illbruck based on Poresta® System)**  
 Duschwanne, 900x900 mm, mit Wannenträger und integriertem Dichtband (illbruck based on Poresta® System)  
 Receveur de douche, 900x900 mm, avec support et ruban d'étanchéité intégré (illbruck based on Poresta® System)  
 Piatto doccia, 900x900 mm, con supporto e nastro sigillante integrato (illbruck based on Poresta® System)



**21268.3**  
**Shower tray, sanitary acrylic, with outlet cover, 1200x900 mm**  
 Duschwanne, Sanitäracryl, mit Ablaufabdeckung, 1200x900 mm  
 Receveur de douche, acrylique sanitaire, avec cache-écoulement, 1200x900 mm  
 Piatto doccia, in acrilico sanitario, con copri-piletta, 1200x900 mm

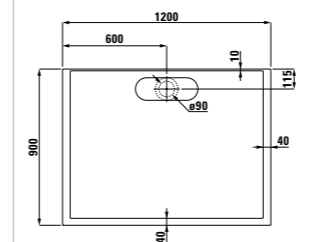

**21268.3.000.680.1**  
**Shower tray, 1200x900 mm, with carrier and integrated sealing tape (illbruck based on Poresta® System)**  
 Duschwanne, 1200x900 mm, mit Wannenträger und integriertem Dichtband (illbruck based on Poresta® System)  
 Receveur de douche, 1200x900 mm, avec support et ruban d'étanchéité intégré (illbruck based on Poresta® System)  
 Piatto doccia, 1200x900 mm, con supporto e nastro sigillante integrato (illbruck based on Poresta® System)

**Bathtub options with whirlsystem / Ausführungen Badewannen mit Whirlsystem / Exécution des baignoires avec balnéo / Versioni delle vasche con sistema idromassaggio**

**Whirlsystems with electronic control / Whirlsysteme mit elektronischer Steuerung / Systèmes balnéo à commande électronique / Sistemi idromassaggio con comandi elettronici**

**000**  
**Without whirlsystem**  
 Ohne Whirlsystem  
 Sans balnéo  
 Senza sistema idromassaggio

**005**  
**Whirlsystem with air and hydromassage and disinfection system**  
 Whirlsystem mit Luft- und Hydromassage und Desinfektionssystem  
 Balnéo avec système d'aéro- et d'hydromassage et système de désinfection  
 Sistema idromassaggio a getto d'aria ed aria/acqua e sistema d'igienizzazione

**050**  
**Whirlsystem with air and hydromassage, water heating and disinfection system**  
 Whirlsystem mit Luft- und Hydromassage, Wasserheizung und Desinfektionssystem  
 Balnéo avec système d'aéro- et d'hydromassage, chauffage de l'eau et système de désinfection  
 Sistema idromassaggio a getto d'aria ed aria/acqua, riscaldatore acqua e sistema d'igienizzazione

**500**  
**Whirlsystem with air and hydromassage, underwater lighting and disinfection system**  
 Whirlsystem mit Luft- und Hydromassage, Unterwasserbeleuchtung und Desinfektionssystem  
 Balnéo avec système d'aéro- et d'hydromassage, éclairage subaquatique et système de désinfection  
 Sistema idromassaggio a getto d'aria ed aria/acqua, faro subacqueo e sistema d'igienizzazione

**055**  
**Whirlsystem with air and hydromassage, water heating, underwater lighting and disinfection system**  
 Whirlsystem mit Luft- und Hydromassage, Wasserheizung, Unterwasserbeleuchtung und Desinfektionssystem  
 Balnéo avec système d'aéro- et d'hydromassage, chauffage de l'eau, éclairage subaquatique et système de désinfection  
 Sistema idromassaggio a getto d'aria ed aria/acqua, riscaldatore acqua, faro subacqueo e sistema d'igienizzazione

**Shower trays for floor level installation / Duschwannen für bodenebenen Einbau / Receveurs de douche pour installation ras du sol / Piatti doccia per installazione a filo pavimento**

**The new extra flat shower trays can be installed exactly at floor level thanks to a factory-fitted carrier with integrated sealing tape (illbruck based on Poresta® System) and are therefore suitable for barrier-free use.**

Die neuen extraflachen Duschwannen lassen sich mittels eines werkseitig montierten Wannenträgers mit integriertem Dichtband (illbruck based on Poresta® System) auch komplett bodeneben und somit barrierefrei einpassen.

Les nouveaux receveurs de douche extraplats peuvent également être installés au même niveau que le sol, sans difficulté d'accès, à l'aide d'un support monté en usine avec ruban d'étanchéité intégré (illbruck based on Poresta® System).

I nuovi piatti doccia extra-sottili possono essere installati anche a filo pavimento utilizzando un supporto montato in fabbrica con nastro sigillante integrato (illbruck based on Poresta® System) e non presentano pertanto barriere architettoniche.

**Shower tray colours / Duschwannenfarben / Couleurs receveurs de douche / Colori piatti doccia**

-  **.000 White / Weiss / Blanc / Bianco**
-  **.049 Pergamon / Pergamon / Pergamon / Pergamon**

# Lb3 by LAUFEN

classic/modern



**Vanity unit classic/modern, 1 door, chromed handle, matches washbasin** 81068.4, 81068.5, 81268.3, 81268.4, 81268.5  
 Waschtischunterbau classic/modern, 1 Tür, Griff verchromt, passend zu Waschtischen 81068.4, 81068.5, 81268.3, 81268.4, 81268.5  
 Meuble sous lavabo classic/modern, 1 porte, poignée chromée, pour lavabos 81068.4, 81068.5, 81268.3, 81268.4, 81268.5  
 Base sottolavabo classic/modern, 1 ante, maniglia cromata, abbinabile ai lavabi 81068.4, 81068.5, 81268.3, 81268.4, 81268.5

**43610.1 Door hinge left**  
 Türanschlag links  
 Charnières de porte à gauche  
 Anta con apertura verso sinistra

**43610.2 Door hinge right**  
 Türanschlag rechts  
 Charnières de porte à droite  
 Anta con apertura verso destra

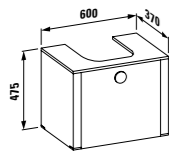

classic



**43611.1 Vanity unit classic, 2 doors, chromed handles, matches washbasin** 81068.6  
 Waschtischunterbau classic, 2 Türen, Griffe verchromt, passend zu Waschtisch 81068.6  
 Meuble sous lavabo classic, 2 portes, poignées chromées, pour lavabo 81068.6  
 Base sottolavabo classic, 2 ante, maniglie cromate, abbinabile al lavabo 81068.6

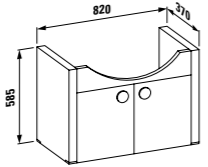

modern



**43612.1 Vanity unit modern, 2 doors, chromed handles, matches washbasin** 81268.6  
 Waschtischunterbau modern, 2 Türen, Griffe verchromt, passend zu Waschtisch 81268.6  
 Meuble sous lavabo modern, 2 portes, poignées chromées, pour lavabo 81268.6  
 Base sottolavabo modern, 2 ante, maniglie cromate, abbinabile al lavabo 81268.6

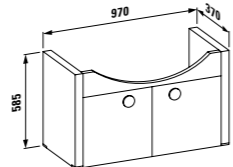

classic



**43613.1 Vanity unit classic, 2 doors, chromed handles, matches washbasin** 81068.8  
 Waschtischunterbau classic, 2 Türen, Griffe verchromt, passend zu Waschtisch 81068.8  
 Meuble sous lavabo classic, 2 portes, poignées chromées, pour lavabo 81068.8  
 Base sottolavabo classic, 2 ante, maniglie cromate, abbinabile al lavabo 81068.8

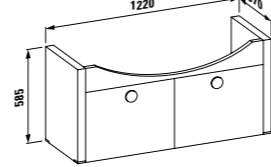

# Lb3 by LAUFEN

modern



**43314.1 Washbasin frame modern, with shelf, matches washbasin** 81368.1, 81368.2  
 Waschtisch-Untergestell modern, mit Ablage, passend zu Waschtischen 81368.1, 81368.2  
 Pied de lavabo avec étagère modern, pour lavabos 81368.1, 81368.2  
 Base sottolavabo con scaffale modern, abbinabile ai lavabi 81368.1, 81368.2

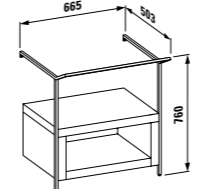

classic/modern



**46410.1 Trolley classic/modern with seating and interior drawer**  
 Rollcontainer classic/modern, mit Sitzfläche und Innenschublade  
 Container à roulettes classic/modern avec siège et tiroir intérieur  
 Base su ruote classic/modern con seduta e cassetto interno

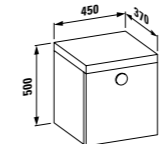

classic/modern



**46600.1\* Tall cabinet classic/modern, 4 glass shelves**  
 Hochschrank classic/modern, 4 Glasfachböden  
 Armoire classic/modern, 4 étagères en verre  
 Colonna classic/modern, 4 ripiani di vetro

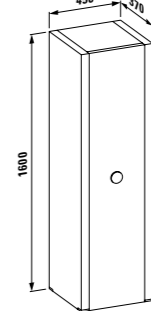

**43614.1 Optional foot set, 2 pieces (left/right), chromed surface**  
 Optionales Fuss-Set, 2 Stück (links/rechts), Oberfläche Chrom  
 Jeu de pieds optionnel, 2 pièces (gauche/droite), surface chromée  
 Set di piedini opzionale, 2 pezzi (sinistra/destra), superficie cromata

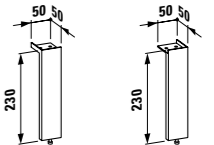

design



**Vanity unit design, 1 drawer, chromed handle, matches washbasin** 81468.1  
 Waschtischunterbau design, 1 Schublade, Griff verchromt, passend zu Waschtisch 81468.1  
 Meuble sous lavabo design, 1 tiroir, poignée chromée, pour lavabo 81468.1  
 Base sottolavabo design, 1 cassetto, maniglia cromata, abbinabile al lavabo 81468.1

**43311.1 Without interior drawer**  
 Ohne Innenschublade  
 Sans tiroir intérieur  
 Senza cassetto interno

**43311.2 With interior drawer**  
 Mit Innenschublade  
 Avec tiroir intérieur  
 Con cassetto interno

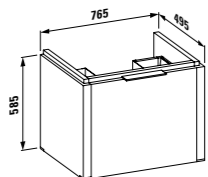

design



**Vanity unit design, 1 drawer, chromed handle, matches washbasin** 81468.2  
 Waschtischunterbau design, 1 Schublade, Griff verchromt, passend zu Waschtisch 81468.2  
 Meuble sous lavabo design, 1 tiroir, poignée chromée, pour lavabo 81468.2  
 Base sottolavabo design, 1 cassetto, maniglia cromata, abbinabile al lavabo 81468.2

**43312.1 Without interior drawer**  
 Ohne Innenschublade  
 Sans tiroir intérieur  
 Senza cassetto interno

**43312.2 With interior drawer**  
 Mit Innenschublade  
 Avec tiroir intérieur  
 Con cassetto interno

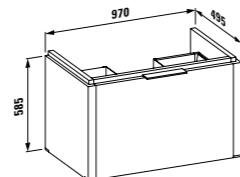

design



**Vanity unit design, 1 drawer, chromed handle, matches double washbasin** 81468.3  
 Waschtischunterbau design, 1 Schublade, Griff verchromt, passend zu Doppelwaschtisch 81468.3  
 Meuble sous lavabo design, 1 tiroir, poignée chromée, pour lavabo double 81468.3  
 Base sottolavabo design, 1 cassetto, maniglia cromata, abbinabile al lavabo doppio 81468.3

**43313.1 Without interior drawer**  
 Ohne Innenschublade  
 Sans tiroir intérieur  
 Senza cassetto interno

**43313.2 With interior drawer**  
 Mit Innenschublade  
 Avec tiroir intérieur  
 Con cassetto interno

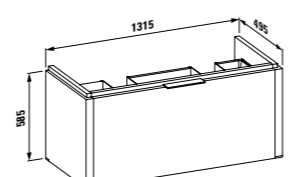

modern



**43315.1 Washbasin frame modern, with shelf, matches washbasin** 81368.3, 81368.4  
 Waschtisch-Untergestell modern, mit Ablage, passend zu Waschtischen 81368.3, 81368.4  
 Pied de lavabo avec étagère modern, pour lavabos 81368.3, 81368.4  
 Base sottolavabo con scaffale modern, abbinabile ai lavabi 81368.3, 81368.4

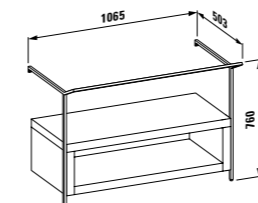

design



**46510.1 Trolley design with seating and interior drawer**  
 Rollcontainer design, mit Sitzfläche und Innenschublade  
 Container à roulettes design avec siège et tiroir intérieur  
 Base su ruote design con seduta e cassetto interno

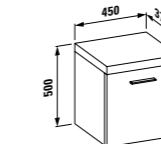

design



**46300.1\* Tall cabinet design, 4 glass shelves**  
 Hochschrank design, 4 Glasfachböden  
 Armoire design, 4 étagères en verre  
 Colonna design, 4 ripiani di vetro

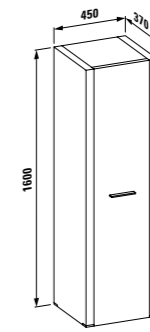



**44590.1**  
**Mirror 600 with 1 lighting element, 230V/40W IP44**  
 Spiegel 600 mit 1 Beleuchtungselement, 230V/40W IP44  
 Miroir 600 avec 1 élément d'éclairage, 230V/40W IP44  
 Specchio 600 con 1 elemento d'illuminazione, 230V/40W IP44

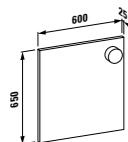

**44590.5**  
**Mirror 600 without lighting**  
 Spiegel 600 ohne Beleuchtung  
 Miroir 600 sans éclairage  
 Specchio 600 senza illuminazione

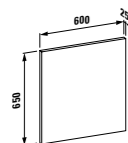

**44690.1**  
**Mirror 800 with 1 lighting element, 230V/40W IP44**  
 Spiegel 800 mit 1 Beleuchtungselement, 230V/40W IP44  
 Miroir 800 avec 1 élément d'éclairage, 230V/40W IP44  
 Specchio 800 con 1 elemento d'illuminazione, 230V/40W IP44

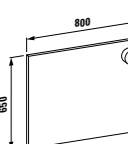

**44690.5**  
**Mirror 800 without lighting**  
 Spiegel 800 ohne Beleuchtung  
 Miroir 800 sans éclairage  
 Specchio 800 senza illuminazione

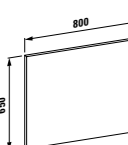

**44790.1**  
**Mirror 1200 with 1 lighting element, 230V/40W IP44**  
 Spiegel 1200 mit 1 Beleuchtungselement, 230V/40W IP44  
 Miroir 1200 avec 1 élément d'éclairage, 230V/40W IP44  
 Specchio 1200 con 1 elemento d'illuminazione, 230V/40W IP44

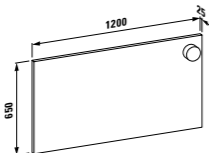

**44790.5**  
**Mirror 1200 without lighting**  
 Spiegel 1200 ohne Beleuchtung  
 Miroir 1200 sans éclairage  
 Specchio 1200 senza illuminazione

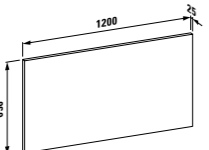

**Mirror cabinet with 1 lighting element, 230V/14W IP44, door hinges on lighting side**  
 Spiegelschrank mit 1 Beleuchtungselement, 230V/14W IP44, Türanschlag auf Beleuchtungsseite  
 Armoire de toilette avec 1 élément d'éclairage, 230V/14W IP44, charnières de porte côté éclairage  
 Armadietto a specchio, con 1 elemento d'illuminazione, 230V/14W IP44, anta con apertura dal lato dell'illuminazione

**44344.2\***  
**1 switch, 1 socket Europe**  
 1 Schalter, 1 Steckdose Europa  
 1 interrupteur, 1 prise Europe  
 1 interruttore, 1 presa Europa

**44345.2\***  
**No switch, 1 socket Switzerland**  
 Kein Schalter, 1 Steckdose Schweiz  
 Pas d'interrupteur, 1 prise Suisse  
 Senza interruttore, 1 presa Svizzera

**44346.2\***  
**No switch, no socket**  
 Kein Schalter, keine Steckdose  
 Pas d'interrupteur, pas de prise  
 Senza interruttore, senza presa

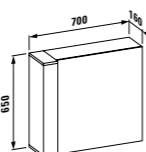

**Mirror cabinet with 1 lighting element, 230V/14W IP44, door hinges opposite to lighting side**  
 Spiegelschrank mit 1 Beleuchtungselement, 230V/14W IP44, Türanschlag gegenüber der Beleuchtung  
 Armoire de toilette avec 1 élément d'éclairage, 230V/14W IP44, charnières de porte en face de l'éclairage  
 Armadietto a specchio, con 1 elemento d'illuminazione, 230V/14W IP44, anta con apertura dal lato opposto all'illuminazione

**44344.3\***  
**1 switch, 1 socket Europe**  
 1 Schalter, 1 Steckdose Europa  
 1 interrupteur, 1 prise Europe  
 1 interruttore, 1 presa Europa

**44345.3\***  
**No switch, 1 socket Switzerland**  
 Kein Schalter, 1 Steckdose Schweiz  
 Pas d'interrupteur, 1 prise Suisse  
 Senza interruttore, 1 presa Svizzera

**44346.3\***  
**No switch, no socket**  
 Kein Schalter, keine Steckdose  
 Pas d'interrupteur, pas de prise  
 Senza interruttore, senza presa

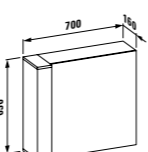

**Mirror cabinet with 2 lighting elements, 230V/14W IP44**  
 Spiegelschrank mit 2 Beleuchtungselementen, 230V/14W IP44  
 Armoire de toilette avec 2 éléments d'éclairage, 230V/14W IP44  
 Armadietto a specchio, con 2 elementi d'illuminazione, 230V/14W IP44

**44344.4\***  
**1 switch, 1 socket Europe**  
 1 Schalter, 1 Steckdose Europa  
 1 interrupteur, 1 prise Europe  
 1 interruttore, 1 presa europea

**44345.4\***  
**No switch, 1 socket Switzerland**  
 Kein Schalter, 1 Steckdose Schweiz  
 Pas d'interrupteur, 1 prise Suisse  
 Senza interruttore, 1 presa Svizzera

**44346.4\***  
**No switch, no socket**  
 Kein Schalter, keine Steckdose  
 Pas d'interrupteur, pas de prise  
 Senza interruttore, senza presa

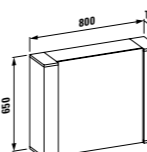

**44270.1\***  
**Small wall cabinet with mirror**  
 Spiegelschrank, klein  
 Armoire de toilette, petite  
 Armadietto a specchio, piccolo

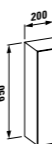

**44271.1\***  
**Side wall cabinet with mirror**  
 Regal mit Spiegel  
 Etagères à miroir  
 Scaffale con specchio



**44272.1\***  
**Open wall cabinet**  
 Offenes Regal  
 Etagères ouvertes  
 Scaffale aperto



**\* All wall units and tall cabinets are rotatable, accessible from left or right**  
 \* Alle Oberbauten und Hochschränke sind drehbar, von links oder rechts verwendbar  
 \* Tous les meubles hauts et armoires hautes sont pivotants et utilisables par la gauche ou la droite  
 \* Tutti i mobili pensili e le colonne sono girevoli, utilizzabili da sinistra o da destra

**Colours of furniture, surface reel wood veneer**  
 Möbelfarben, Oberfläche Echtholz furnier  
 Couleurs des meubles, surface placage en bois  
 Colori dei mobili, superficie vero legno impiallacciato

.560 White / Weiss / Blanc / Bianco

.561 Wenge / Wenge / Wengé / Wenge

.562 Oak / Eiche / Chêne / Rovere



38168.1  
**Towel rail, 300 mm, chrome surface**  
Handtuchhalter, 300 mm, Oberfläche Chrom  
Porte-serviettes, 300 mm, surface chromée  
Portasciugamani, 300 mm, superficie cromata

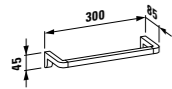

38168.2  
**Towel rail, 450 mm, chrome surface**  
Handtuchhalter, 450 mm, Oberfläche Chrom  
Porte-serviettes, 450 mm, surface chromée  
Portasciugamani, 450 mm, superficie cromata

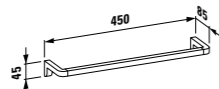

38168.3  
**Towel rail, 600 mm, chrome surface**  
Handtuchhalter, 600 mm, Oberfläche Chrom  
Porte-serviettes, 600 mm, surface chromée  
Portasciugamani, 600 mm, superficie cromata

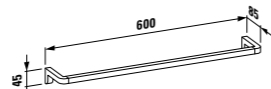

38168.4  
**Towel rack, 640 mm, chrome surface**  
Handtuchablage, 640 mm, Oberfläche Chrom  
Étagère porte-serviettes, 640 mm, surface chromée  
Ripiano per asciugamani, 640 mm, superficie cromata

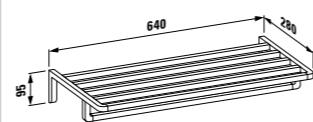

38568.2  
**Glass shelf, chrome surface**  
Glasablage, Oberfläche Chrom  
Étagère en verre, surface chromée  
Mensola di vetro, superficie cromata

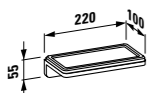

38568.1  
**Metal shelf, chrome surface**  
Metallablage, Oberfläche Chrom  
Étagère en métal, surface chromée  
Mensola di metallo, superficie cromata

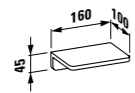

38368.1  
**Toilet roll holder with shelf, chrome surface**  
WC-Papierhalter mit Ablage, Oberfläche Chrom  
Porte-papier avec étagère, surface chromée  
Portarotolo con mensola, superficie cromata

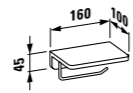

38768.1  
**Towel hook, chrome surface**  
Handtuchhaken, Oberfläche Chrom  
Crochet de serviette, surface chromée  
Gancio portasciugamani, superficie cromata



38368.2  
**Toilet brush holder with brush, freestanding, chrome surface**  
Bürstengarnitur, freistehend, Oberfläche Chrom  
Porte-balai avec balai, à poser, surface chromée  
Portascopino con scopino, d'appoggio, superficie cromata

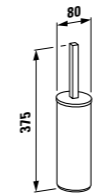

38468.1  
**Glass holder with crystal glass, wall-mounted, chrome surface**  
Glashalter mit Kristallglas, wandhängend, Oberfläche Chrom  
Porte-verre avec verre de cristal, mural, surface chromée  
Portabicchiere con bicchiere di cristallo, installazione a muro, superficie cromata

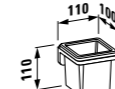

38468.3  
**Soap dispenser, with crystal glass, wall-mounted, chrome surface**  
Seifendispenser, mit Kristallglas, wandhängend, Oberfläche Chrom  
Distributeur de savon, avec verre de cristal, mural, surface chromée  
Dispenser portasapone, con vetro di cristallo, installazione a muro, superficie cromata

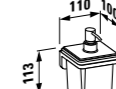

38468.2  
**Glass holder with crystal glass, wall-mounted, chrome surface**  
Glashalter mit Kristallglas, wandhängend, Oberfläche Chrom  
Porte-verre avec verre en cristal, mural, surface chromée  
Portabicchiere con bicchiere di cristallo, installazione a muro, superficie cromata

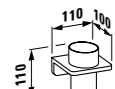

38568.2  
**Glass shelf, chrome surface**  
Glasablage, Oberfläche Chrom  
Étagère en verre, surface chromée  
Mensola di vetro, superficie cromata

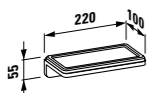

38568.1  
**Metal shelf, chrome surface**  
Metallablage, Oberfläche Chrom  
Étagère en métal, surface chromée  
Mensola di metallo, superficie cromata

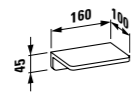

38368.1  
**Toilet roll holder with shelf, chrome surface**  
WC-Papierhalter mit Ablage, Oberfläche Chrom  
Porte-papier avec étagère, surface chromée  
Portarotolo con mensola, superficie cromata

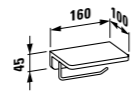

38768.1  
**Towel hook, chrome surface**  
Handtuchhaken, Oberfläche Chrom  
Crochet de serviette, surface chromée  
Gancio portasciugamani, superficie cromata



38468.0  
**Soap dish, with crystal glass, wall-mounted, chrome surface**  
Seifenschale, aus Kristallglas, wandhängend, Oberfläche Chrom  
Porte-savon, avec verre en cristal, mural, surface chromée  
Portasapone, con vetro di cristallo, installazione a muro, superficie cromata

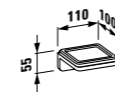

38468.6  
**Combo soap dish and glass holder, with crystal glass, wall-mounted, chrome surface**  
Kombi Seifenschale und Glashalter, mit Kristallglas, wandhängend, Oberfläche Chrom  
Jeu de porte-savon avec porte-verre, avec verre de cristal, mural, surface chromée  
Set portasapone e bicchiere, con vetro di cristallo, installazione a muro, superficie cromata

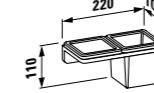

38468.5  
**Combo crystal soap dispenser and glass, wall-mounted, chrome surface**  
Kombi Kristall Seifendispenser und Glas, wandhängend, Oberfläche Chrom  
Jeu de distributeur de savon et de verre de cristal, mural, surface chromée  
Set dispenser portasapone e bicchiere di cristallo, installazione a muro, superficie cromata

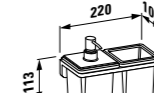

38468.7  
**Glass holder with 2 crystal glasses, wall-mounted, chrome surface**  
Glashalter mit 2 Kristallgläsern, wandhängend, Oberfläche Chrom  
Porte-verre double avec 2 verres en cristal, mural, surface chromée  
Portabicchiere doppio, con 2 bicchieri di cristallo, installazione a muro, superficie cromata

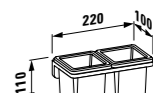



3.1168.1.004.121.1  
**Basin single-lever mixer, fixed spout 130 mm, with pop-up waste**

*Waschtischmischer, Festauslauf 130 mm, mit Ablaufventil*  
*Mitigeur de lavabo, bec fixe, saillie 130 mm, avec vidage*  
*Miscelatore per lavabo, bocca di erogazione fissa, sporgenza 130 mm, con piletta*

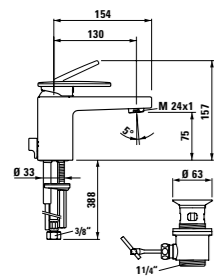

3.1268.3.004.121.1  
**Three holes basin mixer, fixed spout 130 mm, with pop-up waste**

*Zweigriffmischer, Festauslauf 130 mm, mit Ablaufventil*  
*Mélangeur de lavabo 3 trous, bec fixe, saillie 130 mm, avec vidage*  
*Miscelatore per lavabo a 3 fori, bocca di erogazione fissa, sporgenza 130 mm, con piletta*

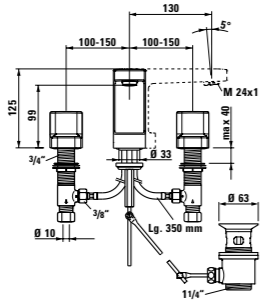

3.4168.1.004.121.1  
**Bidet single-lever mixer, fixed spout 130 mm, with pop-up waste**

*Bidetmischer, Festauslauf 130 mm, mit Ablaufventil*  
*Mitigeur de bidet, bec fixe, saillie 130 mm, avec vidage*  
*Miscelatore per bidet, bocca di erogazione fissa, sporgenza 130 mm, con piletta*

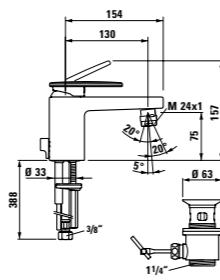

3.2168.7.004.146.1  
**Bath single-lever mixer complete, with flexible hose 1800 mm and Aquajet Multi handspray**

*Bademischer komplett, mit Kunststoffschlauch 1800 mm und Handbrause Aquajet Multi*  
*Mitigeur de bain complet, avec flexible synthétique 1800 mm et douche à main Aquajet Multi*  
*Miscelatore da bagno completo, tubo sintetico 1800 mm e doccia a mano Aquajet Multi*

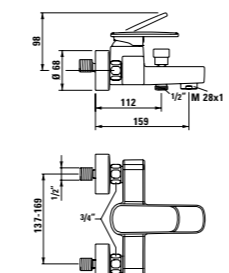

3.3168.7.004.146.1  
**Shower single-lever mixer complete, with flexible hose 1800 mm and Aquajet Multi handspray**

*Duschenmischer komplett, mit Kunststoffschlauch 1800 mm und Handbrause Aquajet Multi*  
*Mitigeur de douche complet, avec flexible synthétique 1800 mm et douche à main Aquajet Multi*  
*Miscelatore per doccia completo, con tubo sintetico 1800 mm e doccia Aquajet Multi*

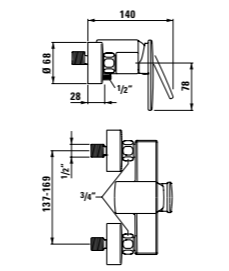

3.2168.6.004.000.1  
**Concealed bath mixer with diverter**  
*Fertigmontage-Set für UP-Bademischer, mit Umsteller*  
*Décor pour mitigeur de bain encastré, avec inverseur*  
*Miscelatore da bagno ad incasso con deviatore*

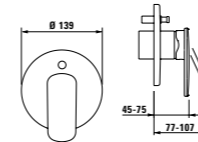

3.7898.0.000.000.1  
**Simibox**  
**Concealed system to be ordered separately**  
*UP-Einbaukörper separat bestellbar*  
*Corps encastrable à commander séparément*  
*Corpo ad incasso da ordinare separatamente*



3.3168.6.004.000.1  
**Concealed shower mixer**  
*Fertigmontage-Set für UP-Duschenmischer*  
*Décor pour mitigeur de douche encastré*  
*Miscelatore da doccia ad incasso*

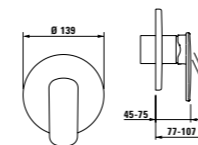

3.7898.0.000.000.1  
**Simibox**  
**Concealed system to be ordered separately**  
*UP-Einbaukörper separat bestellbar*  
*Corps encastrable à commander séparément*  
*Corpo ad incasso da ordinare separatamente*



3.1168.6.004.120.1  
**Concealed wall mixer, fixed spout 184 mm**  
*Fertigmontage-Set für UP-Waschtischmischer, Festauslauf 184 mm*  
*Décor pour mitigeur de lavabo encastré, bec fixe, saillie 184 mm*  
*Miscelatore a parete da incasso, bocca di erogazione fissa 184 mm*

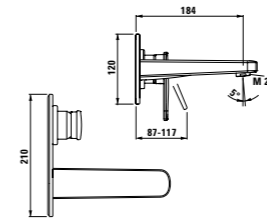

3.7698.1.000.200.1  
**Rough-in set LW-40 to be ordered separately**  
*Rohbausatz LW-40 separat bestellbar*  
*Set de montage brut LW-40 à commander séparément*  
*Set di montaggio brutto LW-40 da ordinare separatamente*



3.7168.0.004.060.1  
**Wall spout, 185 mm**  
*Wanneneinlauf, Festauslauf 185 mm*  
*Goulot mural, saillie 185 mm*  
*Bocca di erogazione vasca a muro, 185 mm*

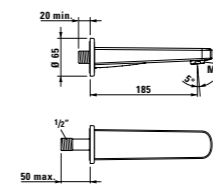

3.2068.4.004.284.1  
**Roman tub filler 4-holes, without plate, with flexible hose 2000 mm**  
*Wannenfüllkombination 4-Loch, ohne Platte, mit Kunststoffschlauch 2000 mm*  
*Garniture de remplissage de baignoire 4 trous, sans plaque, avec flexible synthétique 2000 mm*  
*Rubinetteria per vasca, 4 fori, senza piastra, con tubo sintetico 2000 mm*

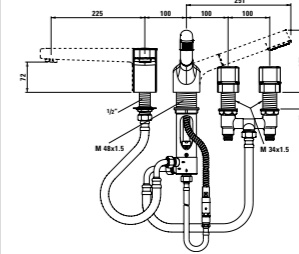

3.2268.4.004.284.1  
**Roman tub filler 4-holes, on straight plate, with flexible hose 2000 mm**  
*Wannenfüllkombination 4-Loch, auf Platte, mit Kunststoffschlauch 2000 mm*  
*Garniture de remplissage de baignoire 4 trous, sur plaque, avec flexible synthétique 2000 mm*  
*Rubinetteria per vasca, 4 fori, con piastra, con tubo sintetico 2000 mm*

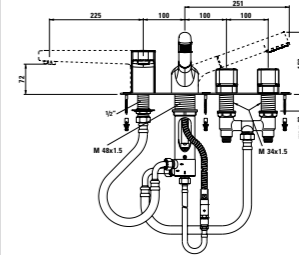

3.6498.0.004.300.1  
L = 600 mm  
3.6498.0.004.400.1  
L = 1100 mm  
**SimiGliss**  
**Shower bar**  
*SimiGliss*  
*Duschengleitstange*  
*SimiGliss*  
*Glissière de douche*  
*SimiGliss*  
*Asta per doccia*

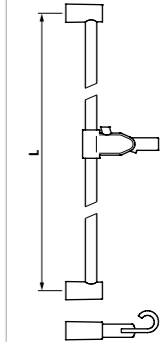

3.6998.0.004.600.1  
**Fixed shower holder**  
*Fester Halter für Handbrause*  
*Support fixe pour douchette*  
*Supporto fisso per doccia*

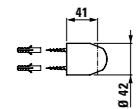

**Quality faucets from SimilorGroup for Laufen**  
*Qualitätsarmaturen von SimilorGroup für Laufen*  
*Robinetteria de qualità de SimilorGroup pour Laufen*  
*Rubinetteria di qualità di SimilorGroup per Laufen*





Swiss Quality

It is possible that not all products, sizes or colours are available in every country. Delivery periods may also differ in each case.

Unter Umständen sind nicht alle Produkte, Größen oder Farben in jedem Land verfügbar. Auch die jeweiligen Lieferzeiten können von Land zu Land abweichen.

Il se peut que les produits ne soient pas tous disponibles dans chaque pays dans toutes les dimensions et coloris. Les délais de livraisons peuvent également varier d'un pays à l'autre.

È possibile che non tutti i prodotti, le misure e i colori siano ugualmente disponibili in ogni Paese. Anche i tempi di consegna possono variare da un Paese all'altro.

The illustrated colours only approximately correspond to the actual shades. The bathroom layouts shown here are purely decorative and do not reflect all the technical requirements. The decorative parts used are not included in our commercial offer. We reserve the right to make technical changes without prior notice. Registered design.

Die Farbabbildungen entsprechen nur in etwa den tatsächlichen Farbtönen. Die hier gezeigten Badmilieus sind rein dekorativ und berücksichtigen nicht alle technischen Anforderungen. Unser Angebot beinhaltet nicht die verwendete Dekoration. Technische Änderungen sind vorbehalten. Design geschützt.

Les photos couleur ne correspondent que partiellement aux teintes effectives. Les ambiances reproduites ici sont simplement décoratives, les exigences techniques d'installation n'ont pas toujours été prises en compte. La décoration utilisée ne fait pas partie de notre offre commerciale. Sous réserve de modifications techniques. Modèle déposé.

I colori qui illustrati non corrispondono esattamente alle tonalità effettive. Gli ambienti qui riprodotti sono puramente decorativi e non tengono conto di tutte le specifiche tecniche. Gli articoli d'arredo usati non fanno parte della nostra offerta commerciale. Con riserva di apportare modifiche tecniche. Modello depositato.

Products with the Q-Plus certification comply with the European standard, as well as with the proven higher Swiss standard laid down by suissetec/VSA. LAUFEN ceramic products comply with this Swiss quality standard and are recommended accordingly.

Produkte mit der Q-Plus-Zertifizierung entsprechen einerseits der Europeanorm und andererseits zusätzlich dem bewährten, höheren Schweizer Standard, welcher durch die suissetec/VSA festgelegt wurde. LAUFEN Keramikprodukte entsprechen diesen schweizerischen Qualitätsmassstäben und haben die entsprechende Zulassungsempfehlung.

Les produits avec certification Q-Plus correspondent à la norme européenne et satisfont en plus aux standards suisses définis par la suissetec/VSA, encore plus élevés et qui ont largement fait leurs preuves. Les produits en céramique signés LAUFEN sont conformes à ces critères de qualité suisses et bénéficient donc des recommandations d'homologation correspondantes.

I prodotti con la certificazione Q-Plus sono conformi, da un lato, alla normativa europea e, dall'altro, anche allo standard svizzero, che prevede requisiti ancora più rigorosi, stabiliti dalla suissetec/VSA. I prodotti in ceramica LAUFEN rispettano questi criteri qualitativi svizzeri e dispongono della relativa certificazione di qualità.

Printed on certified paper from sustainably managed forests.

Gedruckt auf zertifiziertem Papier. Aus nachhaltig bewirtschafteten Wäldern.

Imprimé sur du papier certifié. Issu de forêts exploitées de façon durable.

Stampato su carta certificata. Proveniente da boschi a gestione sostenibile.

Asia:

Roca Asia Ltd. Room 2303, 23/F 148 Electric Road North Point, Hong Kong Tel. +852 250 624 38 Fax +852 250 624 92 laufenasia@hongkong.laufen.ch www.laufen.com/export

Australia, New Zealand and Oceania:

Roca Group Suite 304, Level 3 191 Clarence Street Sydney, 2000 NSW, Australia Tel. +61 (2) 9290 2331 Fax +61 (2) 9290 2786 josep.royo@roca.net www.laufen.com

Austria:

LAUFEN Austria AG Mariazeller Strasse 100 A-3150 Wilhelmsburg Tel. +43 2746 6060 Fax +43 2746 6060 380 office@at.laufen.com www.laufen.co.at

Benelux:

LAUFEN Benelux B.V. Postbus 2702 NL-3800 GG Amersfoort Tel. +31 (0)33 450 20 90 Fax +31 (0)33 450 20 91 info@laufen.nl www.laufen.nl www.laufen.be

Bulgaria:

Roca Bulgaria Pirotska Street, 5 1421 Sofia/Bulgaria Tel. +359 02 93 05 910 Fax +359 02 93 05 918 office.sofia@bg.roca.net www.roca-bulgaria.bg

China:

Roca Sanitary Trading (Shanghai) co. Ltd Room 503-505, City Gateway No. 396 North Caoxi Road Shanghai 200030, China Tel. +86 21 3368 8822 Fax +86 21 3368 8299 enquiries@roca.net.cn www.roca.cn

Croatia, Serbia, Bosnia, Herzegovina:

LAUFEN CZ s.r.o. Jagodno 102 10415 Novo Čiče Hrvatska Tel./Fax +385 1 619 56 76 office.zagreb@hr.laufen.com www.laufen.com/hr

Czech Republic:

LAUFEN CZ s.r.o. V Tüních 3/1637 120 00 Praha 2 Tel. +420 296 337 711 Fax +420 296 337 713 marketing@cz.laufen.com www.laufen.com/cz

Estonia, Latvia:

LAUFEN CZ s.r.o. Pae 25-8 Tallinn, 11414 Estonia Tel./Fax +372 6 215 569 office.tallinn@ee.laufen.com www.laufen.com

France:

LAUFEN France 19-21, rue de Bretagne Z.I. des Béthunes F-95310 St-Ouen-L'Aumône Cedex Tel. +33 1 34 40 39 31 Fax +33 1 30 37 02 65 commercial@laufen-france.com www.laufen.com/fr

Germany:

Roca GmbH Vertrieb LAUFEN Feincheswiese 17 56424 Staudt Tel. +49 26 02 / 94 93 33 Fax +49 26 02 / 94 93 355 info.staudt@de.laufen.com www.laufen.com/de

Hungary:

LAUFEN CZ s.r.o. Ördögárok u. 121 H-1029 Budapest Magyarország Tel. +36 1 376 96 24 Fax +36 1 376 96 24 office.budapest@hu.laufen.com www.laufen.com

Italy:

LAUFEN Italia s.r.l. Via Leonardo da Vinci, 24 I-20080 Casarile (MI) Tel. +39 02 900 25 88 Fax +39 02 905 21 74 www.laufen.it

Lithuania:

LAUFEN CZ s.r.o. Užupio g. 30 Vilnius, 01203 Lietuva Tel. +370 5 215 30 76 Fax +370 5 215 30 86 office.vilnius@lt.laufen.com www.laufen.com/lt

Morocco:

Roca Maroc, S.A. route de Marrakech, km 2,5 BP 571, 26000 Settat Tel. +212 23 40 59 41 Fax +212 23 40 59 42 www.roca.ma

Nordic:

Laufen Nordic ApS Fejovej 8 DK-4652 Haarlev Tel. +45 56 287 287 Fax +45 56 287 237 info@dk.laufen.com www.laufen.com/export

Poland:

Roca Polska Sp. z o.o. ul. Wyczółkowskiego 20 44-109 Gliwice Tel. +48 32 339 41 00 Fax +48 32 339 41 01 biuro@roca.pl www.laufen.com

Portugal:

Roca, S.A., Portugal Apartado 575, Ponte da Madalena 2416-905 - Leiria, Portugal Tel. +351 244 720 000 Fax +351 244 722 373 marketing.le@pt.roca.net www.laufen.pt

Romania:

LAUFEN CZ s.r.o. Str. Matei Basarab nr. 82 500008 Brasov Tel./Fax +40 268 413 609 Mobil: +40 749 075 174 office.bucharest@ro.laufen.com

Russia:

Roca Santekhnika Promyshlennaya Str. 7, Tosno Leningrad region, 187000, Russia Tel. +7 812 347 94 49 Fax +7 812 347 94 50 office.moscow@ru.laufen.com www.laufen.ru

Roca Santekhnika

Altufievskoye shosse, 1/7 Moscow, 127106, Russia Tel. +7 (495) 956 33 30 Tel. +7 (495) 230 65 48 Fax +7 (495) 234 07 97 office.moscow@ru.laufen.com www.laufen.ru

Slovakia:

LAUFEN SK s.r.o. Štefanovičova 12 811 04 Bratislava Tel. +421 2 526 210 24 Fax +421 2 526 210 25 office.bratislava@sk.laufen.com www.laufen.com/sk

Slovenia, Montenegro, Macedonia, Albania, Moldova:

LAUFEN CZ s.r.o. Ul. Ivana Regenta 2 SI-6310 IZOLA, Slovenia Tel. +386(0)5 640 12 12 Mob. +386(0)31 342 567 Fax +386(0)5 640 12 12 office.ljubljana@si.laufen.com

Spain:

LAUFEN Av Diagonal 513 08029 Barcelona Tel. +34 93 366 12 00 Fax +34 93 430 20 19 infosan@roca.es www.laufen.es

Switzerland:

Keramik Laufen AG Wahlenstrasse 46 CH-4242 Laufen Tel. +41 61 765 75 75 Fax +41 61 766 56 53 forum@laufen.ch www.laufen.ch

Ukraine:

LAUFEN CZ s.r.o. Ukraine Kiev 04128 19, Ak. Tupoleva str., office „Laufen“ Tel. +380 44 499 0620 Fax +380 44 499 0621 office.kiev@ua.laufen.com www.laufen.net.ua

United Kingdom and Ireland:

LAUFEN Ltd. c/o Roca Ltd. Samson Road Hermitage Industrial Estate Coalville Leicestershire LE67 3FP Tel. +44 (0)1530 510007 Fax +44 (0)1530 838949 info@uk.laufen.com www.laufen.co.uk

Export:

LAUFEN Bathrooms AG Wahlenstrasse 46 CH-4242 Laufen Tel. +41 61 765 76 09 Fax +41 61 761 10 20 export@laufen.ch www.laufen.com/export

Headquarters:

LAUFEN Bathrooms AG Wahlenstrasse 46 CH-4242 Laufen Tel. +41 61 765 71 11 Fax +41 61 761 36 60 feedback@laufen.ch www.laufen.com

Product design Ceramics: Ludovica+Roberto Palomba, Milano Faucets and mixers: Jürg Heuberger, Laufen Bathrooms Brochure Photos: Max Zambelli, Maurizio Marcato Styling: ps+a Graphics & concept: ps+a, Laufen Bathrooms Thanks to Acca Kappa, Fantechi s.r.l, Kartell, Lema, Oscar Maschera, Sant' Agostino, Swan, Triangolo

Table with 2 columns: Edition, Ausgabe, Edition, Edizione and 2 rows of dates: 10/2009

