

**RAK-SILVER**

**RAK**  
CERAMICS

## ICONS

## TECHNICAL INFORMATION

Informazioni Tecniche  
Informations Techniques  
Technische Informationen  
Техническая информация



**BACK TO WALL CLOSE COUPLED WC**  
WC monoblocco a filo muro  
WC monobloc posé au sol  
Rückwandmontage Tiefsput WC  
Пристенный унитаз-компакт



**BACK TO WALL WC**  
WC a filo muro  
WC posé au sol  
Rückwandmontage WC  
Приставной унитаз



**WALL HUNG WC**  
WC sospeso  
WC contre le mur  
Wandhängendes WC  
Подвесной унитаз



**WALL HUNG BIDET**  
Bidet sospeso  
Bidet suspendu au mur  
Wandhängendes Bidet  
Подвесное биде



**SHOWER TRAY**  
Piatto doccia in  
Receveur de douche en  
Duschwanne  
Душевой поддон



**WALL HUNG VANITY UNIT**  
Mobile sospeso  
Meuble suspendu  
Waschtisch, wandhängend  
Подвесная тумба



**WALL HUNG TALL STORAGE UNIT**  
Colonna sospesa  
Colonne grande hauteur suspendue  
Hoher Aufbewahrungsschrank, wandhängend  
Подвесной пенал



**WALL HUNG MIRROR CABINET**  
Specchio contenitivo sospeso  
Armoire toilette  
Wandspiegelschrank  
Подвесной шкаф с зеркалом



**DROP IN WASH BASIN**  
Incasso  
A encastrer  
Einbau  
Встраиваемая Раковина



**SOFT CLOSE HINGES**  
Cerniere a chiusura rallentata  
Charnières amorties  
Scharnier mit integrierter Dämpfung  
Крепежи с функцией плавного закрытия



**SOFT CLOSE DRAWER RUNNERS**  
Guide a chiusura rallentata  
Coulisses avec système de fermeture progressive  
Läufer mit integrierter Dämpfung  
Направляющие для ящиков с функцией плавного закрытия



**J-PULL FRONTALS**  
Frontali con maniglia integrata J-pull  
Prise de main J-pull  
J-Pull Frontals  
J-Pull дверцы



**ADJUSTABLE GLASS SHELVING**  
Ripiani regolabili in vetro  
Étagère en verre réglable  
Verstellbare Glasregale  
Регулируемые стеклянные полки



**REVERSIBLE**  
Reversible  
Réversible  
Reversibel  
Реверсионный



**DE-MISTER**  
Anti-appannamento  
Système antibuée  
Entnebler  
Антизапотеватель



**P-TRAP**  
A parete  
Murale  
P-Falle  
Выход в стену



**S-TRAP**  
A terra  
Au sol  
S-Falle  
Выход в пол



**SOFT CLOSE**  
Chiusura morbida  
Avec fermeture  
Slow-close  
Плавное закрытие



**QUICK RELEASE**  
Montaggio rapido  
À Démontage rapide  
Abnehmbar  
Быстроръемное



**MAINS POWERED**  
Alimentazione da rete  
Alimentation secteur  
Netz betrieben  
Питание от сети



**MOTION SENSOR**  
Sensore di movimento  
Capteur de mouvement  
Bewegungssensor  
Датчик движения



**LIGHT**  
Luce  
Lumière  
Licht  
Свет



**USB RECHARGEABLE**  
Ricaricabile via USB  
USB rechargeable  
USB wiederaufladbar  
USB-подзаряжаемый



**GRAB BARS**  
Maniglioni  
Barres de relèvement  
Haltegriffe  
поручни



**SPRAY DOUCHE SET**  
Doccetta Bidet  
Bidet-douche  
Duschbidet  
Душ-биде



**COMPATIBLE WITH 4.5L DUAL FLUSHING. FACTORY SETTING IS 6L**  
Compatible con doppio scarico 4.5l.  
Preconfigurato a 6l.  
Compatible avec le système de double chasse à 4.5 litres. Calibrage de fabrication 6 litres.  
Kompatibel mit dem Spülregulierungssystem mit 4.5 Liter. Herstellereinstellung 6 Liter.  
Заводская настройка двойного смыва - 6 литров. Возможна настройка смыва на 4,5 литра.

**HIDDEN FIXATIONS**  
Fissaggio Nascosto  
Fixation Invisible  
Versteckte Befestigung  
Скрытая Фиксация

**COMFORT HEIGHT 42 CM**  
Altezza Comfort 42 CM  
Cuvette WC Hauteur 42 CM  
Komfortable Höhe 42 CM  
Оптимальная высота 42 см

**BACK OPEN**  
Apertura Posteriore  
Cuvette WC Non Adossée Au Mur  
Rückseite Offen  
Открытая задняя часть

## RAK-SILVER

The pleasure of independence, at any age

Just a few small changes are enough to turn your bathroom into a safe environment, even if you are in your twilight years or have limited movement. The RAK-Silver collection has been created by RAK Ceramics to provide safety, functionality and comfort at any age, with essential features to ensure total independence and autonomy in your bathroom, without sacrificing on style. Including anti-slip shower trays that are flush to the floor, sanitary ware fittings with increased height to facilitate easier sitting and standing, and grab bars that combine functionality and design, our RAK-Silver collection provides a full range of stylish and practical solutions for seniors. RAK-Silver breaks down every barrier, transforming your bathroom into a pleasant and safe space in which you can relax in total comfort.



Bastano pochi specifici accorgimenti per trasformare il bagno in un ambiente sicuro anche per persone non più giovani o con limitazioni di movimento. Rak-Silver è uno specifico programma creato da Rak Ceramics per poter garantire sicurezza, funzionalità e comfort ad ogni età, caratteristiche indispensabili per assicurare totale indipendenza ed autonomia nella zona bagno, senza rinunciare al proprio stile. Nascono così i piatti doccia antiscivolo a filo pavimento, i sanitari ad altezza maggiorata per facilitare seduta ed alzata, i maniglioni che uniscono funzionalità e design, diventando veri e propri complementi d'arredo e tutte le altre soluzioni contenute nel programma Rak-Silver. Rak-Silver abbatte ogni barriera restituendo uno spazio piacevole e sicuro: un bagno tutto da vivere.



Es genügen wenige spezifische Kunstgriffe, um das Badezimmer in einen sicheren Raum zu verwandeln, selbst für ältere oder bewegungseingeschränkte Personen. Rak-Silver ist ein spezifisches Programm, das von Rak-Ceramics entwickelt worden ist, um Sicherheit, Funktionalität und Komfort in jedem Alter zu garantieren - unerlässliche Eigenschaften, um eine völlige Unabhängigkeit und Autonomie im Badbereich sicherzustellen, ohne auf den eigenen Stil verzichten zu müssen. So entstehen rutschfeste bodengleiche Duschbecken, erhöhte sanitäre Gegenstände, um das Hinsetzen und das Aufstehen zu erleichtern, Griffe, die Funktionalität und Design vereinen, und somit zu wahrhaftigen Einrichtungskomplementen werden, sowie alle anderen Lösungen, die im Programm Rak-Silver enthalten sind. Rak-Silver überwindet jede Barriere und schafft einen angenehmen und sicheren Raum: ein Badezimmer zum leben.



Es genügen wenige spezifische Kunstgriffe, um das Badezimmer in einen sicheren Raum zu verwandeln, selbst für ältere oder bewegungseingeschränkte Personen. Rak-Silver ist ein spezifisches Programm, das von Rak-Ceramics entwickelt worden ist, um Sicherheit, Funktionalität und Komfort in jedem Alter zu garantieren - unerlässliche Eigenschaften, um eine völlige Unabhängigkeit und Autonomie im Badbereich sicherzustellen, ohne auf den eigenen Stil verzichten zu müssen. So entstehen rutschfeste bodengleiche Duschbecken, erhöhte sanitäre Gegenstände, um das Hinsetzen und das Aufstehen zu erleichtern, Griffe, die Funktionalität und Design vereinen, und somit zu wahrhaftigen Einrichtungskomplementen werden, sowie alle anderen Lösungen, die im Programm Rak-Silver enthalten sind. Rak-Silver überwindet jede Barriere und schafft einen angenehmen und sicheren Raum: ein Badezimmer zum leben.



Даже если вы находитесь в преклонном возрасте или ваши возможности перемещения ограничены, достаточно нескольких небольших изменений, чтобы сделать вашу ванную комнату безопасной. Коллекция RAK-Silver была создана RAK Ceramics, чтобы обеспечить безопасность, функциональность и комфорт в любом возрасте. Коллекция обладает необходимыми функциями для гарантии полной независимости и самостоятельности в вашей ванной комнате, не принося в жертву дизайн. Коллекция RAK-Silver предлагает полный спектр стильных и практичных решений для пожилых людей и включает в себя противоскользящие душевые поддоны, встроенные в пол, сантехнические изделия с увеличенной высотой для облегчения сидения и стояния, а также поручни, которые сочетают в себе функциональность и дизайн. Наша коллекция RAK-Silver предлагает полный спектр стильных и практичных решений для пожилых людей.

All ceramic cistern codes refer to bottom inlet version; all washbasin codes refer to one tap hole version, unless differently specified.

Tutti i codici per le cisterne si riferiscono alla versione con carico dal basso; tutti i codici dei lavabi si riferiscono alla versione con un foro, se non diversamente specificato

l'entrée de l'eau de tous les réservoirs pour nos wc monobloc ets positionnée dans la partie inférieure; tous nos lavabos sont prévus avec un seul trou pour les robinets (sauf specification différente)

Alle Zulaufe für den Spülkasten befinden sich im unteren Bereich des WCs; Alle Kodes der Waschbecken beziehen sich auf die Version mit einem Loch, falls nicht anders angegeben.

Если иное не указано, все коды для керамического бачка относятся к варианту с впускным отверстием снизу; все коды для умывальника относятся к варианту с одним отверстием для крана.



-  81 x 46 CM
-  W 80 x D 46 x H 60CM
-  850mm (32mm DIA.)
-    55 CM
-  RAK-Duo
-  90 x 170 CM

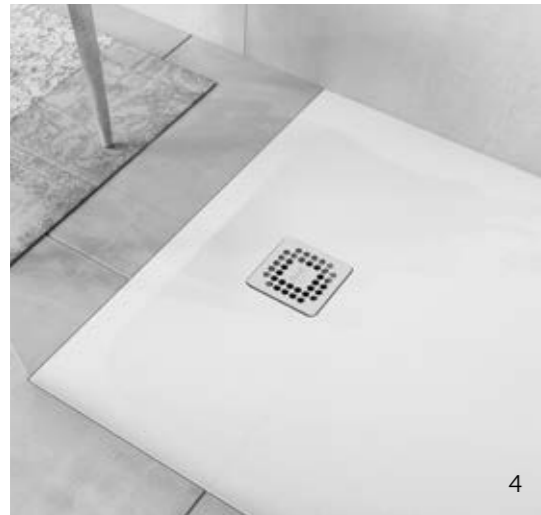
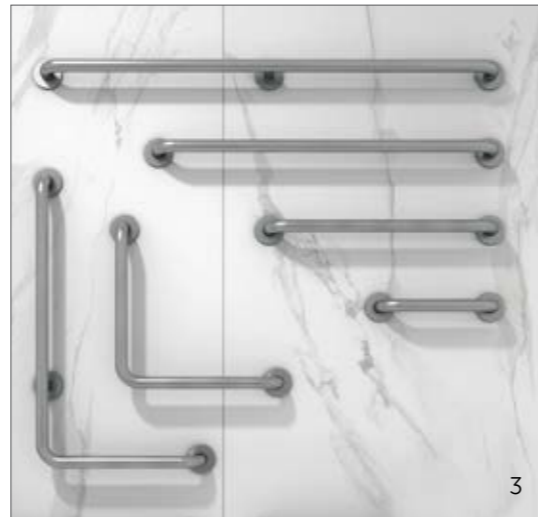

- 1 Make your toilet more comfortable, choose a h45cm WC comfort height
- 2 Replace the comfort of your bidet with a spray douche (shataff)
- 3 Install quality design grab bars
- 4 Replace your bathtub with a walk-in anti slip shower tray
- 5 Install a comfortable and safe shower seat in your shower
- 6 Organize your medicinal products and first aid kit in capient and functional cabinet mirrors and furniture storage



FOR YOUR SELF-SUFFICIENCY  
AND **TOTAL** INDEPENDENCE,

EQUIP YOUR BATHROOM IN 6 EASY STEPS



SMART SOLUTIONS  
FOR SENIOR NEEDS

# RAK-RESORT COMFORT HEIGHT

Models | Modelli | Modèles | Modelle | Модели



**65 CM**  
RST16AWHA  
RST10AWHA

Comfort Height 45 Cm



**65 CM**  
RST11AWHA  
RST10AWHA

Back open

Comfort Height 45 Cm



**55 CM**  
RST21AWHA

Comfort Height 45 Cm



**52 CM**  
RST23AWHA

Hidden Fixations



**52 CM**  
RST07AWHA

Hidden Fixations

Measurements | Misure | Dimensions | Abmessungen | Размеры

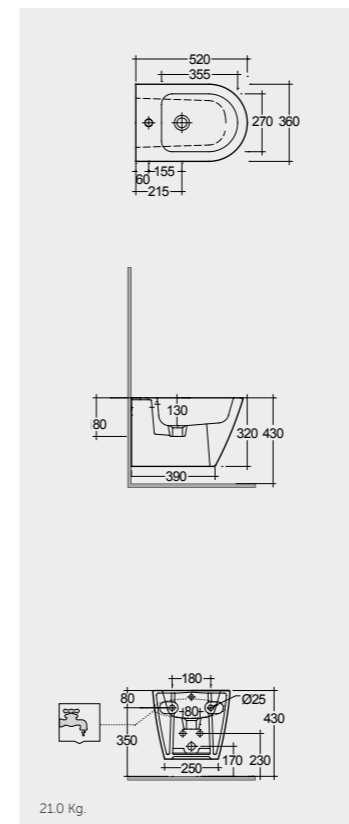
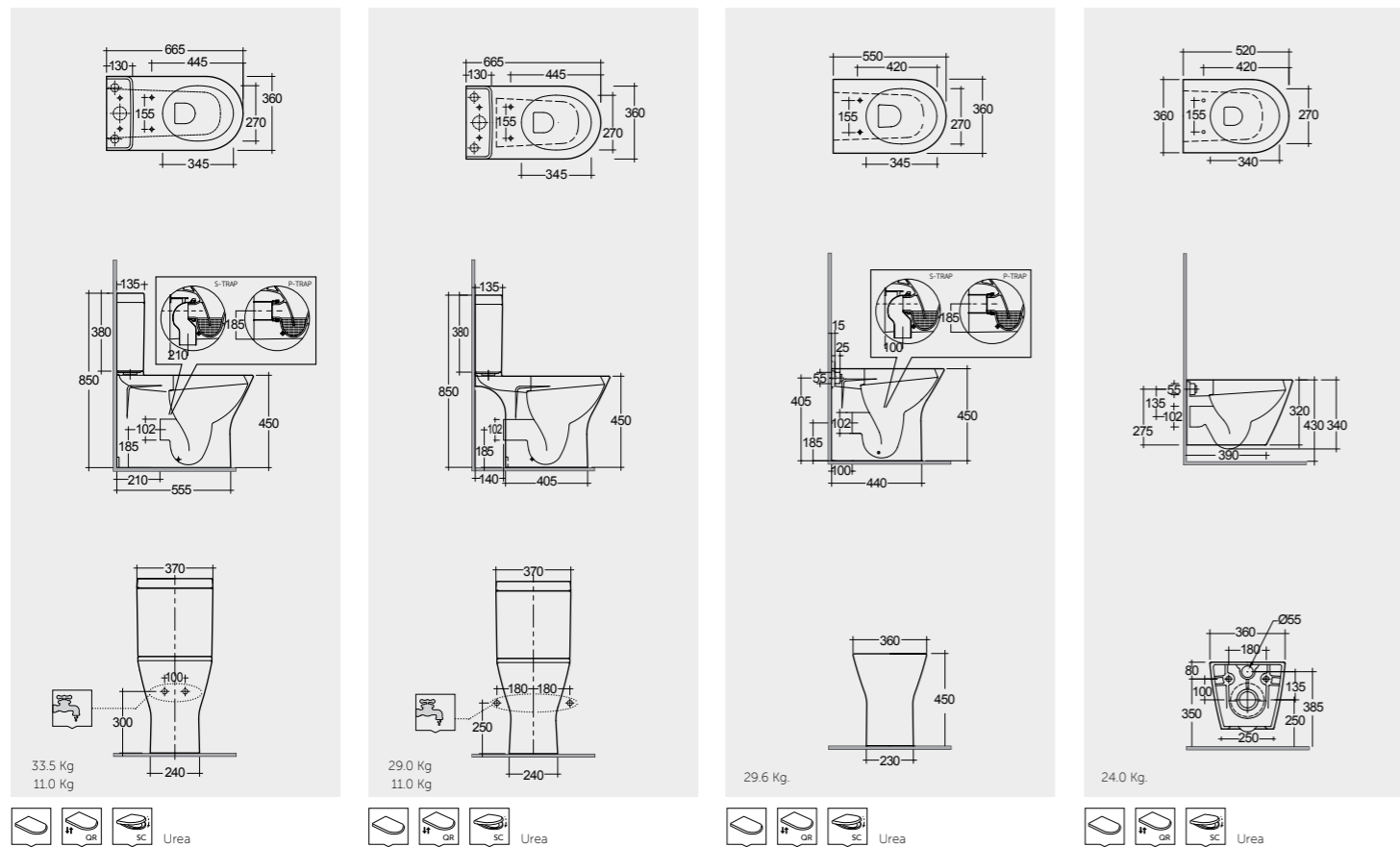

Note | Nota | Remarque | Hinweis | Примечание

All dimensions in mm tolerance +5% for below 200mm and +3% for above 200mm | Tutte le dimensioni hanno una tolleranza di +5% mm al di sotto dei 200mm e di +3% mm al di sopra dei 200mm | Toutes les dimensions en mm tolérance +5% pour moins de 200mm et +3% pour plus de 200mm/ Alle Abmessungen in mm, Toleranz +5% für unter 200mm, und +3% für über 200mm | Все размеры указаны в мм, погрешность — +5% ниже 200 мм и +3% выше 200 мм

# COMFORT HEIGHT / RAK-COMPACT

Models | Modelli | Modèles | Modelle | Модели



Rimless

62 CM  
CO26AWHA  
CO10AWHA

Comfort Height 45 Cm



Rimless

62 CM  
CO30AWHA  
CO10AWHA

Back open

Comfort Height 45 Cm



Rimless

52 CM  
SP18AWHA

Comfort Height 45 Cm



Rimless

52 CM  
CO27AWHA

Hidden Fixations



52 CM  
CO28AWHA

Hidden Fixations

Measurements | Misure | Dimensions | Abmessungen | Размеры

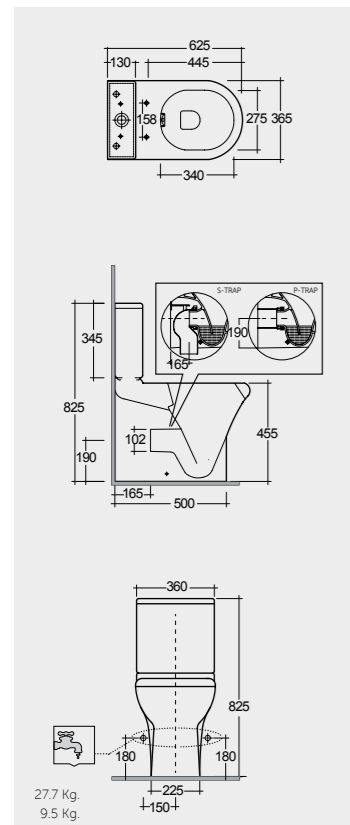

27.7 Kg.  
9.5 Kg.



Urea

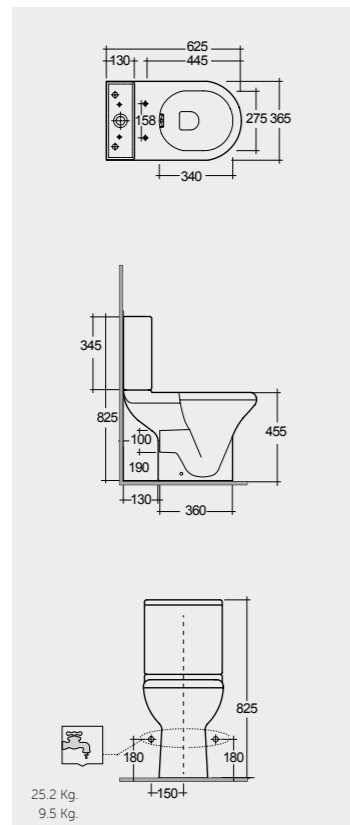

25.2 Kg.  
9.5 Kg.



Urea

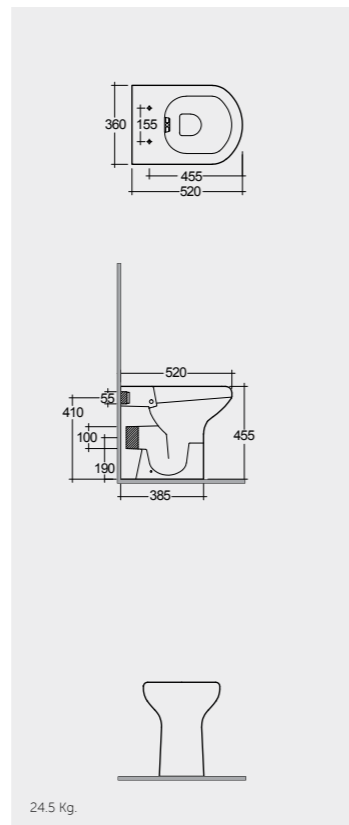

24.5 Kg.



Urea care

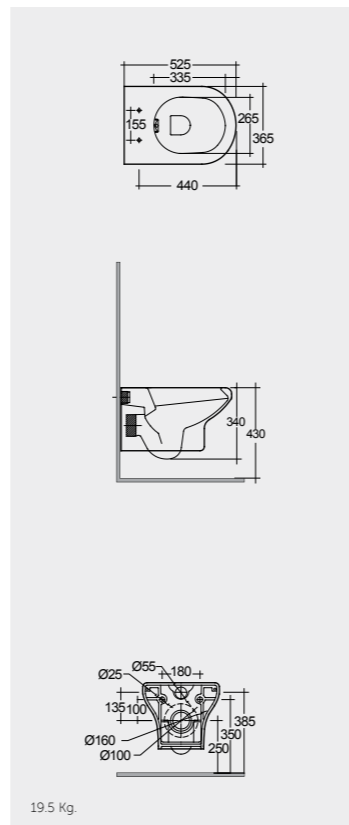

19.5 Kg.



Urea

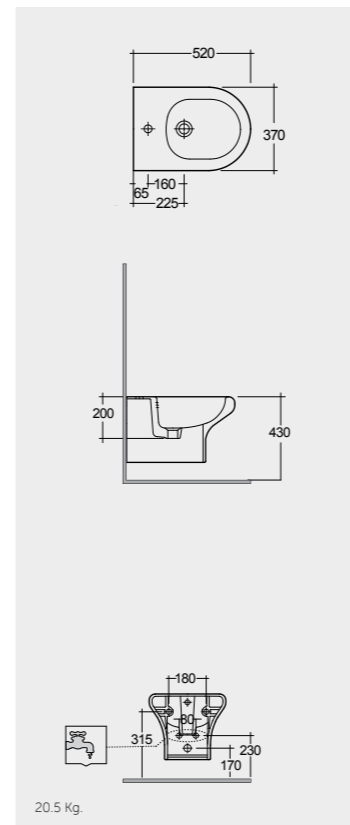

20.5 Kg.

Note | Nota | Remarque | Hinweis | Примечание

All dimensions in mm tolerance +5% for below 200mm and +3% for above 200mm | Tutte le dimensioni hanno una tolleranza di +5% mm al di sotto dei 200mm e di +3% mm al di sopra dei 200mm | Toutes les dimensions en mm tolérance +5% pour moins de 200mm et +3% pour plus de 200mm/ Alle Abmessungen in mm, Toleranz +5% für unter 200mm, und +3% für über 200mm | Все размеры указаны в мм, погрешность — +5% ниже 200 мм и +3% выше 200 мм



# SPRAY DOUCHE SET / RAK-DUO

Models | Modelli | Modèles | Modelle | Модели



SET WITH MIXER (SHATAFF)  
BRASS CHROME : SPRDOMX0001

Measurements | Misure | Dimensions |  
Abmessungen | Размеры

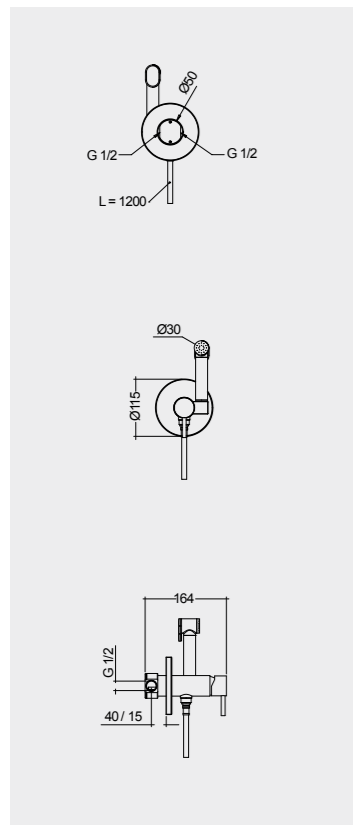

Note | Nota | Remarque | Hinweis | Примечание

All dimensions in mm tolerance +5% for below 200mm and +3% for above 200mm | Tutte le dimensioni hanno una tolleranza di +5% mm al di sotto dei 200mm e di +3% mm al di sopra dei 200mm | Toutes les dimensions en mm tolérance +5% pour moins de 200mm et +3% pour plus de 200mm/ Alle Abmessungen in mm, Toleranz +5% für unter 200mm, und +3% für über 200mm | Все размеры указаны в мм, погрешность — +5% ниже 200 мм и +3% выше 200 мм



# STAINLESS STEEL EN 1.4307 (AISI 304L)



## High Quality Material

The use of chromium nickel steel for fixtures in sanitary facilities has become today's standard for good reason. The material is robust, cost-effective and easy-care. Chromium nickel steel isn't just resistant to moisture and most acids; it also stands out due to its hardness, durability, high tolerance to heat and cold and its hygienic properties. Dirt and grease can be easily washed from smooth, pore-free surface.

### BENEFITS:

- Stainless and resistant to all commonly available acids used in the home
- Hygienic and easy to clean even when extremely dirty
- Neutral in colour and timelessly beautiful
- Impact-resistant, tear-proof, heat and fire-proof
- Easy to repair and completely recyclable

## Mobility aids

Grab rails are now very common in well laid out bathrooms. Rak-Silver grab rails made of easy-to grab stainless steel have now started to make bath time and the use of toilet facilities easier for everyone.

### MAIN FEATURES:

- Inspected and certified products (TUV/LGA).
- Ergonomical diameter of 32mm and thickness of 1.2mm
- Cover rosettes in chromium nickel steel with concealed mounting.
- Mounting plates attached in an easy-to install way
- Long service life

*Mounting only suitable for concrete masonry.*

## Materiale di alta qualità

L'utilizzo di acciaio al nichel cromo a fini igienico-sanitari è diventato oggi uno standard per ovvi motivi. Il materiale è robusto, economico e di facile manutenzione. L'acciaio al nichel cromo non è solo resistente all'umidità e alla maggior parte degli acidi; si distingue anche per la sua durezza, durata, alta tolleranza al calore e al freddo e alle sue proprietà igieniche. Sporizia e grasso possono essere facilmente eliminati dalla sua superficie liscia e priva di pori.

### VANTAGGI:

- Inossidabile e resistente a tutti gli acidi di uso comune in casa
- Igienico e facile da pulire anche se estremamente sporco
- Di colore neutro e di una bellezza senza tempo
- Resistente agli urti, resistente agli strappi, al calore e al fuoco
- Facile da riparare e completamente riciclabile

## Un valido supporto alla mobilità

I maniglioni sono molto comuni nei bagni ben strutturati. I maniglioni Rak-Silver in acciaio inossidabile facili da afferrare, rendono più semplice ed agevole l'uso dei servizi igienici per tutti.

### CARATTERISTICHE PRINCIPALI:

- Prodotti controllati e certificati (TUV/LGA)
- Diametro ergonomico di 32 mm e spessore di 1,2 mm
- Rosette in acciaio al nichel cromo con fissaggio nascosto
- Piastre di montaggio facili da installare
- Lunga durata

*Montaggio adatto solo per muratura in calcestruzzo.*

## Matériel de haute qualité

L'usage de l'acier au nickel chromé (NiCr) aux fins hygiéniques-sanitaires, est devenu, aujourd'hui, un standard pour des motifs évidents. Le matériel est robuste, économique et facile à maintenir. L'acier au nickel chromé (NiCr) n'est pas seulement résistant à l'humidité et à la majeure partie des acides; il se distingue également par sa dureté, sa durée, sa haute tolérance à la chaleur et au froid, ainsi que par ses propriétés hygiéniques. Les saletés et le gras peuvent être facilement éliminés de sa superficie lisse et sans pores.

### Avantages :

- Inoxydable et résistant à tous les acides communs utilisés à la maison
- Hygiénique et facile à nettoyer même en cas de grande saleté
- De couleur neutre et d'une beauté sans âge
- Résistant aux coups, aux fissures, à la chaleur et au feu
- Facile à réparer et complètement recyclable.

## Un support précieux à la mobilité

Les poignées sont bien communes dans les salles de bains bien structurées. Les poignées Rak-Silver en acier inoxydable, faciles à saisir, rendent l'usage des services hygiéniques plus facile et plus agréables pour tout le monde.

### CARACTÉRISTIQUES PRINCIPALES:

- Produits contrôlés et certifiés (TUVILGA)
- Diamètre ergonomique de 32 mm et épaisseur de 1,2 mm.
- Rosettes en acier au nickel chromé (NiCr) avec fixations cachées
- Carreaux à monter, faciles à installer
- Longue durée

*Montage adapté seulement aux murs en béton*

## Hochqualitatives Material

Die Verwendung von NiCr zu hygienisch-sanitären Zwecken ist heute, aus offensichtlichen Gründen, zu einem Standard geworden. Das Material ist robust, ökonomisch und leicht instandzuhalten. NiCr ist nicht nur resistent gegen Feuchte und die meisten Säuren, sondern zeichnet sich durch seine Härte, Dauer, seine Hitze- und Frostbeständigkeit, sowie durch seine hygienischen Eigenschaften aus. Schmutz und Fett können von seiner glatten und porenfreien Oberfläche leicht entfernt werden.

### Vorteile:

- Rostfrei und resistent gegen alle im Haus gebräuchlichen Säuren.
- Hygienisch und leicht zu reinigen, selbst beim extremen Schmutz
- In neutraler Farbe und von zeitloser Schönheit
- Stoß- und rissfest, wärme- und feuerbeständig
- Leicht zu reparieren und vollkommen wiederverwertbar

## Eine wertvolle Unterstützung für die Mobilität

Die Griffe sind in allen gut strukturierten Bädern gebräuchlich. Die gut greifbaren Griffe Rak-Silver in Edelstahl, gestalten den Gebrauch der hygienischen Dienste für alle einfacher und angenehmer.

### HAUPT-EIGENSCHAFTEN:

- Kontrollierte und zertifizierte Produkte (TUVILGA)
- Ergonomischer Durchmesser von 32 mm und Dicke 1,2 mm
- Rosetten aus NiCr mit verdeckten Befestigungen
- Leicht zu installierende Montageplatten
- Langlebige Platten

*Montage nur an Betonwänden.*

## Высококачественный материал

Использование деталей из хромоникелевой стали в сантехнических изделий стало современным стандартом неспроста. Это недорогой и прочный материал, не требующий особого ухода.

Хромоникелевая сталь не только устойчива к влаге и большинству кислот; она также отличается своей твердостью, долговечностью, высокой устойчивостью к нагреву и охлаждению, а также своими гигиеническими свойствами. С гладкой поверхности этого материала можно легко смыть грязь и жир.

### ПРЕИМУЩЕСТВА :

- Нержавеющая и устойчивая ко всем общедоступным кислотам, используемым в домашних условиях
- Гигиенично и легко чистится даже при сильном загрязнении
- Нейтральная по цвету и всегда красивая
- Ударопрочная, прочная на разрыв, жаро- и огнестойкая
- Легко ремонтируется и полностью перерабатывается

## Помощь в мобильности

В хорошо продуманных ванных комнатах стало нормой использование поручней. Поручни RAK-Silver, сделанные из нержавеющей стали, сделали принятие ванны и использование туалета лёгким для всех.

### ОСНОВНЫЕ ОСОБЕННОСТИ::

- Проверенный и сертифицированный продукт (TUV/LGA)
- Эргономичные диаметр 32 мм и толщина 1,2 мм
- Накладки розеток из хромоникелевой стали со скрытым монтажом
- Монтажные панели легко устанавливать
- Длительный срок службы

*Возможно монтировать только на бетонные стены.*





# GRAB BARS

Models | Modelli | Modèles | Modelle | Модели

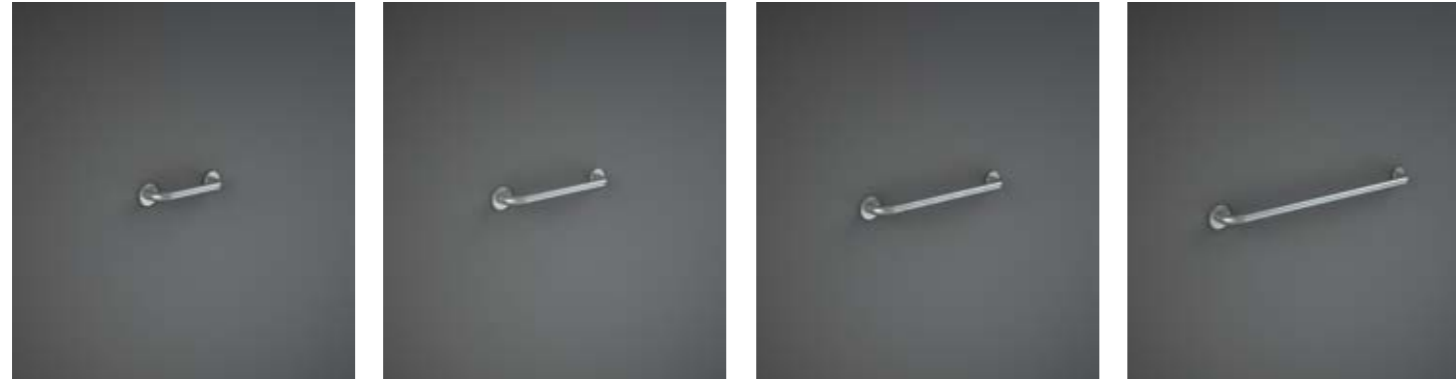

300mm (32mm DIA.)  
SILGBR00300

450mm (32mm DIA.)  
SILGBR00450

600mm (32mm DIA.)  
SILGBR00600

900mm (32mm DIA.)  
SILGBR00900

Measurements | Misure | Dimensions | Abmessungen | Размеры

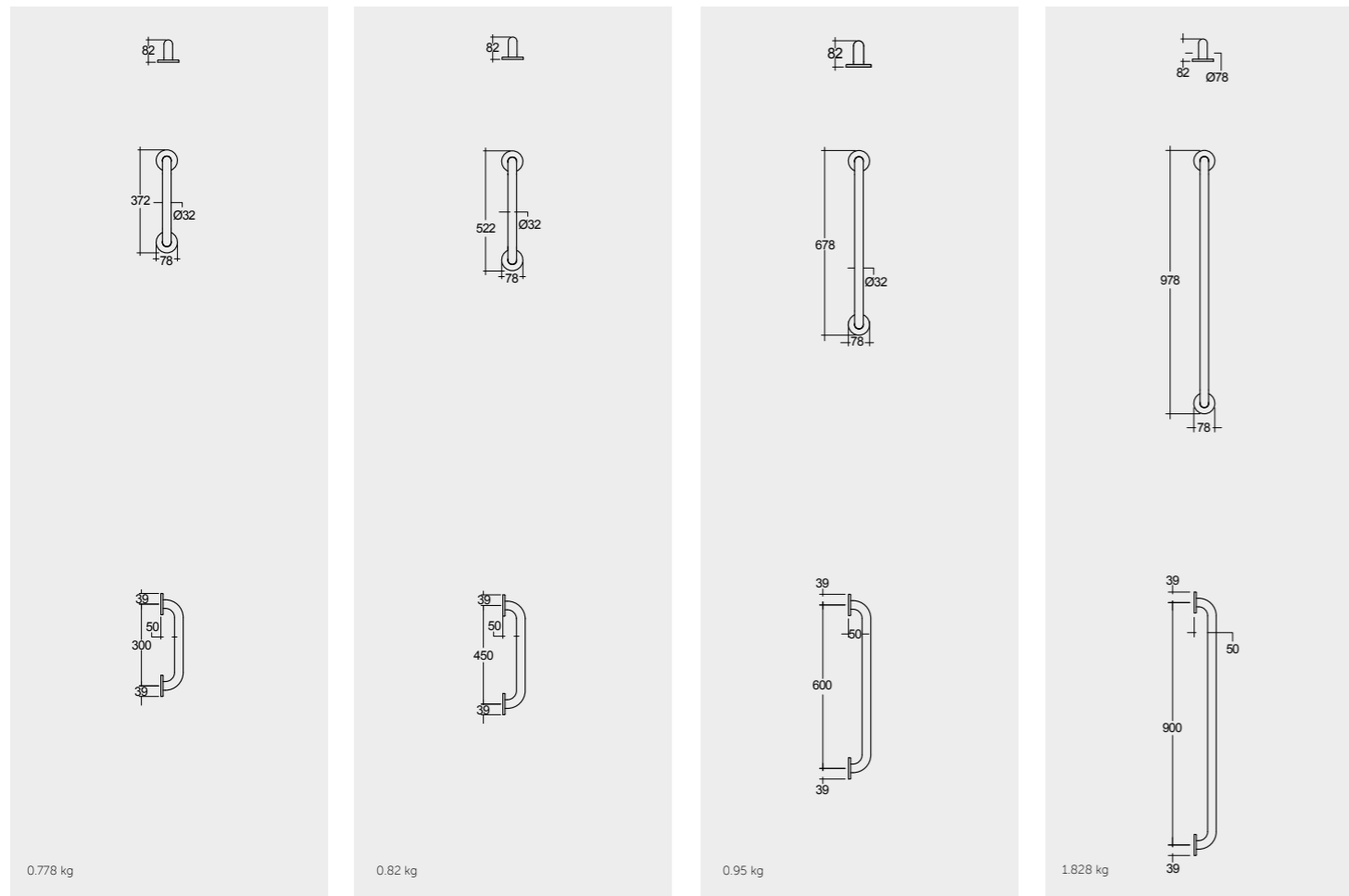

Note | Nota | Remarque | Hinweis | Примечание

All dimensions in mm tolerance +5% for below 200mm and +3% for above 200mm | Tutte le dimensioni hanno una tolleranza di +5% mm al di sotto dei 200mm e di +3% mm al di sopra dei 200mm | Toutes les dimensions en mm tolérance +5% pour moins de 200mm et +3% pour plus de 200mm/ Alle Abmessungen in mm, Toleranz +5% für unter 200mm, und +3% für über 200mm | Все размеры указаны в мм, погрешность — +5% ниже 200 мм и +3% выше 200 мм

Models | Modelli | Modèles | Modelle | Модели



1200mm (32mm DIA.)  
SILGBR01200

135° Angle (32mm DIA.)  
SILGBR135LR

90° Angle (32mm DIA.)  
SILGBR090LR

850mm (32mm DIA.)  
SILGBRPH001

Foldable, with paper roll holder

Measurements | Misure | Dimensions | Abmessungen | Размеры

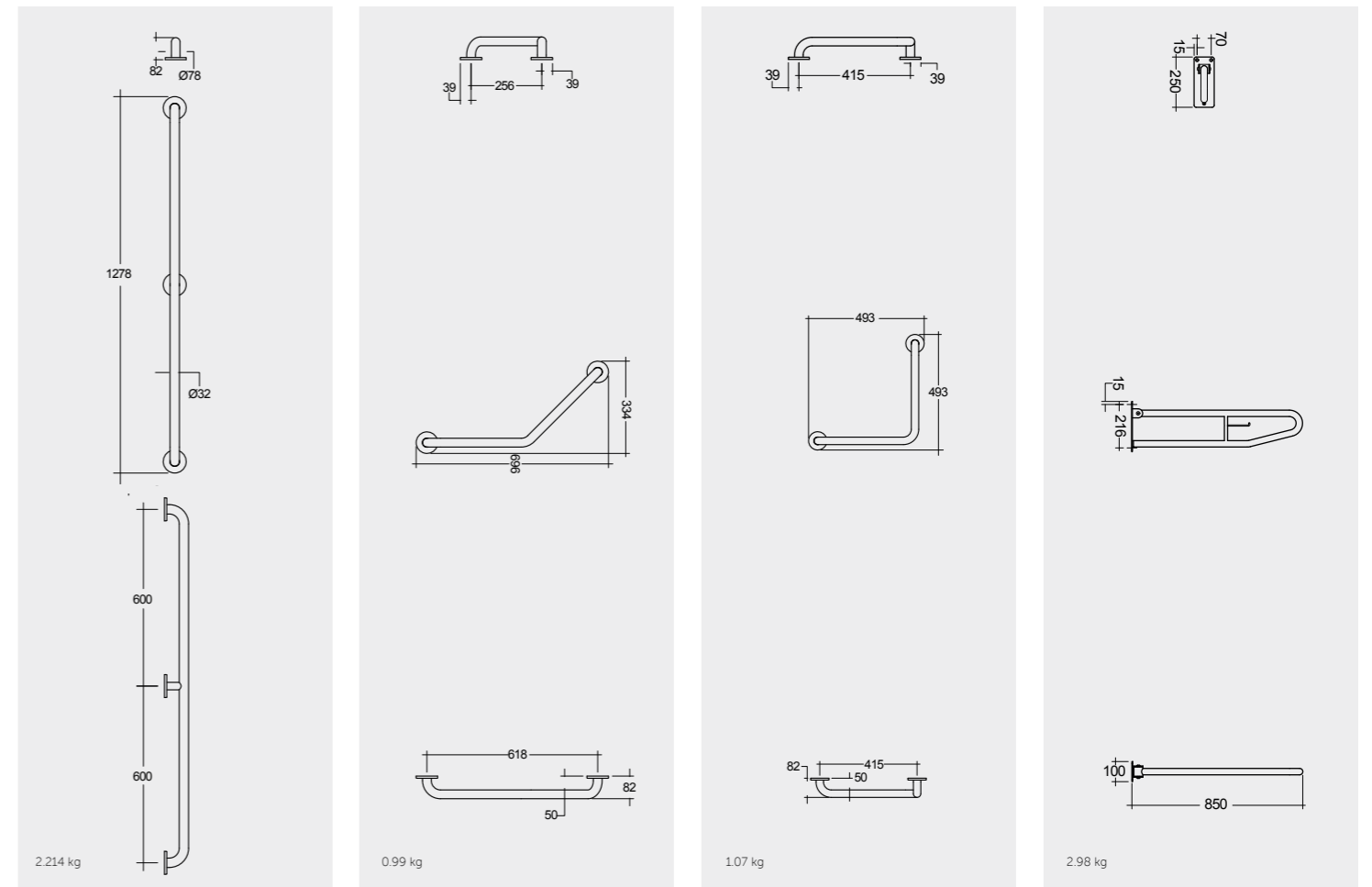

Models | Modelli | Modèles | Modelle | Модели



90° Angle BIG RIGHT (32mm DIA.) SILGBR090BR    90° Angle BIG LEFT (32mm DIA.) SILGBR090BL    90° Angle BIG RIGHT (32mm DIA.) SILGBR090SR    90° Angle BIG LEFT (32mm DIA.) SILGBR090SL

Measurements | Misure | Dimensions | Abmessungen | Размеры

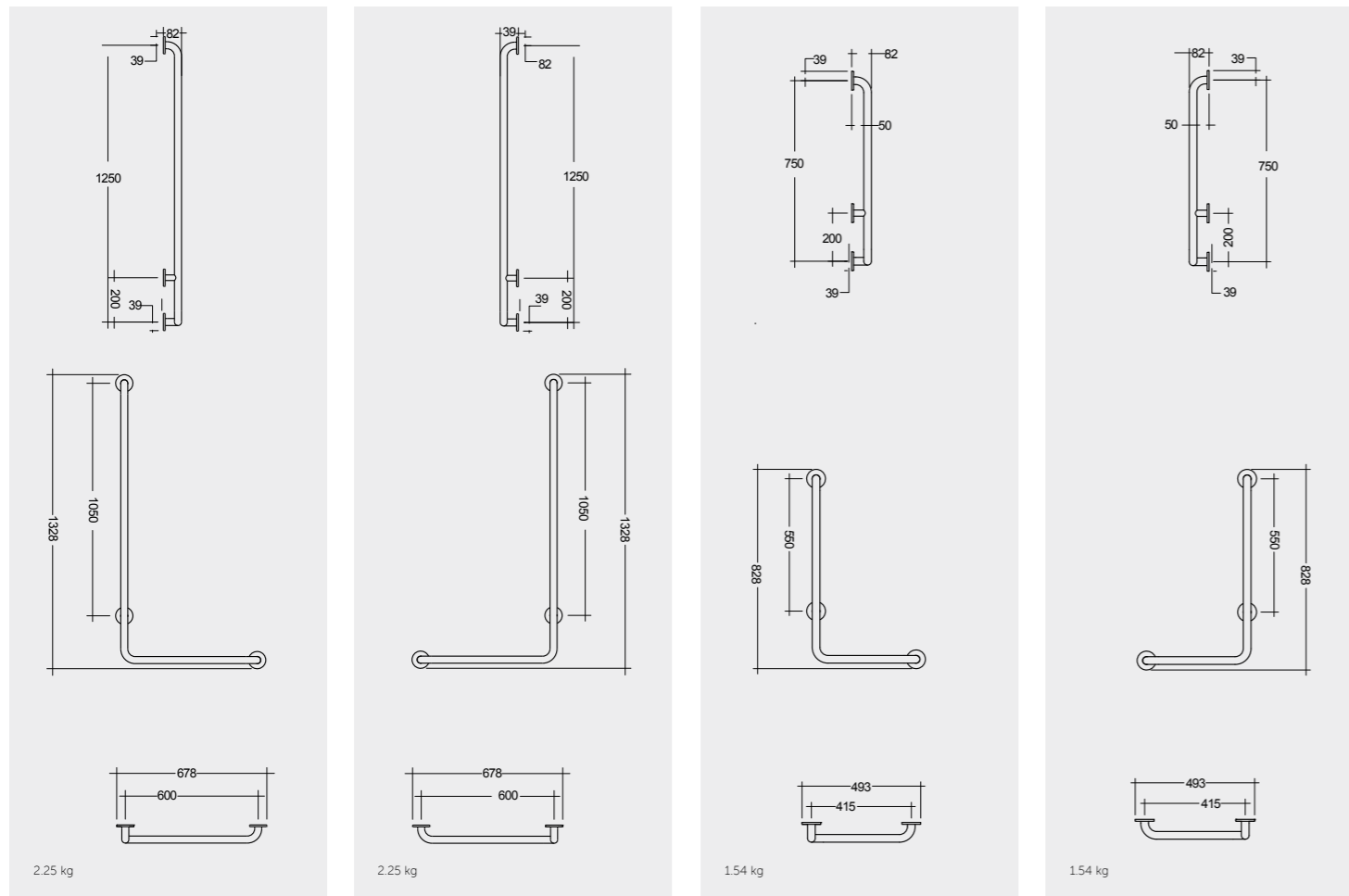

Note | Nota | Remarque | Hinweis | Примечание

All dimensions in mm tolerance +5% for below 200mm and +3% for above 200mm | Tutte le dimensioni hanno una tolleranza di +5% mm al di sotto dei 200mm e di +3% mm al di sopra dei 200mm | Toutes les dimensions en mm tolérance +5% pour moins de 200mm et +3% pour plus de 200mm/ Alle Abmessungen in mm, Toleranz +5% für unter 200mm, und +3% für über 200mm | Все размеры указаны в мм, погрешность — +5% ниже 200 мм и +3% выше 200 мм

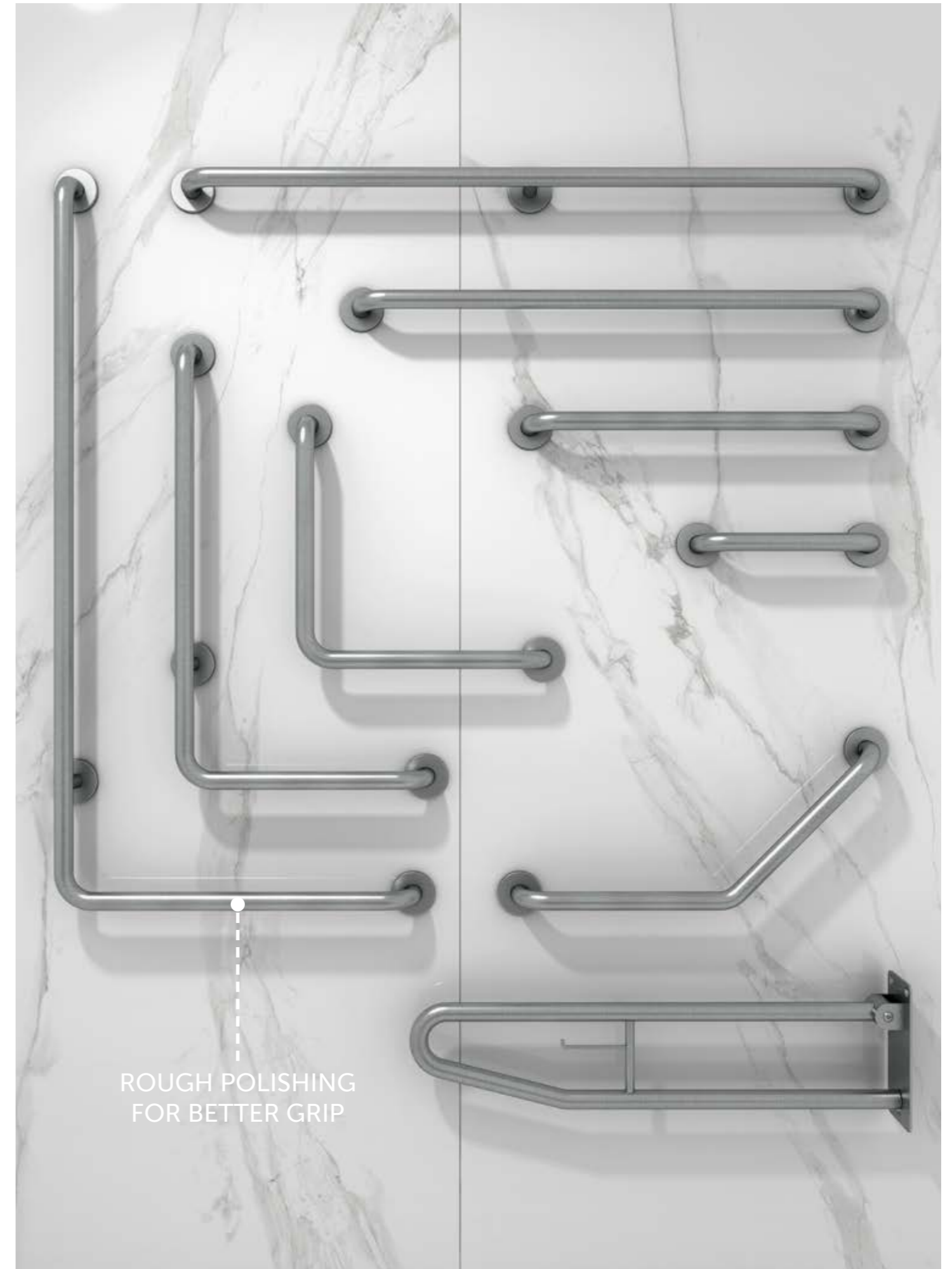

ROUGH POLISHING  
FOR BETTER GRIP

# SHOWER SEATS & ACCESSORIES

Models | Modelli | Modèles | Modelle | Модели



SHOWER SEAT (Matt White)  
SILFST00031



SHOWER STOOL (Matt White)  
SILSST00041



ROBE HANGER & GLASS WIPE (Matt White)  
SILRHR00051

Foldable

Measurements | Misure | Dimensions | Abmessungen | Размеры

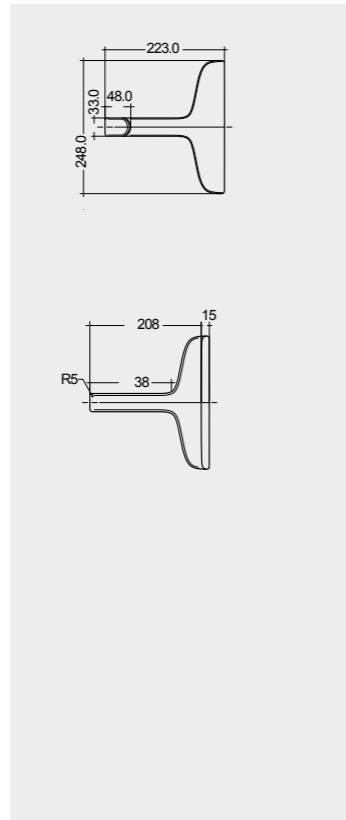
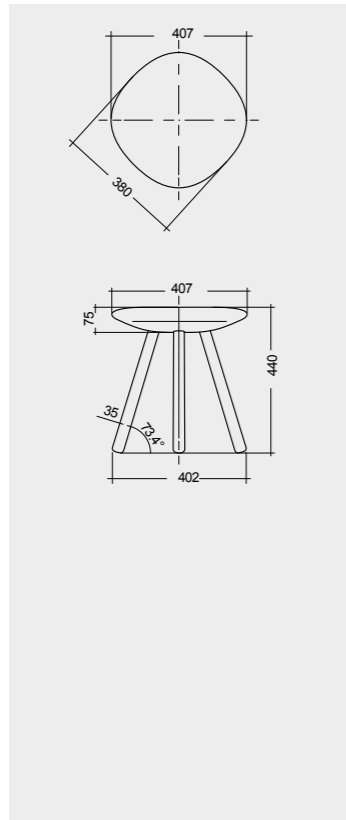
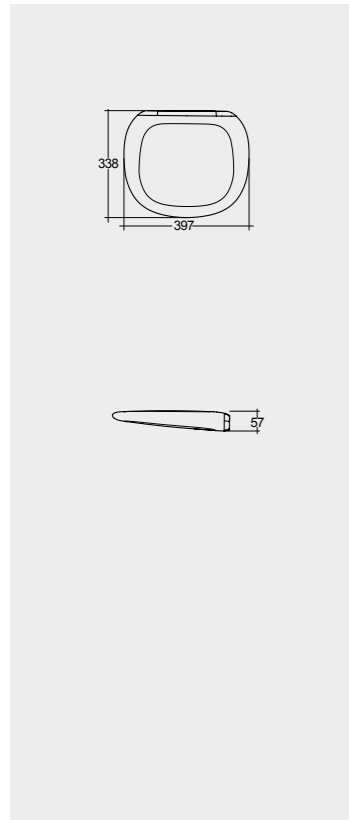

Note | Nota | Remarque | Hinweis | Примечание

All dimensions in mm tolerance +5% for below 200mm and +3% for above 200mm | Tutte le dimensioni hanno una tolleranza di +5% mm al di sotto dei 200mm e di +3% mm al di sopra dei 200mm | Toutes les dimensions en mm tolérance +5% pour moins de 200mm et +3% pour plus de 200mm/ Alle Abmessungen in mm, Toleranz +5% für unter 200mm, und +3% für über 200mm | Все размеры указаны в мм, погрешность — +5% ниже 200 мм и +3% выше 200 мм





## SAFE AND ELEGANT SOLUTION: BARRIER FREE (WALK IN) SHOWER TRAYS

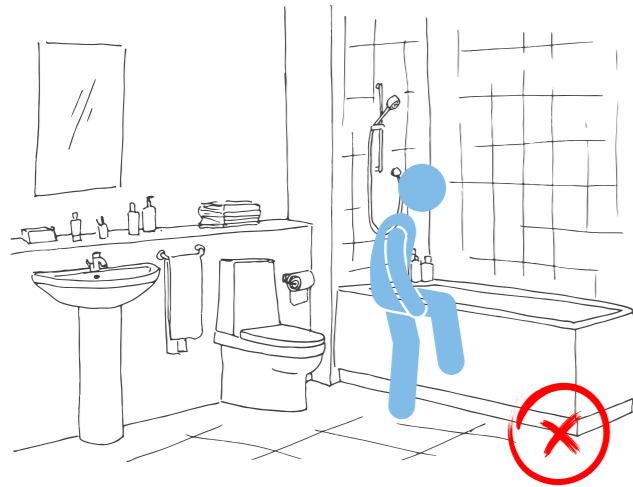

SAFE AND VERY BEAUTIFUL DESIGN

### BATHTUB REPLACEMENT VERSIONS

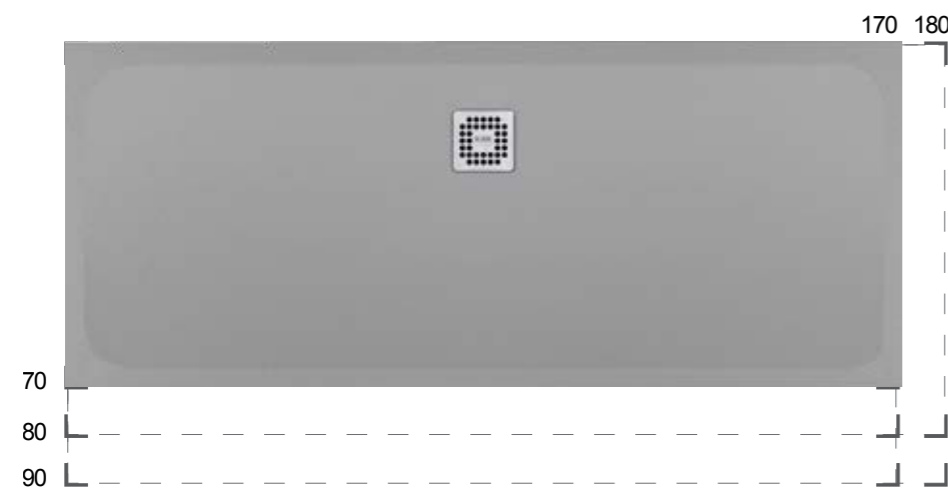

### COLORS AND FINISHES

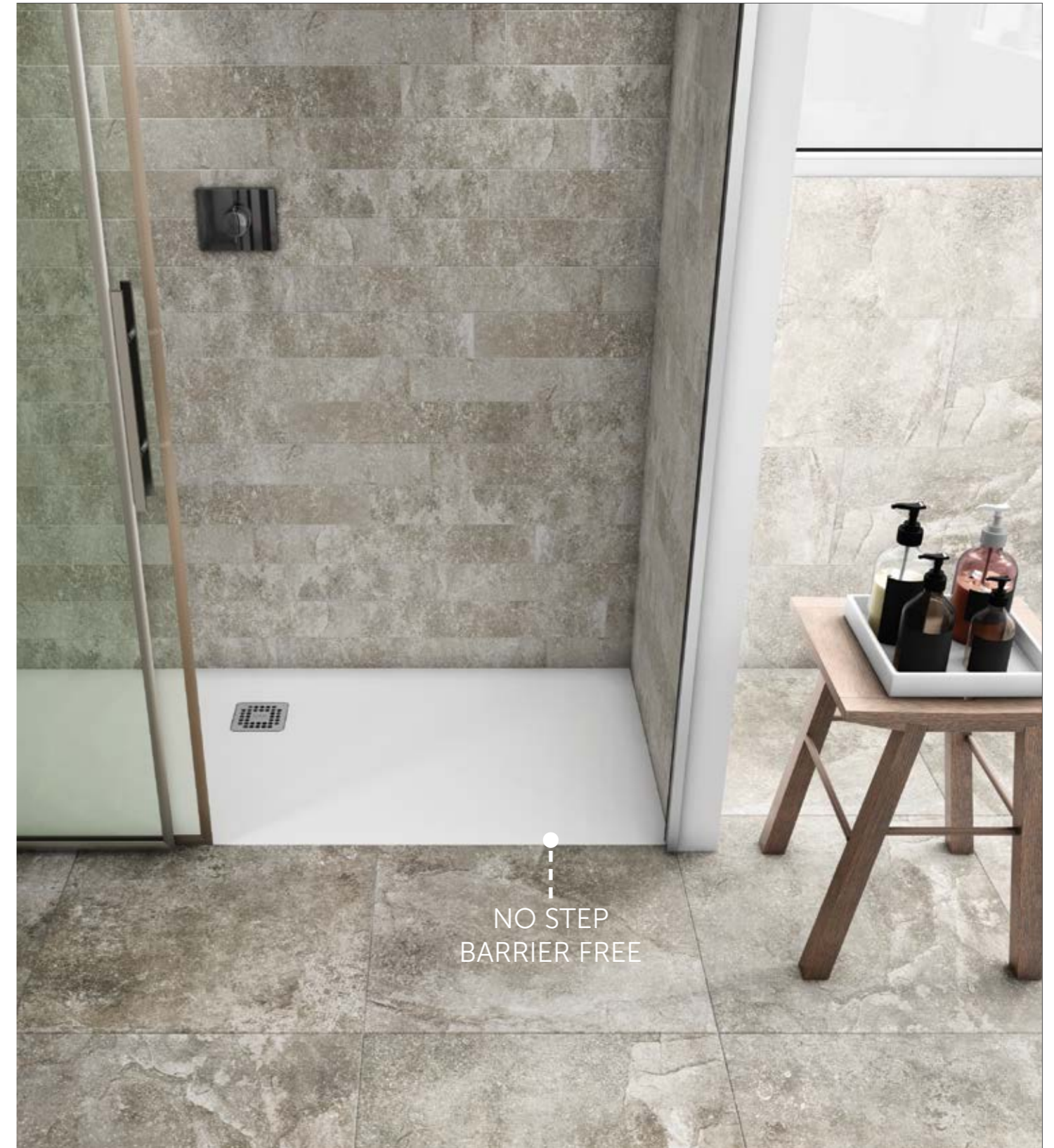

**RFBR080180S500**  
80X180 CM (Bathtub replacement) White (500)

Models | Modelli | Modèles | Modelle | Модели



90 X 180 CM  
RFB090180S500

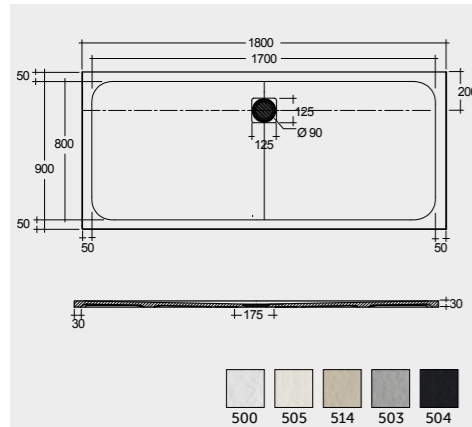

90 X 170 CM  
RFB090170S500

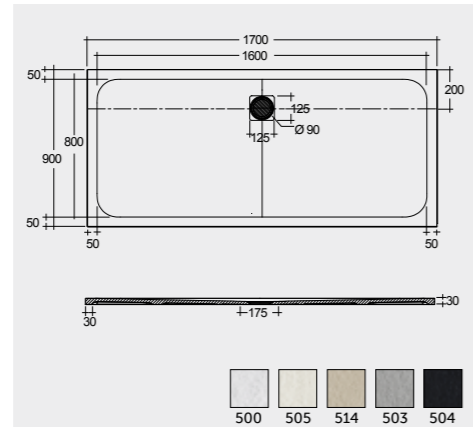

80 X 180 CM  
RFB080180S500

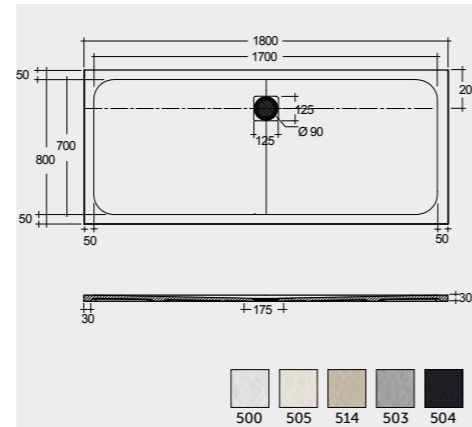

Models | Modelli | Modèles | Modelle | Модели



80 X 170 CM  
RFB080170S500

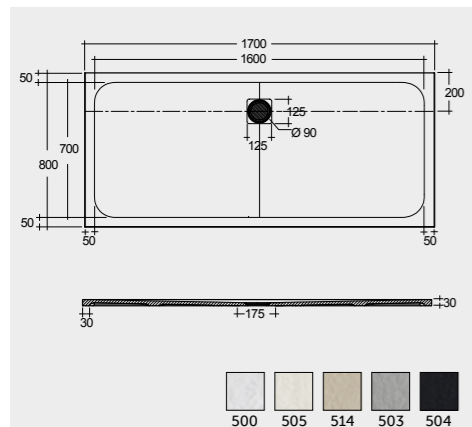

70 X 170 CM  
RFB070170S500

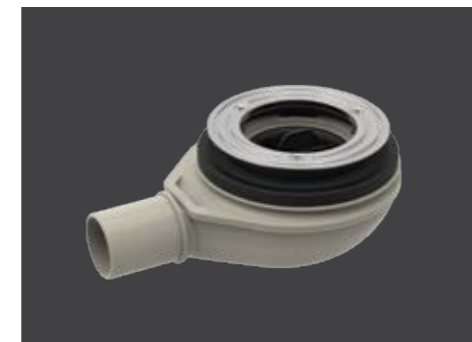
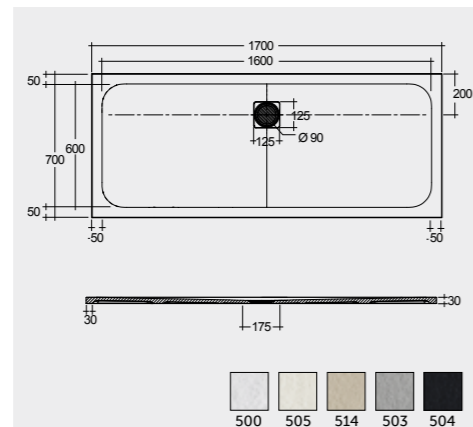

SHOWER DRAIN DEPTH OF WATER SEAL 30MM  
RFXGW00001

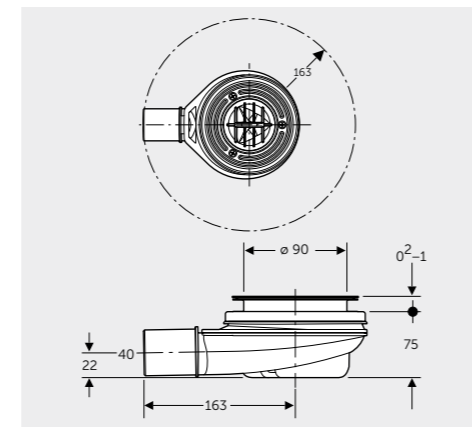







POWERFUL  
LIGHT

INTERNAL  
LIGHT

PLENTY OF  
STORAGE  
SPACE

-  W 80 x D 46 x H 60CM
-  W 30 x D 23 x H 120CM
-  W 80 x D 18 x H 68CM
- 

Modets | Modelli | Modèles | Modelle | Модели



W 40 x D 18 x H 68CM  
JOYMC04001



W 60 x D 18 x H 68CM  
JOYMC06002



W 80 x D 18 x H 68CM  
JOYMC08002

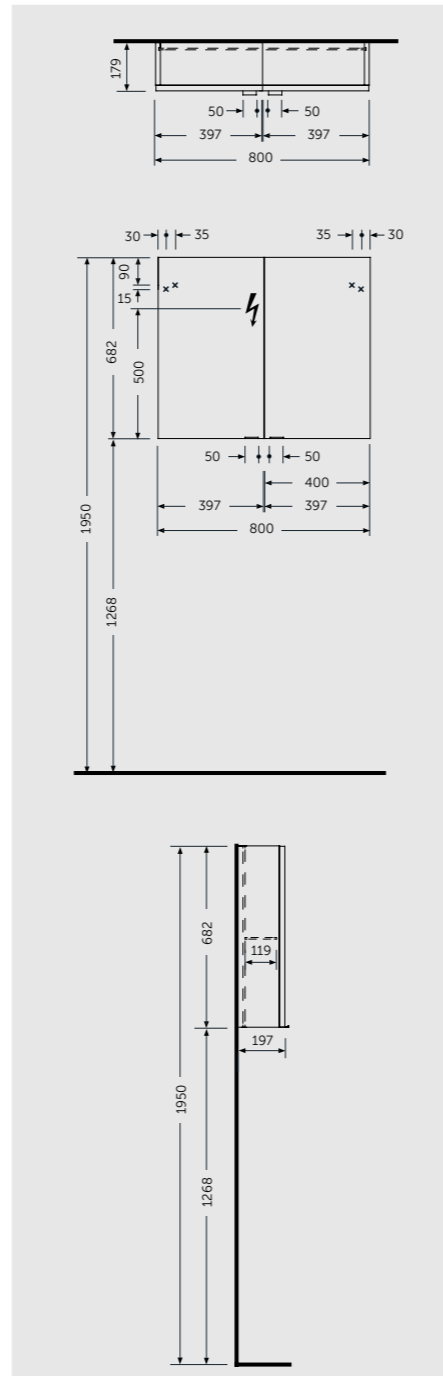
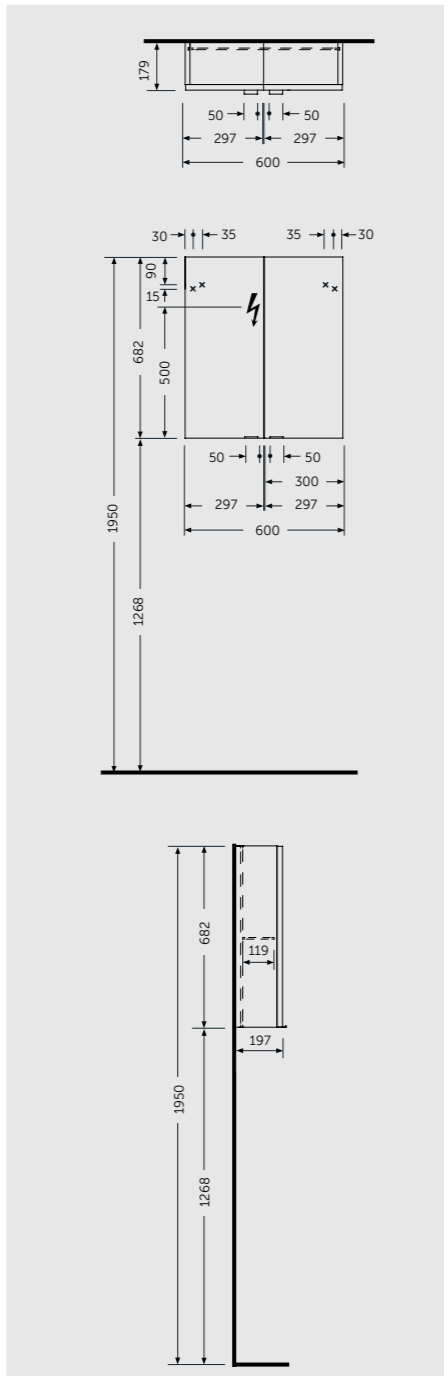
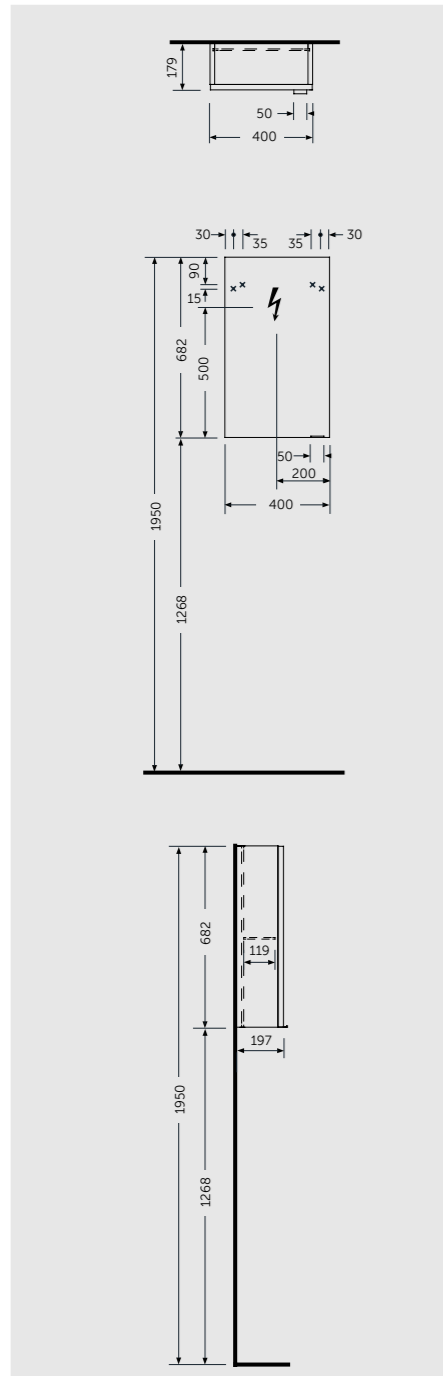

Modets | Modelli | Modèles | Modelle | Модели



W 100 x D 18 x H 68CM  
JOYMC10003



120CM = 2x W 60 x D 18 x H 68CM Cabinets  
JOYMC06002 x2

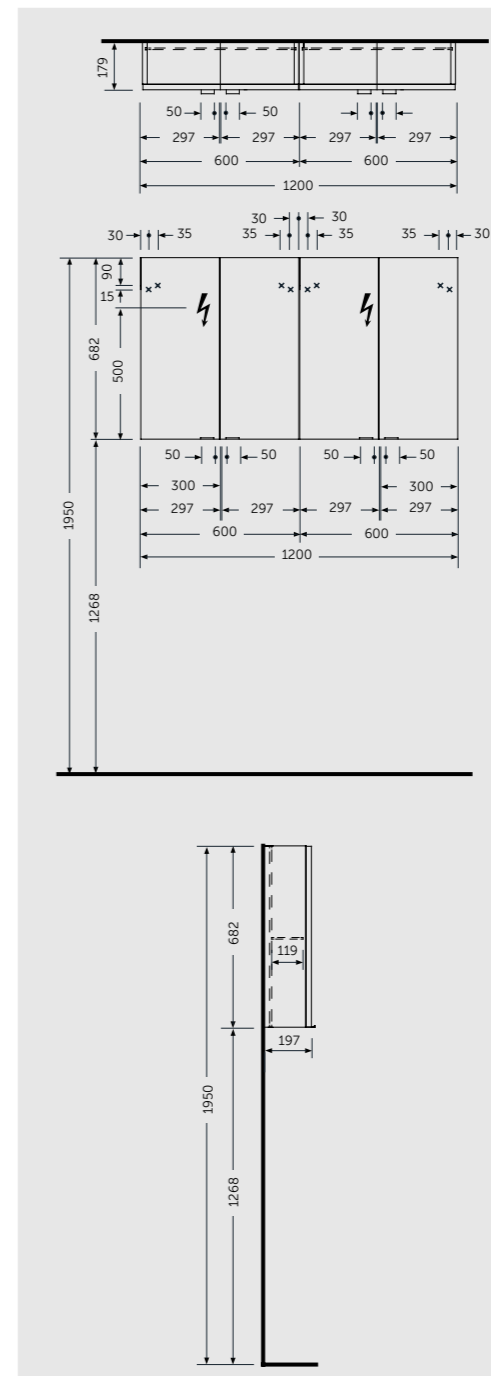
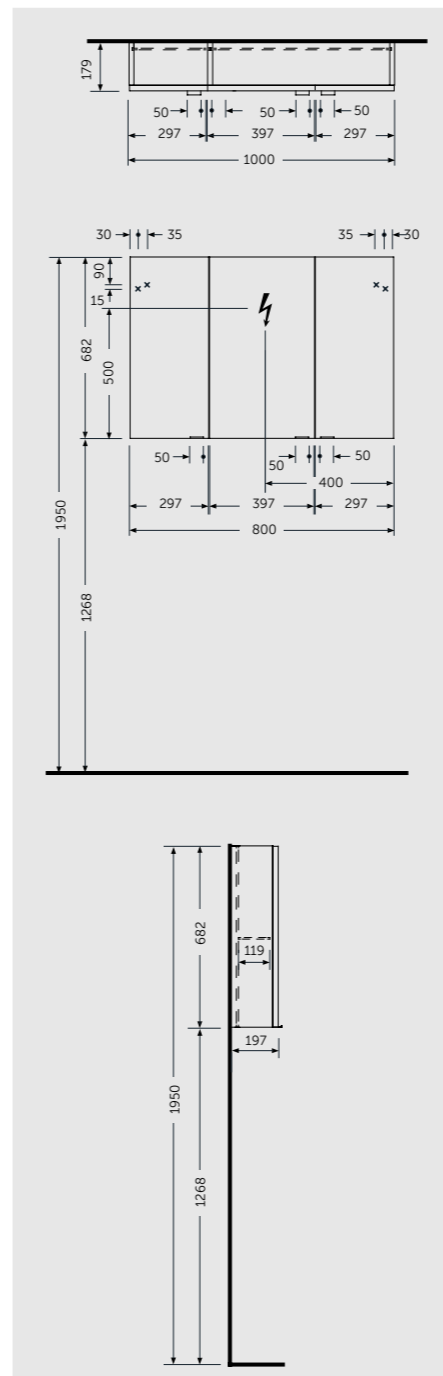

**TOP MOUNTED T-BAR LIGHT**  
Luce "a T" montabile in alto  
Spot en t-bar montée sur le dessus  
T-bar Aufsatzlicht



JOYTB6000CR  
Cool White 6000K  
450 Lumens

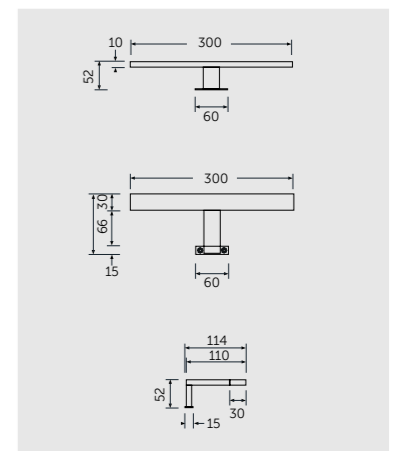

**USB RECHARGABLE LIGHT**  
Luce ricaricabile del USB  
Lumière USB rechargeable  
USB rechargeable Licht



JOYUSBRCCR  
Neutral White 4000K  
150 Lumens

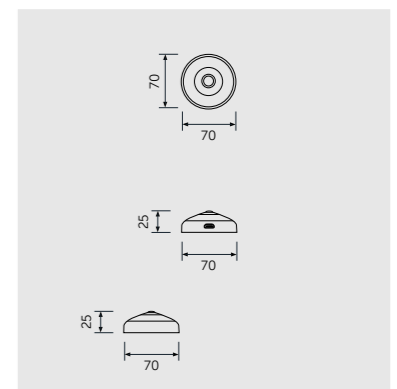



Modets | Modelli | Modèles | Modelle | Модели



W 40 x D 22 x H 60CM  
JOYWH040PWH



W 60 x D 46 x H 60CM  
JOYWH060PWH



W 80 x D 46 x H 60CM  
JOYWH080PWH

Modets | Modelli | Modèles | Modelle | Модели



W 100 x D 46 x H 60CM  
JOYWH100PWH



W 30 x D 23 x H 120CM  
JOYTS120PWH

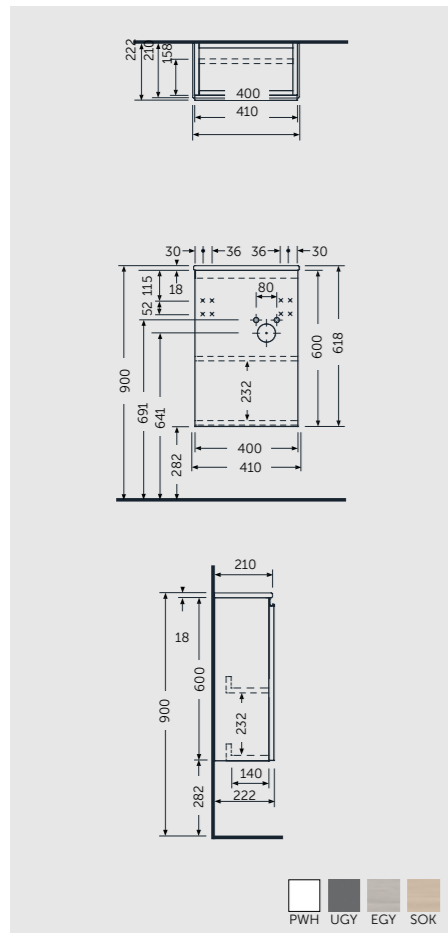

PWH UGY EGY SOK

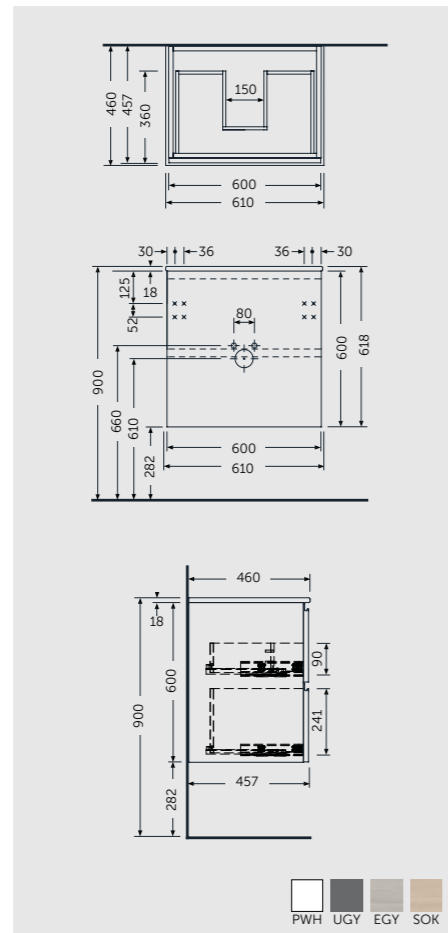

PWH UGY EGY SOK

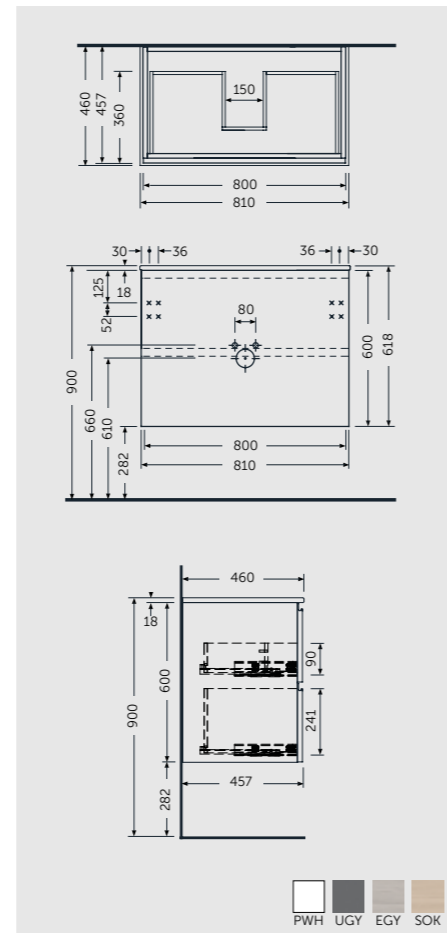

PWH UGY EGY SOK

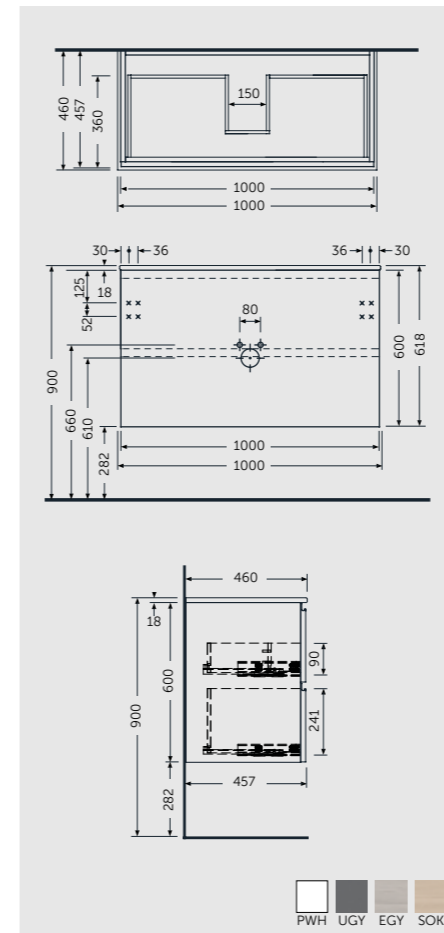

PWH UGY EGY SOK

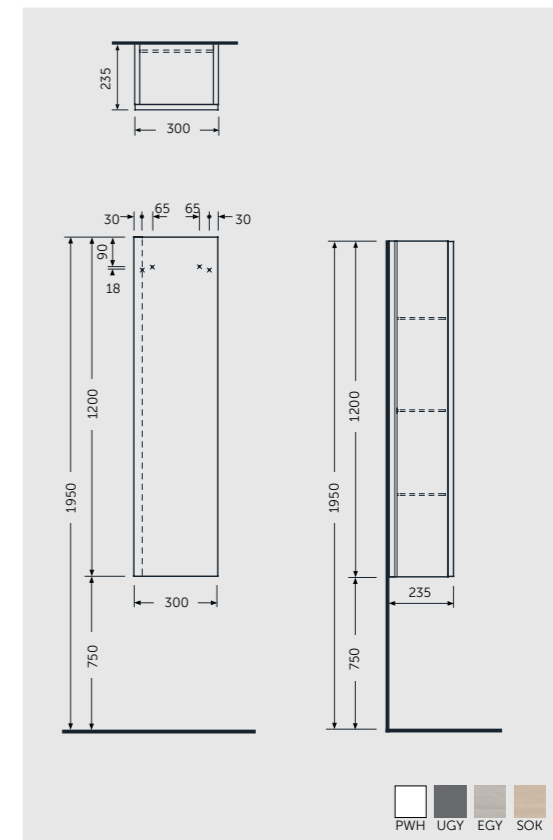

PWH UGY EGY SOK



120cm = 2x W 60CM Units  
JOYWH060PWH x2

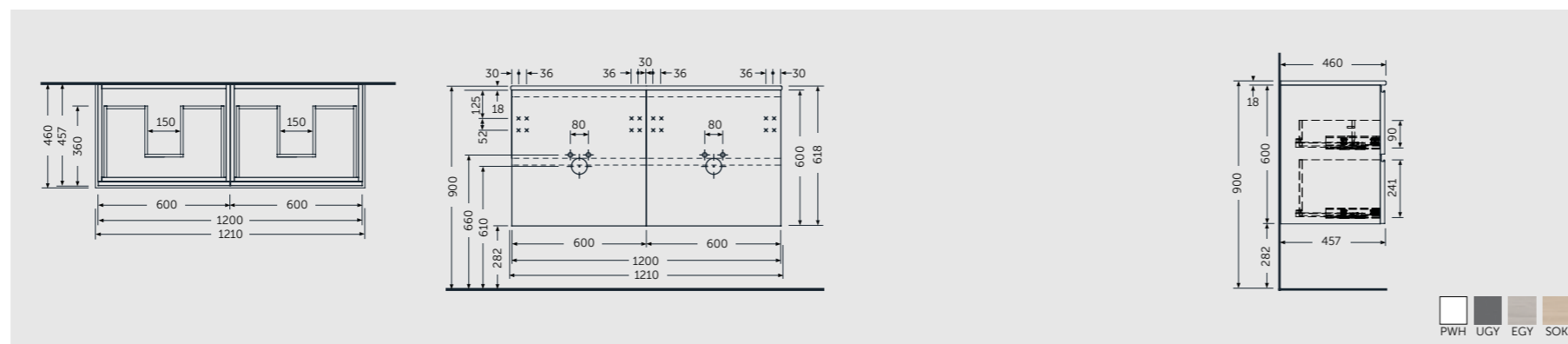

PWH UGY EGY SOK

# WASH BASINS / RAK-JOY

Models | Modelli | Modèles | Modelle | Модели



41 x 22CM  
JOYWB4106AWHA



61 x 46CM  
JOYDI06101WH



81 x 46CM  
JOYDI08101WH

Measurements | Misure | Dimensions | Abmessungen | Размеры

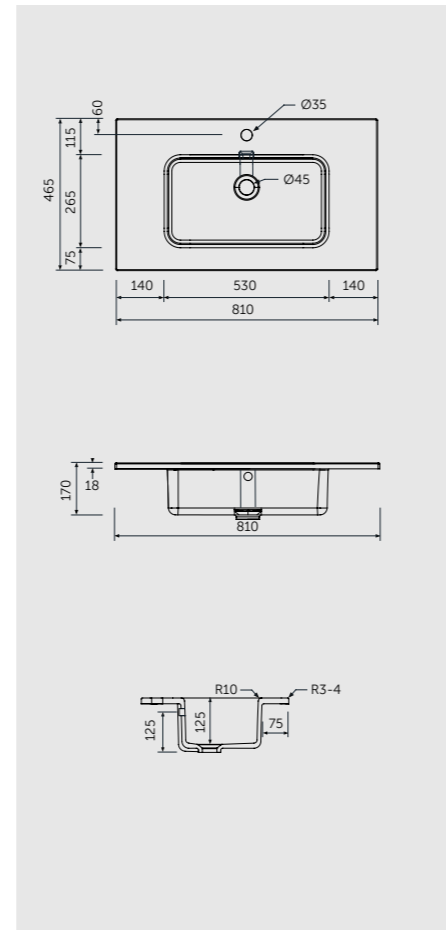
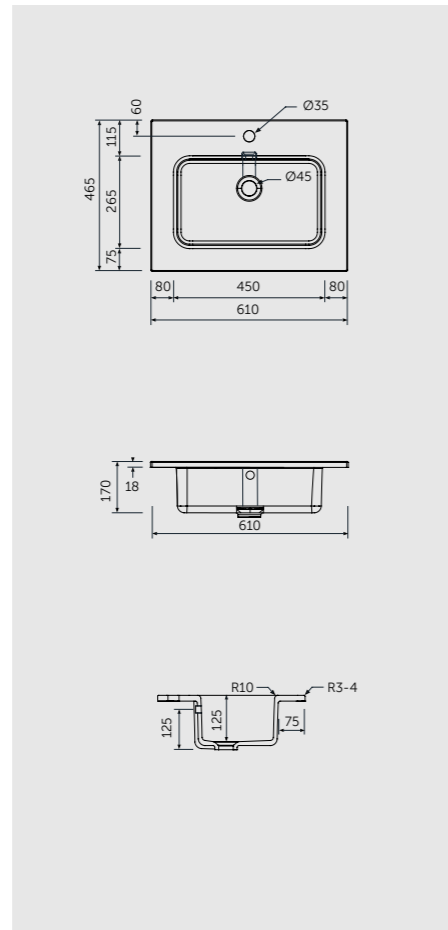
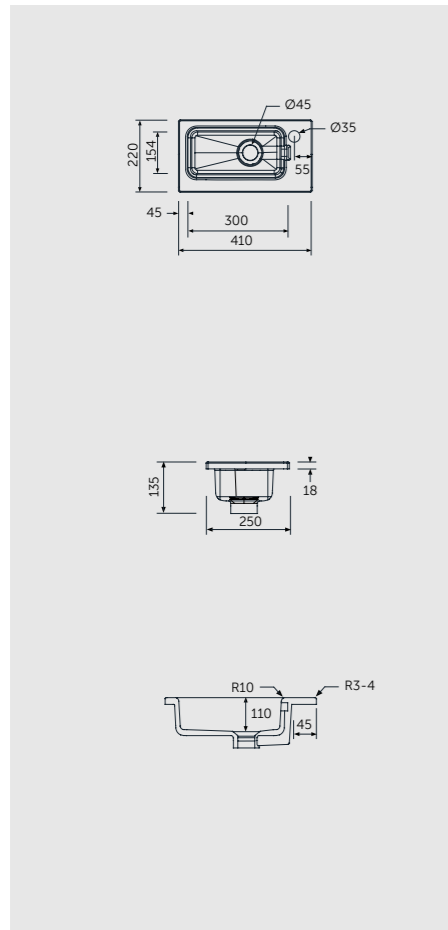

Models | Modelli | Modèles | Modelle | Модели



101 x 46CM  
JOYDI10101WH



121 x 46CM  
JOYDI12102WH

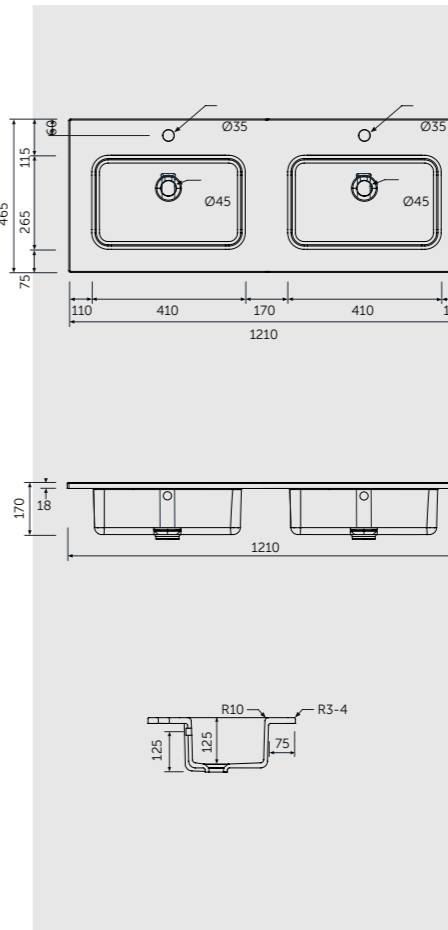
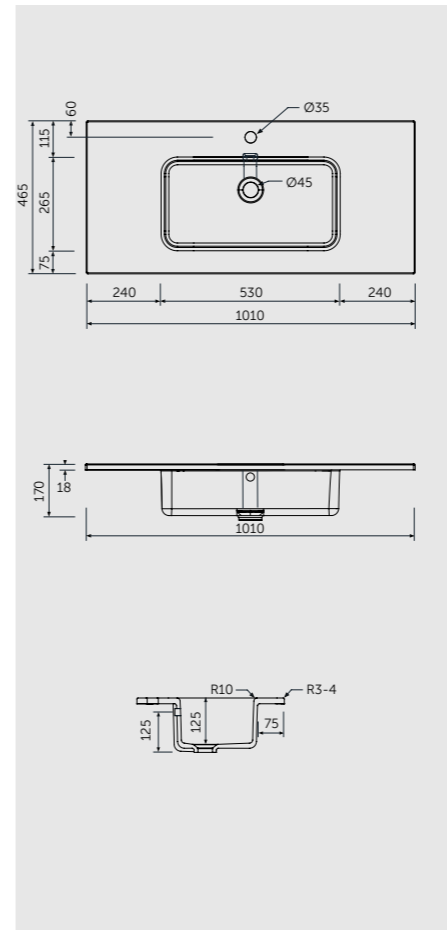

Note | Nota | Remarque | Hinweis | Примечание

All dimensions in mm tolerance +5% for below 200mm and +3% for above 200mm | Tutte le dimensioni hanno una tolleranza di +5% mm al di sotto dei 200mm e di +3% mm al di sopra dei 200mm | Toutes les dimensions en mm tolérance +5% pour moins de 200mm et +3% pour plus de 200mm/ Alle Abmessungen in mm, Toleranz +5% für unter 200mm, und +3% für über 200mm | Все размеры указаны в мм, погрешность — +5% ниже 200 мм и +3% выше 200 мм

RAK CERAMICS  
P.O. Box 4714, Ras Al Khaimah,  
United Arab Emirates (U.A.E.)  
Tel.: +971 7 2467000  
Fax: +971 7 2445270  
Email : info@rakceramics.com

---

**RAKCERAMICS.COM**

---



[RAKCERAMICS.COM](http://RAKCERAMICS.COM)

**RAK**  
CERAMICS